

Stall 3 x 2 m. (element roof)

Assembly instruction

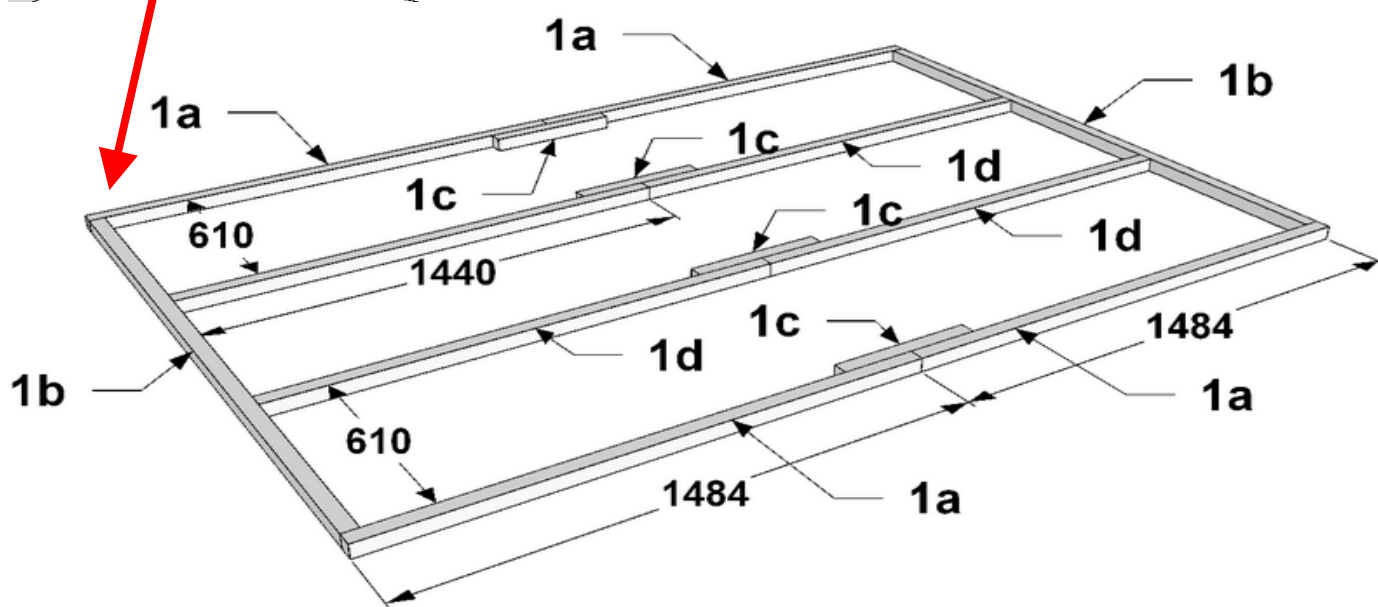
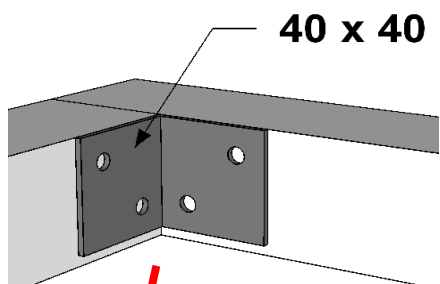

1a/d	+	1a/d	(1c)	4,5 x 80	16
-------------	---	-------------	------	-----------------	-----------

1b	+	1a	+	1d
-----------	---	-----------	---	-----------

40 x 40 x 40	8
3,5 x 40	48

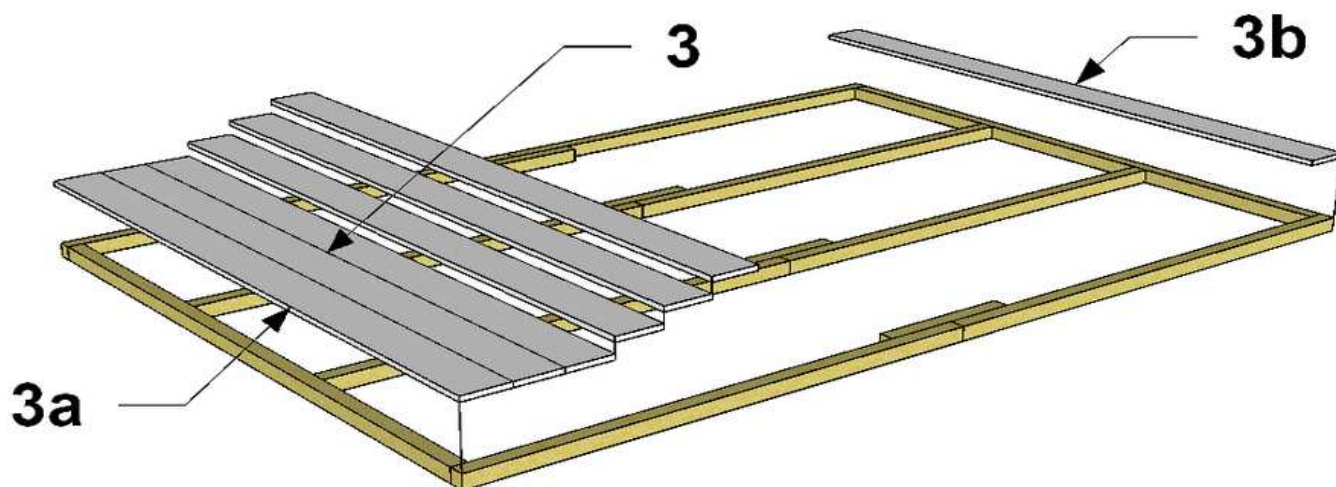

3a	+	3	+	3b	2,5 x 50	100
-----------	---	----------	---	-----------	-----------------	------------

Stall 3 x 2 m. (element roof)

Assembly instruction

2/9

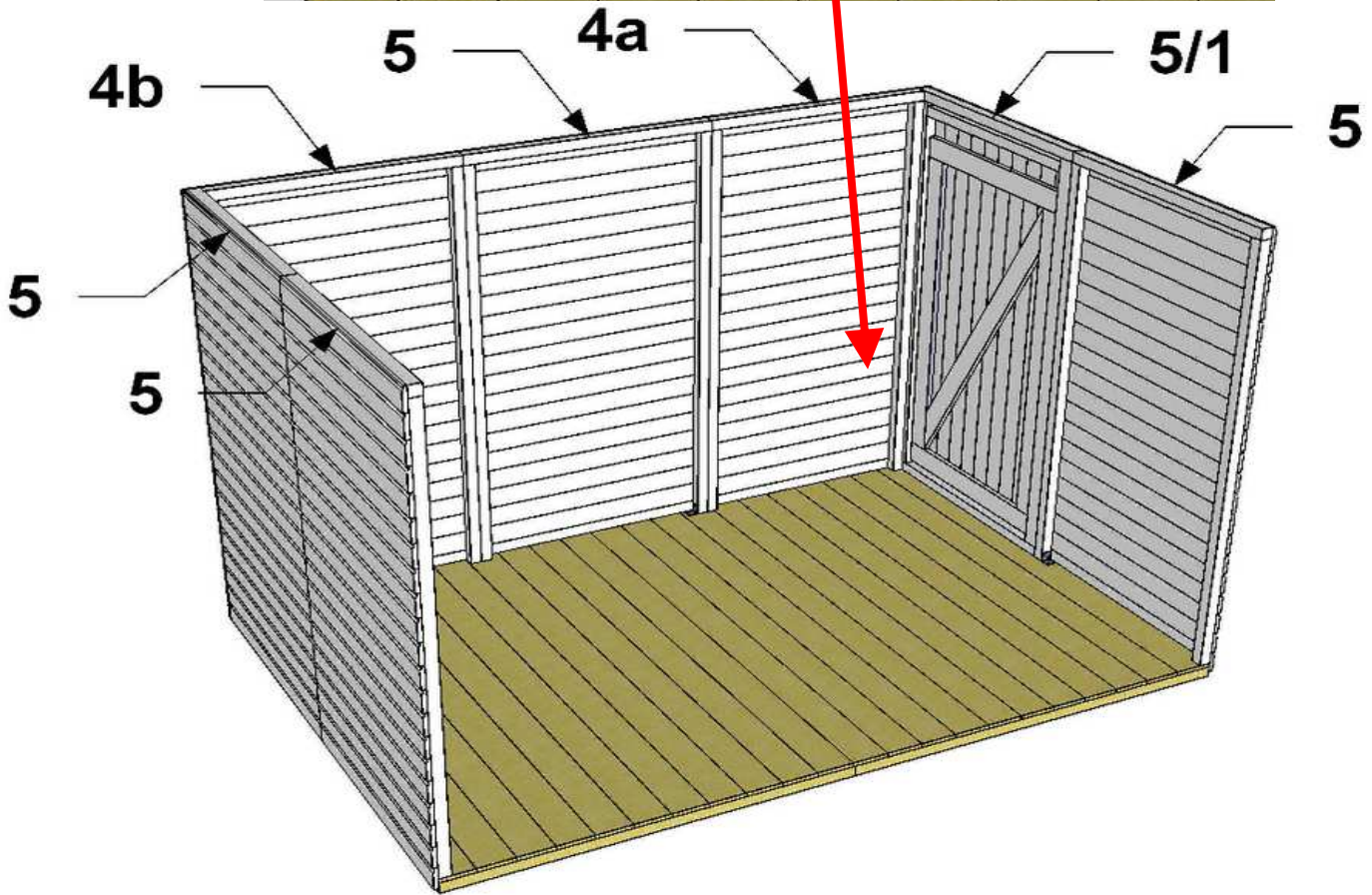
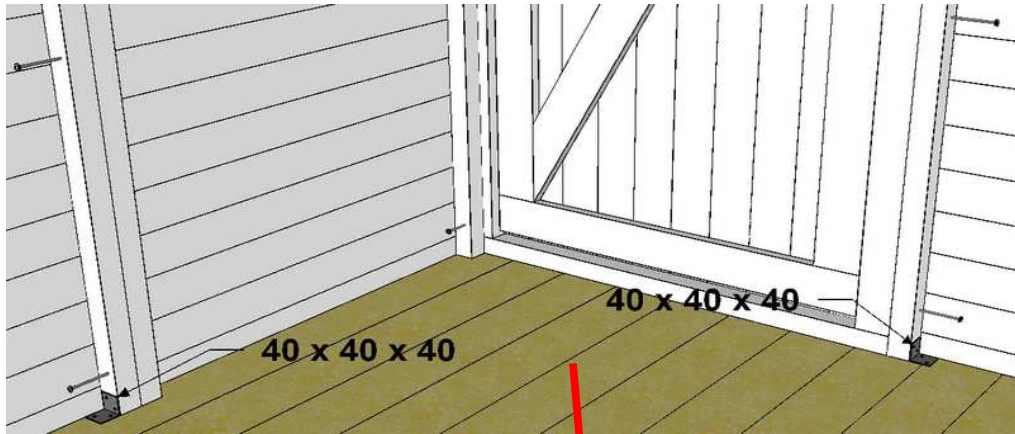

5/1	+	4a	+	5	+	4b		
		5	+	5	+	5		
5/1		5		4a		5	4,5 x 80	18
5		4b		5		5	40 x 40 x 40	4
							3,5 x 40	24

Stall 3 x 2 m. (element roof)

Assembly instruction

3/9

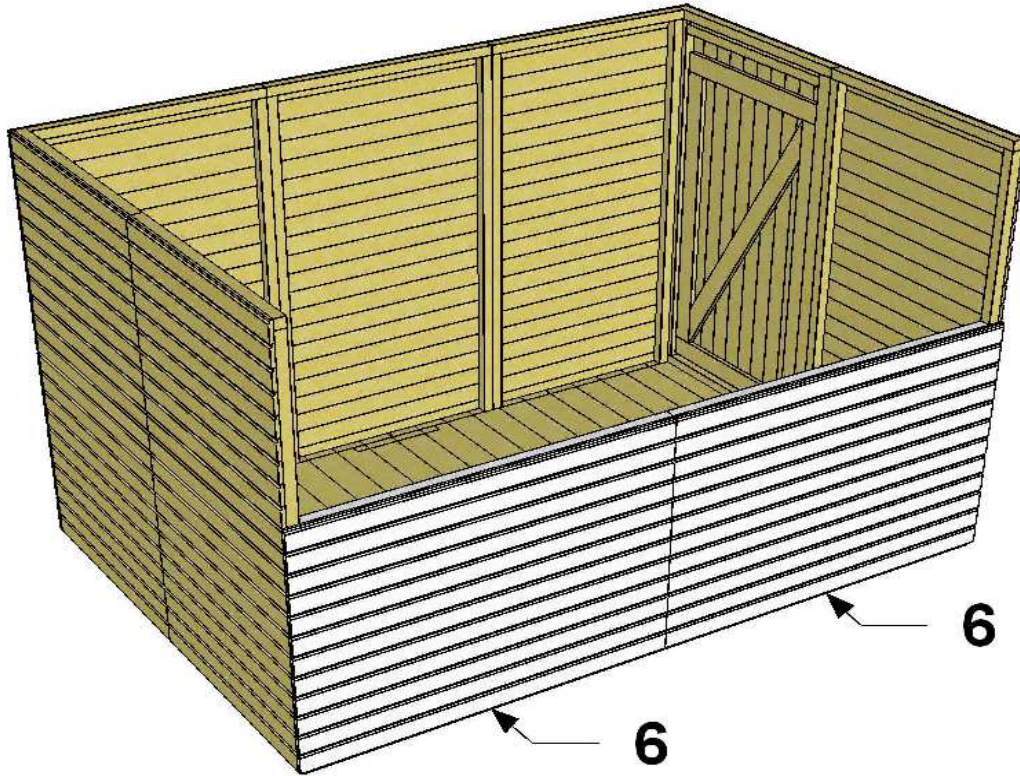

+ **6** + **6**

6 **6**

4,5 x 80	9
----------	---

40 x 40 x 40	2
--------------	---

3,5 x 40	12
----------	----

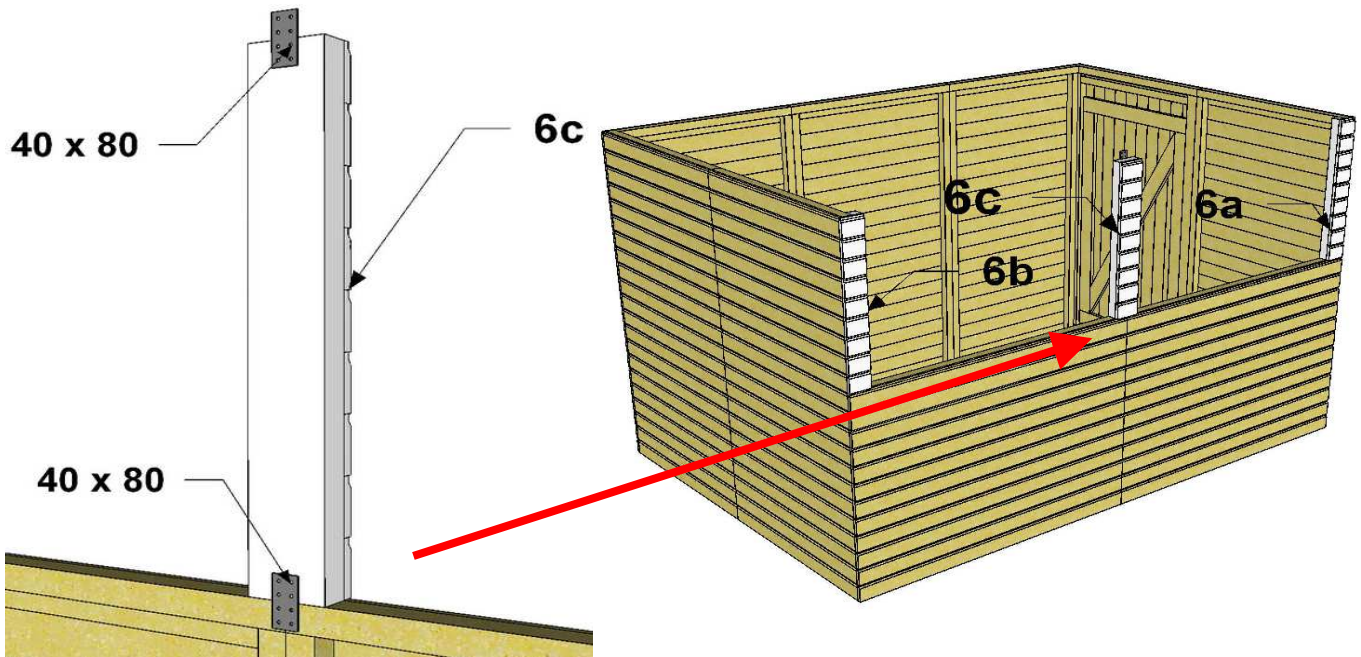

+ **6a** + **6b**

+ **6c**

4,5 x 80	6
----------	---

40 x 80	2
---------	---

3,5 x 40	16
----------	----

Stall 3 x 2 m. (element roof)

Assembly instruction

4/9

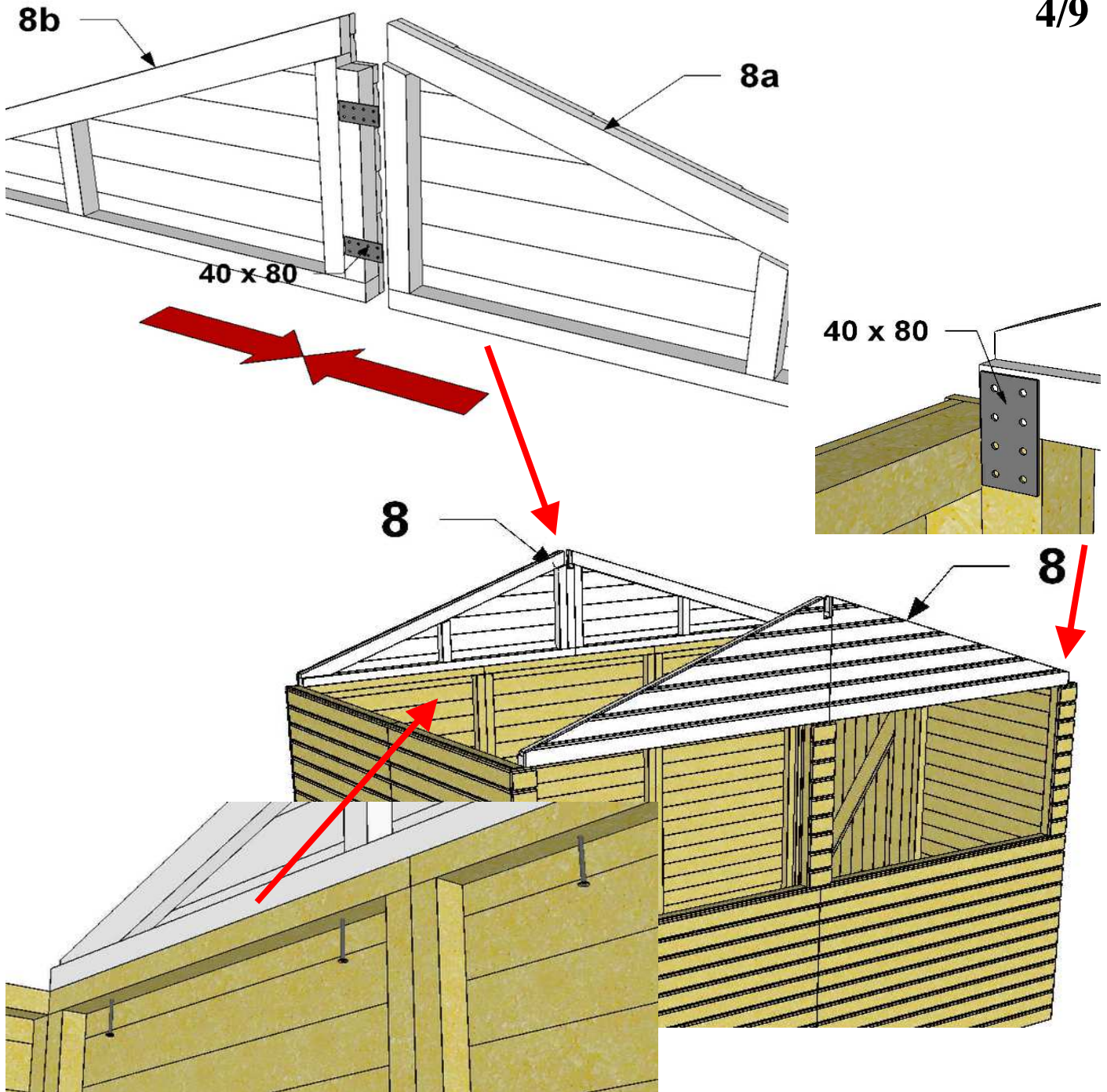

- 8a** + **8b**
- + **8** (back)
- + **8** (front)

40 x 80	4
3,5 x 40	32
4,5 x 80	6
40 x 80	2
3,5 x 40	16

Stall 3 x 2 m. (element roof)

Assembly instruction

5/9

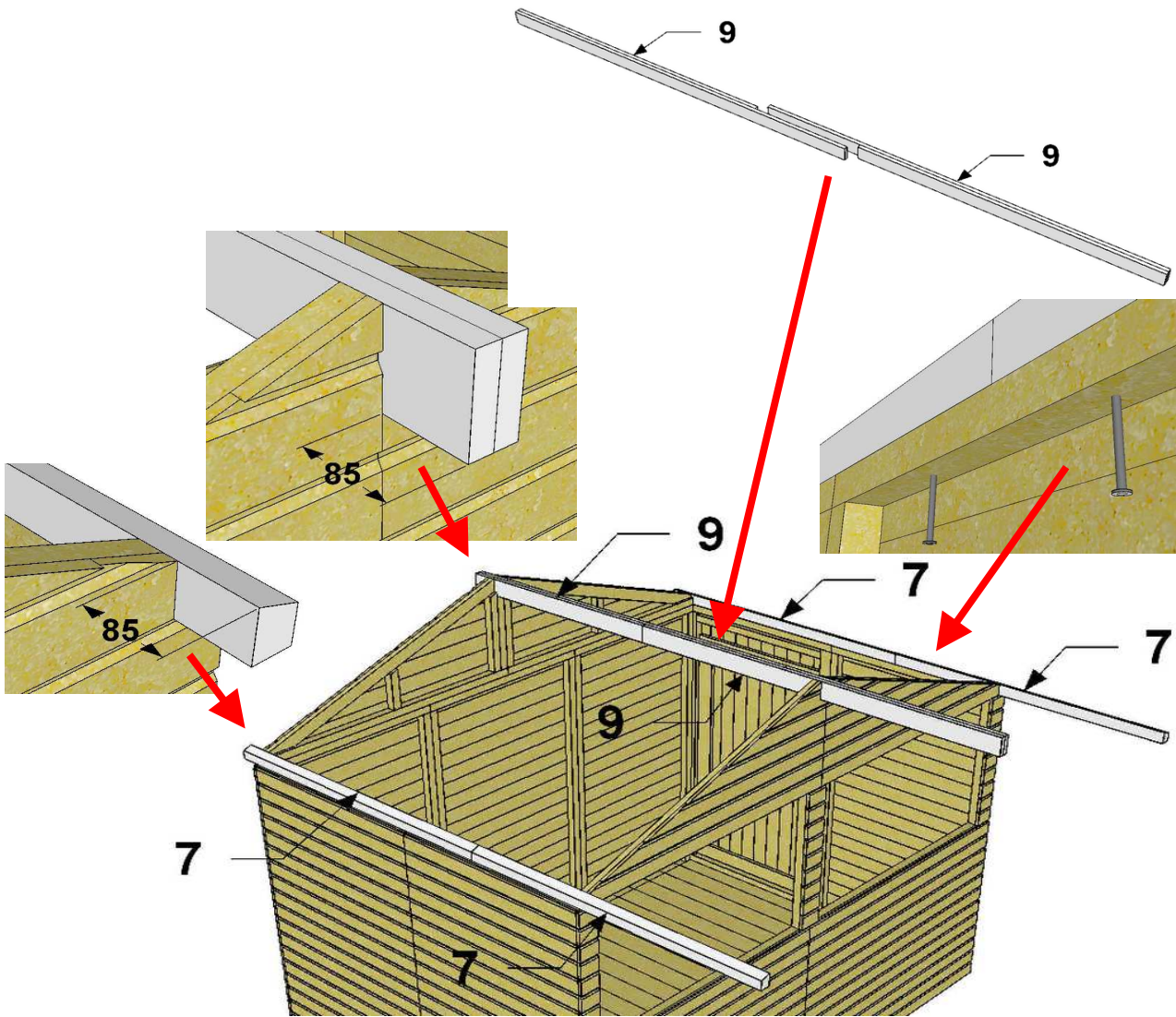

9	+	9
	+	9
	+	7

3,5 x 40	8
4,5 x 80	2
4,5 x 80	10

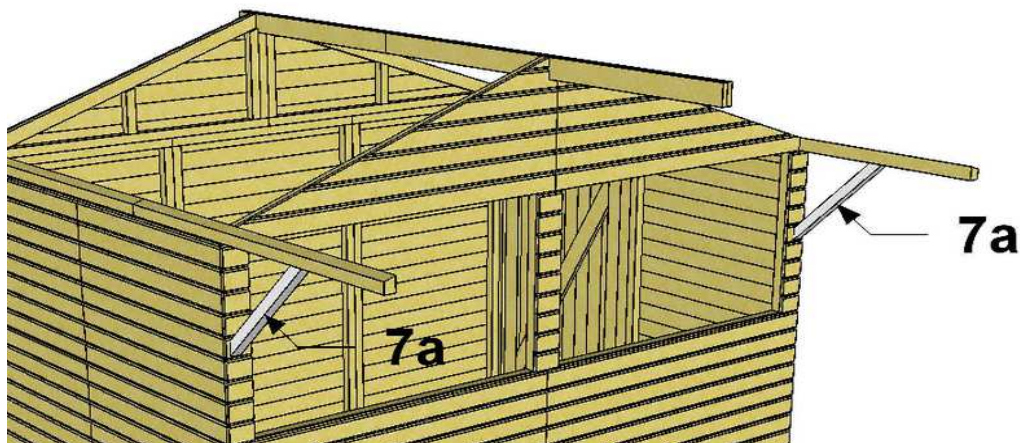

+	7a
---	-----------

4,5 x 80	4
-----------------	----------

Stall 3 x 2 m. (element roof)

Assembly instruction

6/9

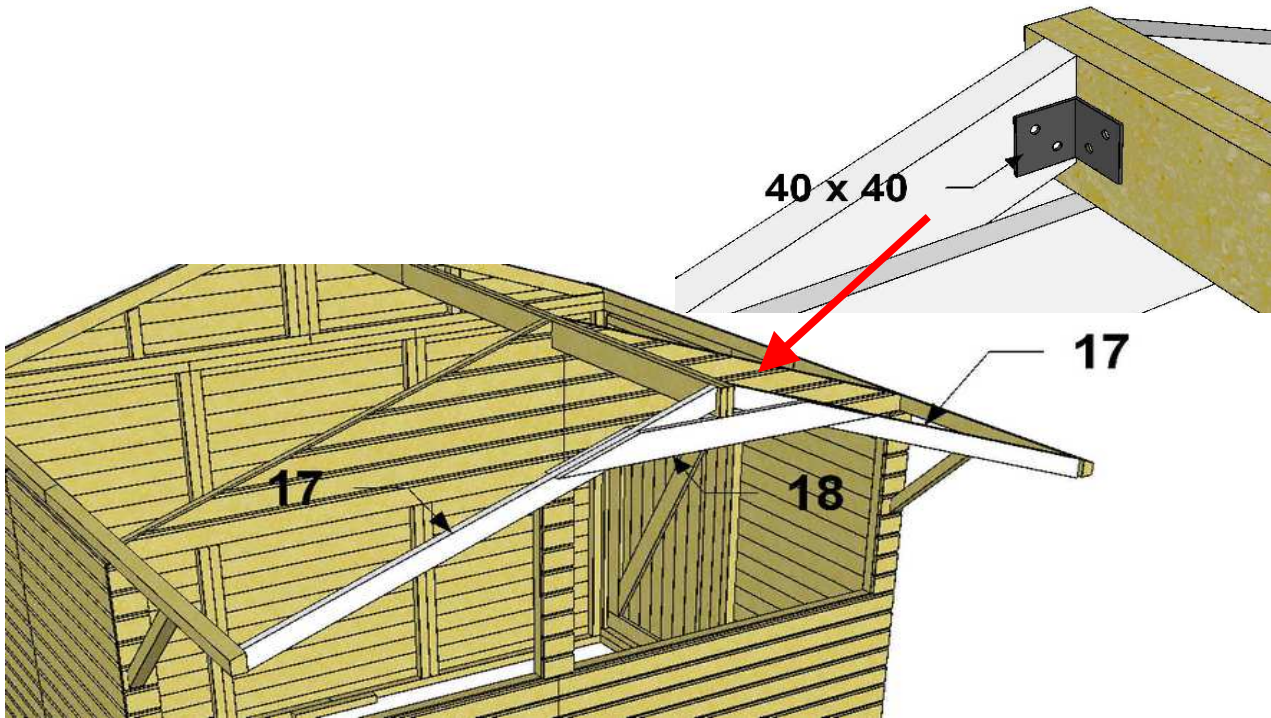

+ **17**

40 x 40 x 40	4
3,5 x 30	24

+ **18**

3,5 x 40	12
----------	----

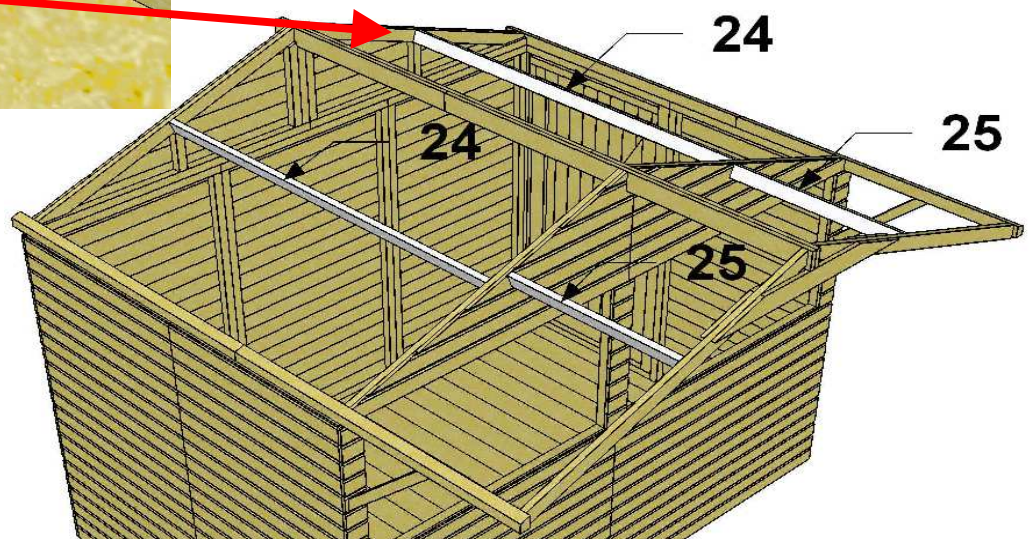
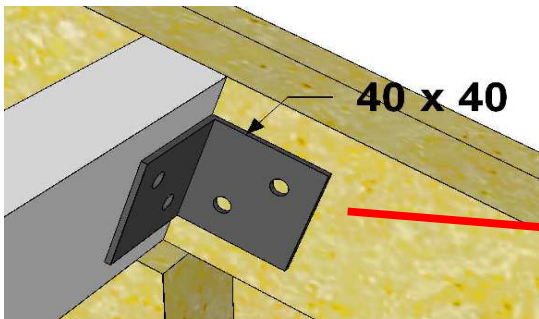

+ **24**

40 x 40 x 40	4
3,5 x 30	24

+ **25**

4,5 x 80	8
----------	---

Stall 3 x 2 m. (element roof)

Assembly instruction

7/9

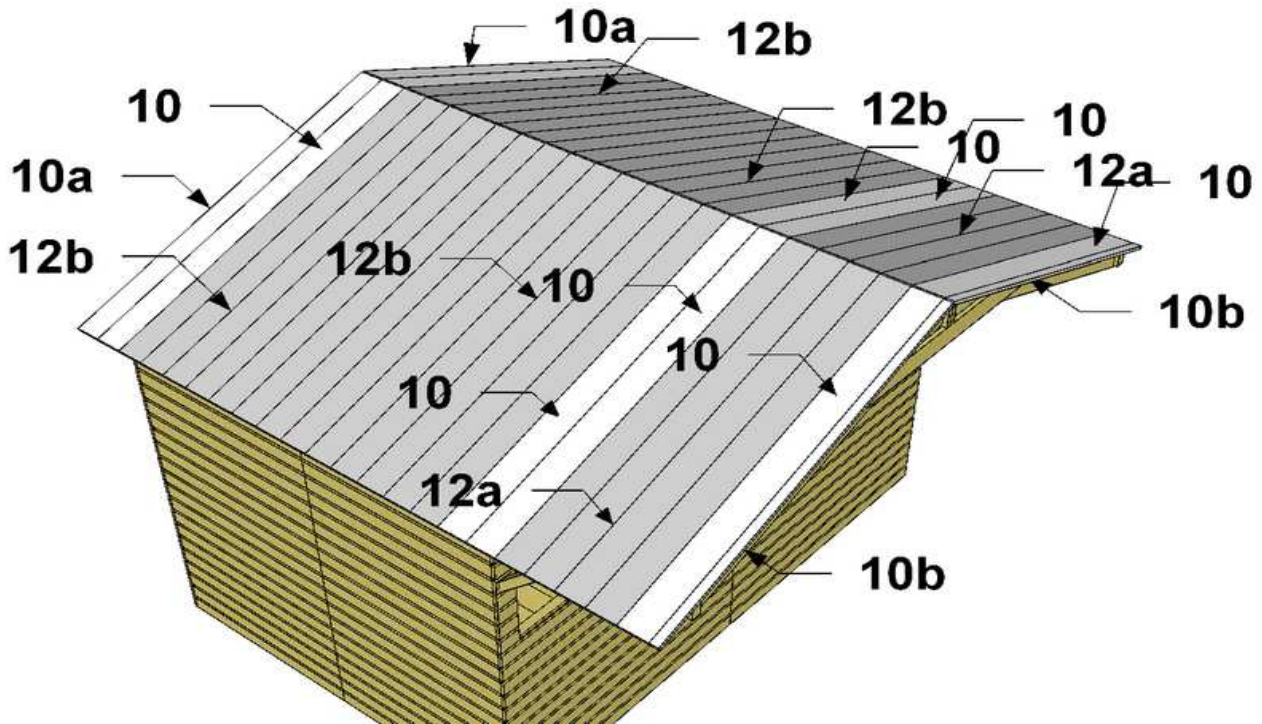

	+	10a		3,5 x 40	12
+	12b	+	12b	3,5 x 40	36
	+	10		3,5 x 40	24
	+	12a		3,5 x 40	18
	+	10b		3,5 x 40	8

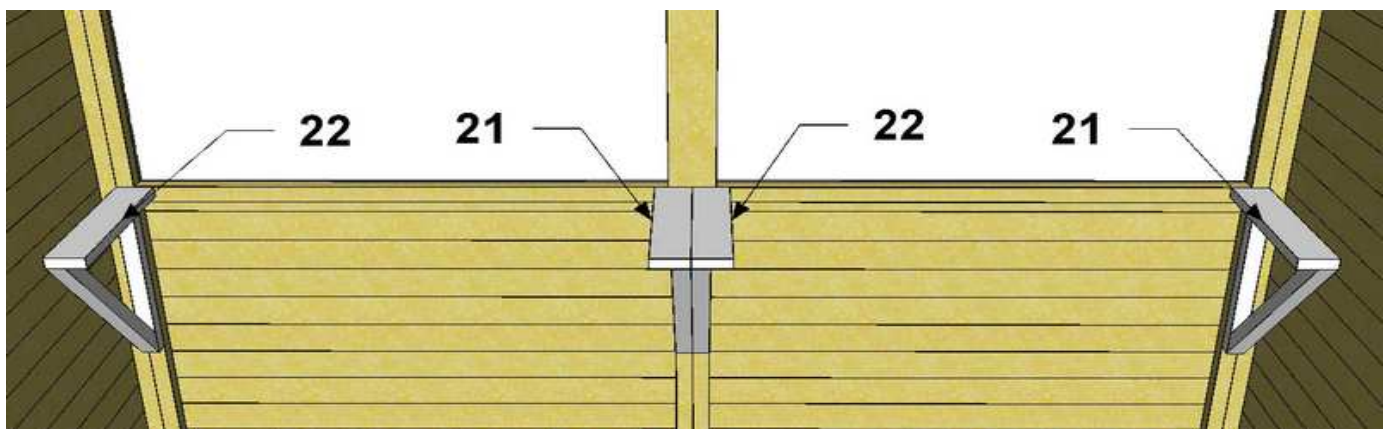

+	21	+	22	4,5 x 80	8
---	-----------	---	-----------	----------	---

Stall 3 x 2 m. (element roof)

Assembly instruction

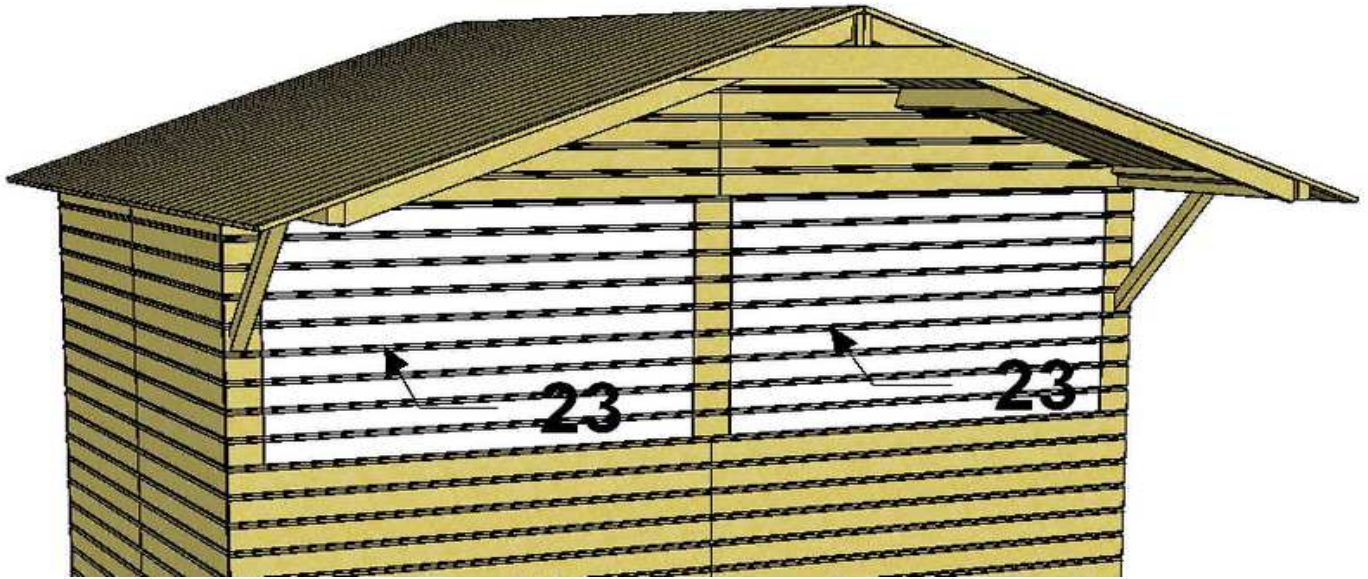

+ **23** (20)

bolt M6	8
wing nut M6	8

from inside

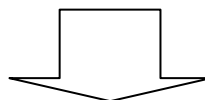
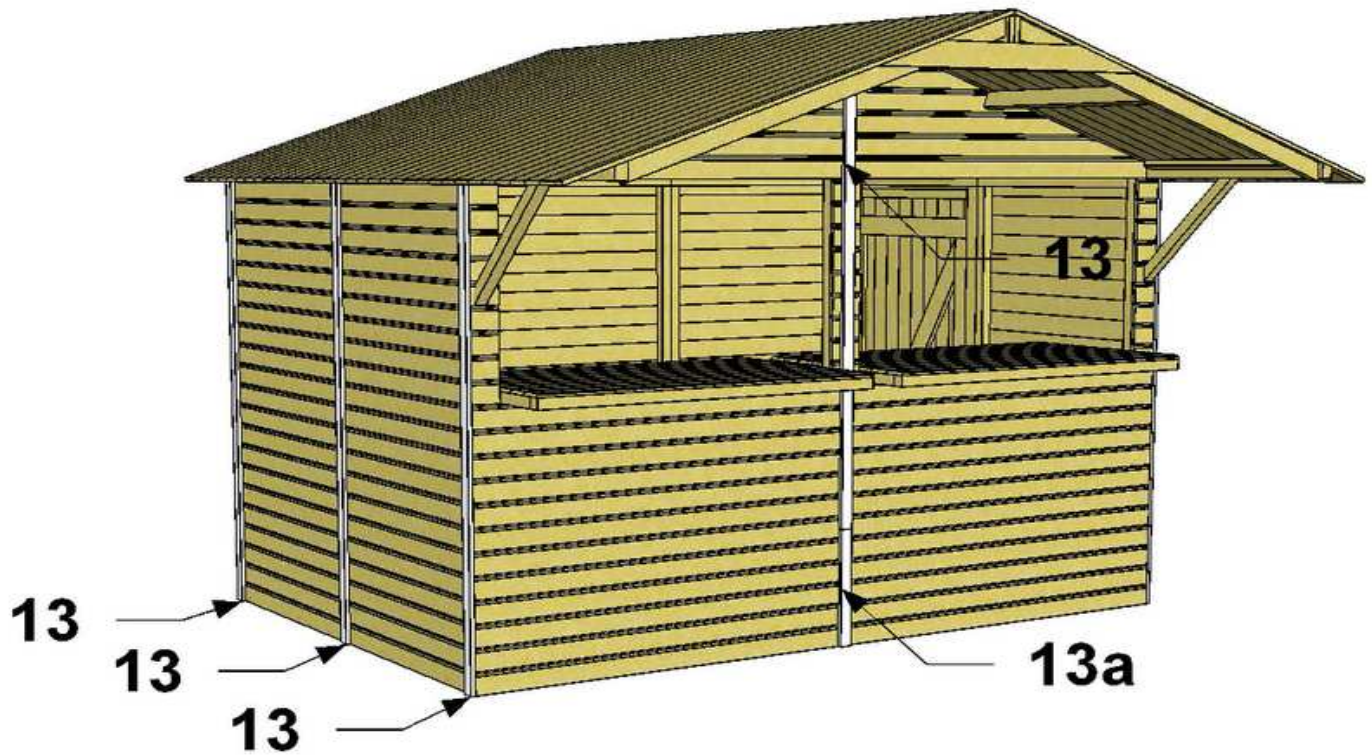

Stall 3 x 2 m. (element roof)

Assembly instruction

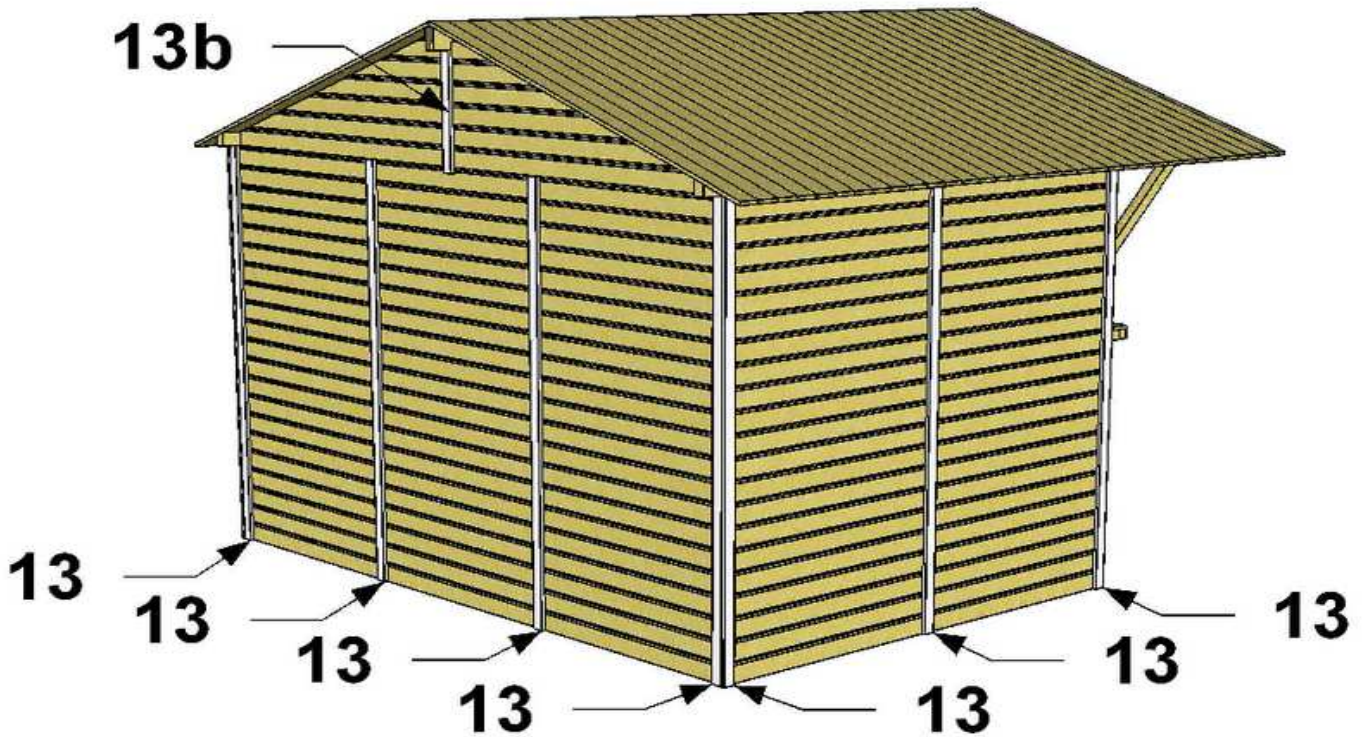

13 + **13a** + **13b**

3,5 x 40	37
-----------------	-----------

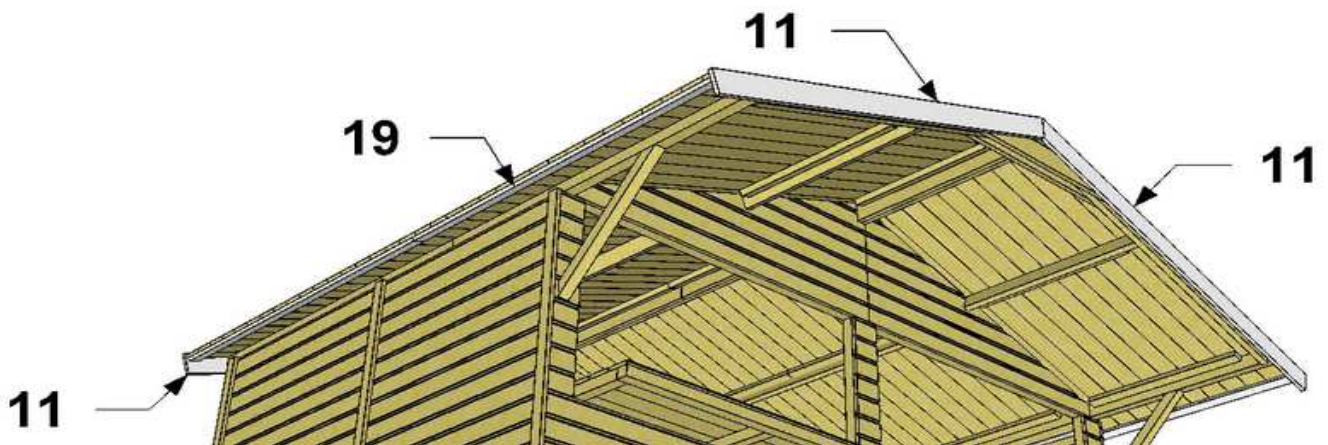

+ **11**

3,5 x 40	16
-----------------	-----------

+ **19**

3,5 x 30	24
-----------------	-----------

+ **16**

3,5 x 40	4
3,5 x 30	6