

Assembly Instruction

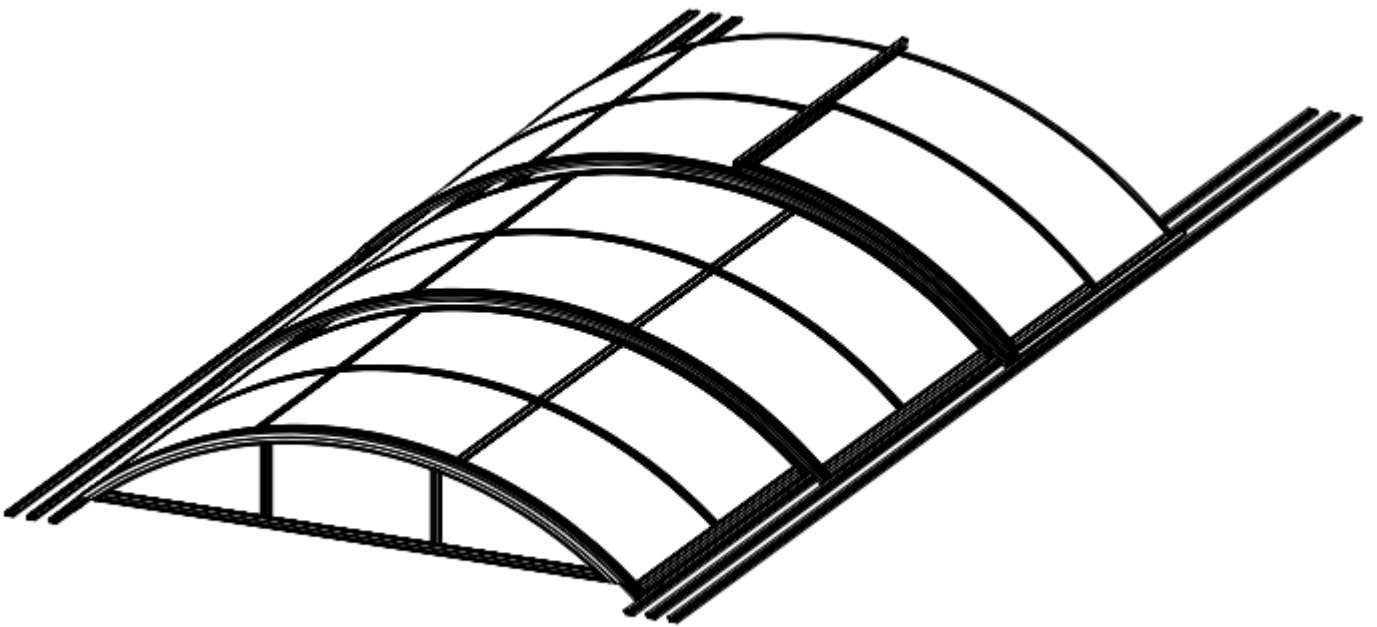

MODEL: 142-2-5

PRODUCT SIZE(LxWxH):390x850x88cm

PLEASE READ CAREFULLY BEFORE ASSEMBLY

Assembly and Maintenance Advice

1. For safety purposes, we strongly recommend that this product is assembled by at least three persons.
2. Some components have sharp metal edges. Please be careful when handling metal components. Please wear gloves, shoes and safety goggles during assembly.
3. DO NOT climb or stand on the roof. Heavy articles should not be leaned against the greenhouse.
4. Keep the roof and gutter clear of snow, dirt & leaves. Allowing snow to build up on the roof may damage the product.
5. When your product needs cleaning, use a mild detergent solution and rinse with cold clean water. Do not use acetone, abrasive cleaners or strong detergents to clean the panels.

Tools Provided:

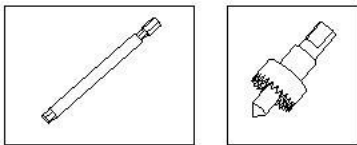



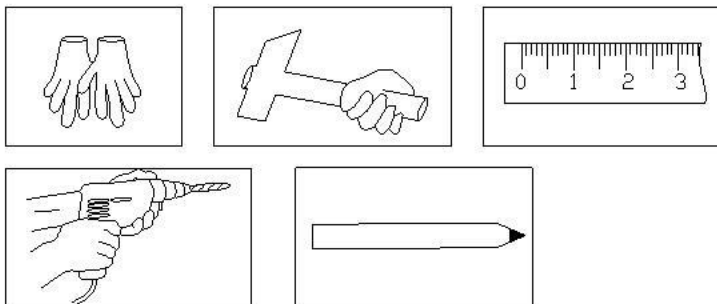

















Tools Required when Assembly (Not Provided)

















Assembly at least by three Persons



142-2-5 (ALU Box)

PART	NO	QTY
	L01A	6
	01-L02A	1
	01-L02B	1
	02-L02A	2
	02-L02B	1
	03-L02A	1
	03-L02B	1
	01-L02G	2
	01-L02H	2
	L04A	12
	L05A	2
	L06A	12
	L08A	1
	L08B	1
	L09A	2
	L11	24
	L12	6
	L13	4
	K1-1	1
	K3-1	1



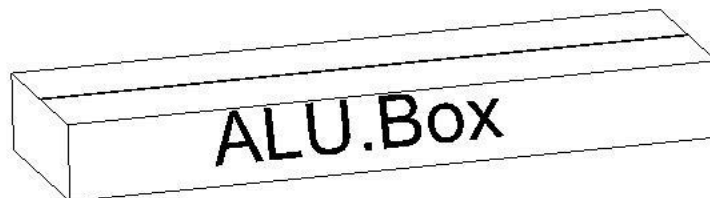





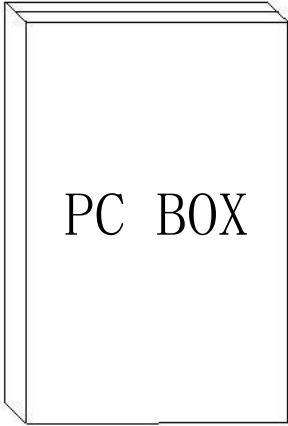

PART	NO	QTY
	W01	4
	W02	1
	CX	4
	J01	106
	J02	60
	J03	9M
	HL	18
	HL2	8
	S01 M6X35	18
	M01	26
	M02	18
	Z01 M6X60	104
	Z02 M4.2X16	146
	Z03 M4.2X25	8
	Z04 Ø6X16	8

















142-2-5 (PC Box)

PART	NO	QTY
<input type="checkbox"/>	Y1	4
<input type="checkbox"/>	Y2	6
<input type="checkbox"/>	Y3	6
<input type="checkbox"/>	Y9	1
<input type="checkbox"/>	Y10	4



PART	NO	QTY
	L01A	2
	01-L02A	1
	01-L02B	1
	01-L02G	2
	01-L02H	2
	L04A	4
	L05A	2
	L08A	1
	L09A	2
	L11	8
	K1-1	1

PART	NO	QTY
	W01	4
	W02	1
	CX	1
	J01	26
	HL	6
	HL2	8
	S01 M6X35	6
	M01	14
	M02	6
	Z01 M6X60	20
	Z02 M4.2X16	53
	Z03 M4.2X25	2
	Z04 Ø6X16	8







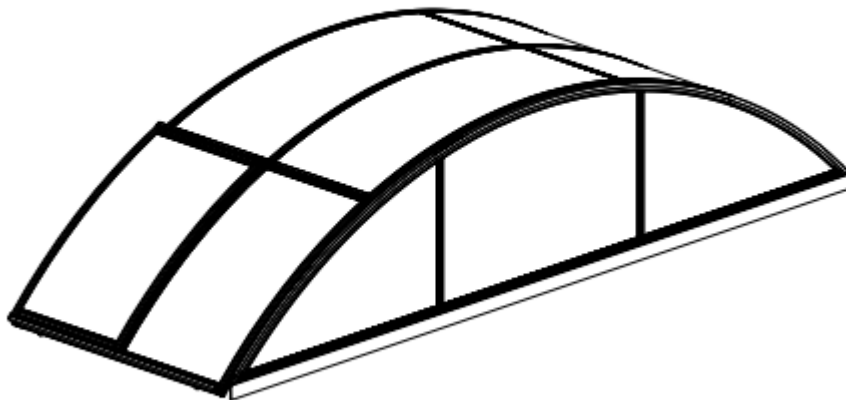

PART	NO	QTY
	Y1	4
	Y9	1
	Y10	1

PART	NO	QTY
	J03	4.29M

K1 Assembly

K1



PART	NO	QTY
	L01A	2
	K1-1	1
	L08A	1
	HL	6
	M02	6
	S01 M6X35	6
	M01	6
	Z01 Ø6X60	4
	Z02 M4.2X16	5

Fix the wheels onto L01A (3PCS),
using S01 & M01.

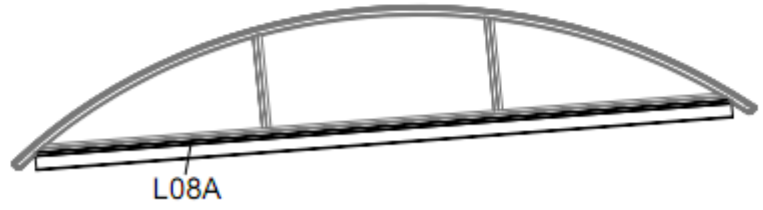
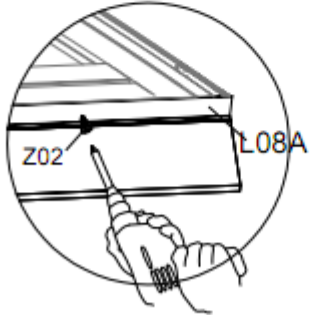
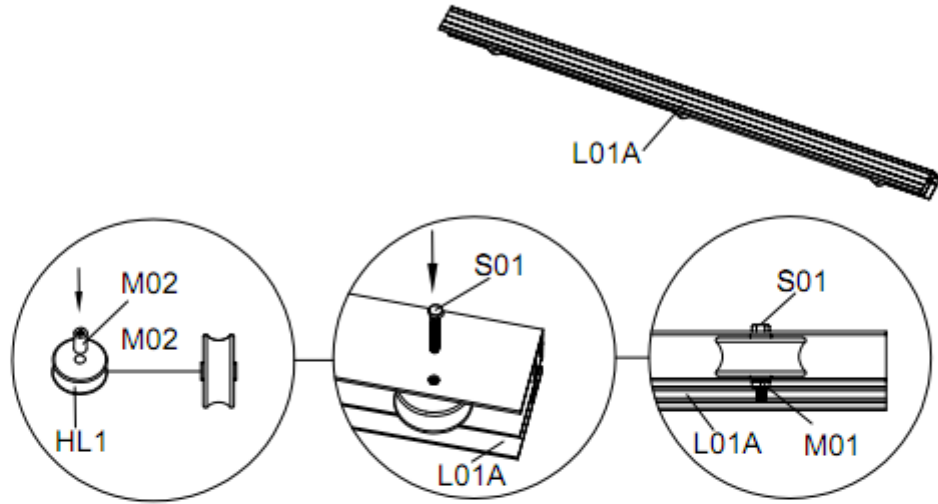



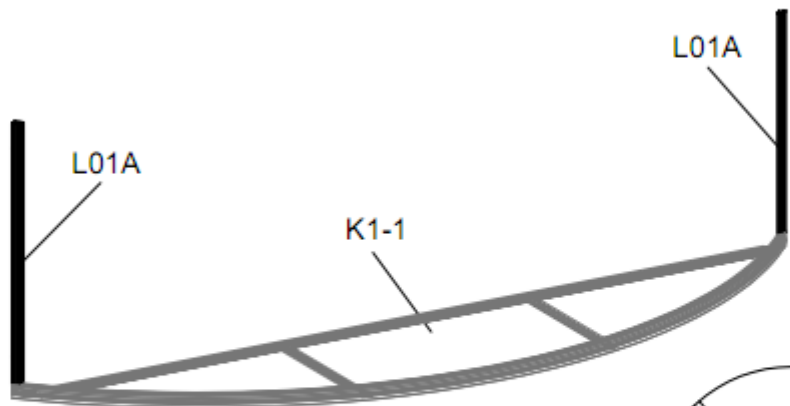

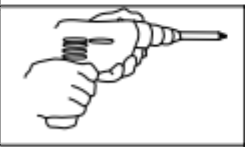
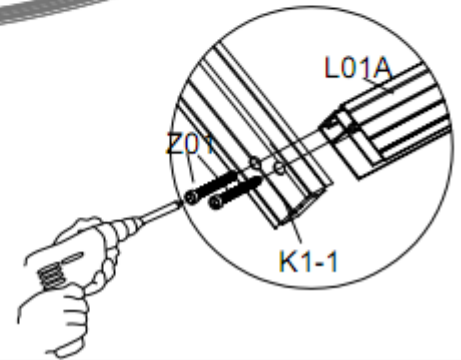

Fix L08A onto K1-1, using Z02.



Fix L01A * 2PCS onto K1-1 using Z01,
shown as above.



PART	NO	QTY
	L04A	2
	01-L02B	1
	L11	4
	Y1	2
	Z02 M4.2X16	16
	Z01 Ø6X60	4

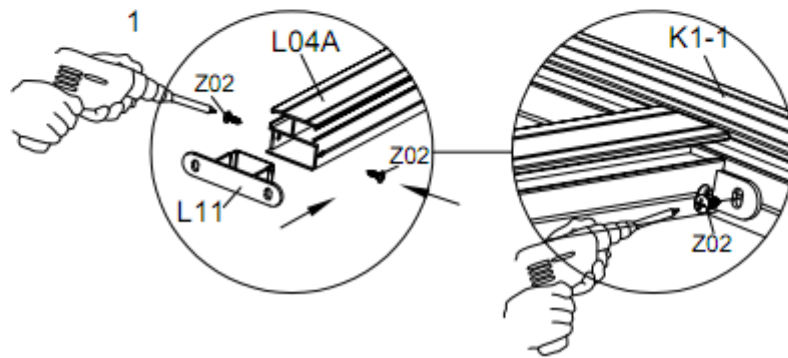
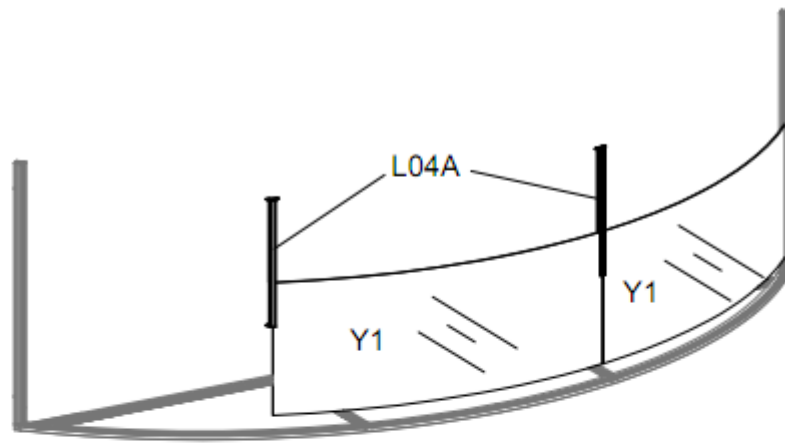

1. Insert L11 into L04A as shown, and fix it with L04A using Z02;
2. Fix L04A onto K1-1 as shown, using Z02.

Attention: Y1 must be placed into the channel of L04A & L01A at the same time.
Make sure all the panels are in the right position before fixing Z02 tight.

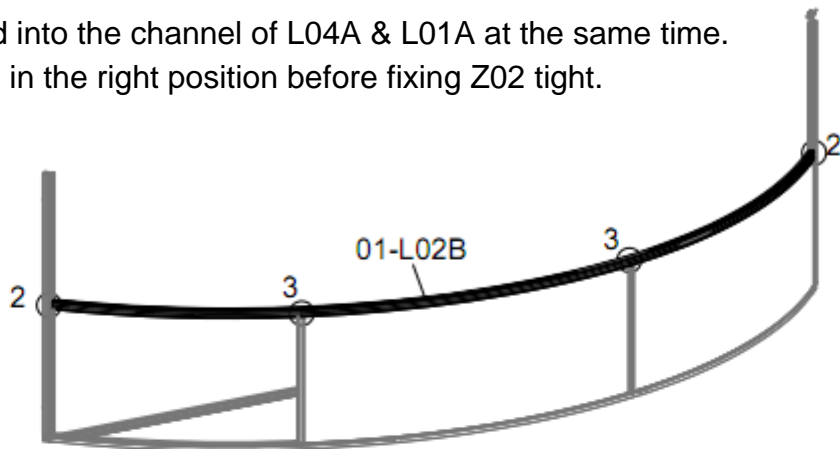

Fix 01-L02B with L01A and L04A, using Z01 & Z02.

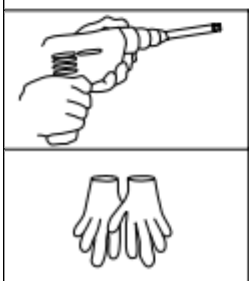
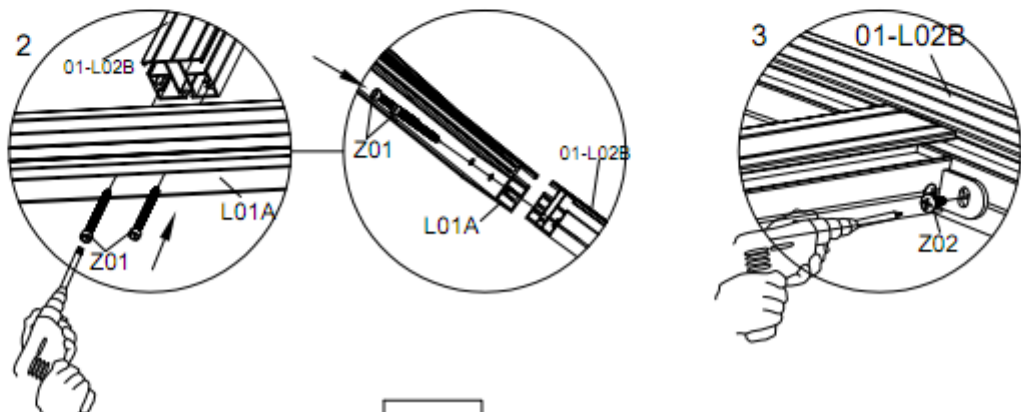

PART	NO	QTY
	01-L02A	1
	L04A	2
	L11	4
	Y1	2
	Y9	1
	Z02 M4.2X16	16
	Z01 Ø6X60	4

Attention: Y1 & Y9 must be placed into the channel of L04A/L01A at the same time.
Make sure all the panels are in the right position before fixing Z02.

PART	NO	QTY
	J03	4.29M

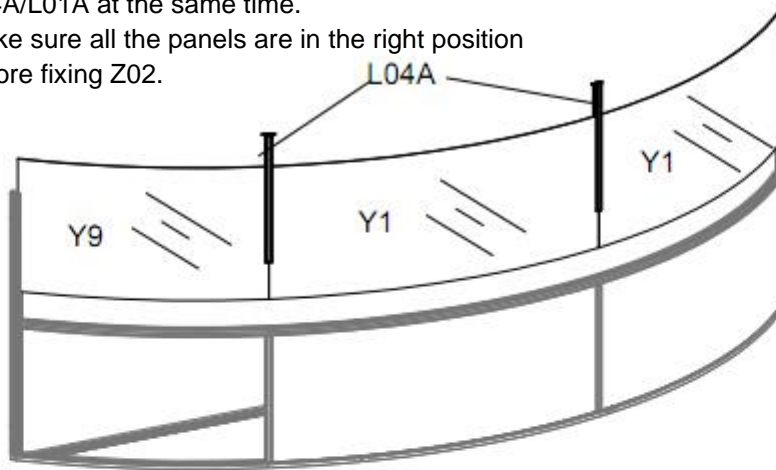

Fix L04A onto 01-L02B as shown, using Z02.

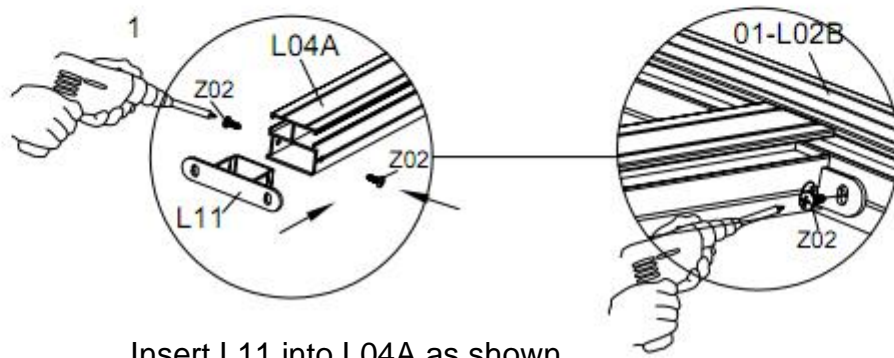

Insert L11 into L04A as shown, and fix it with L04A using Z02;

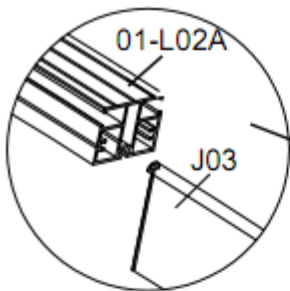



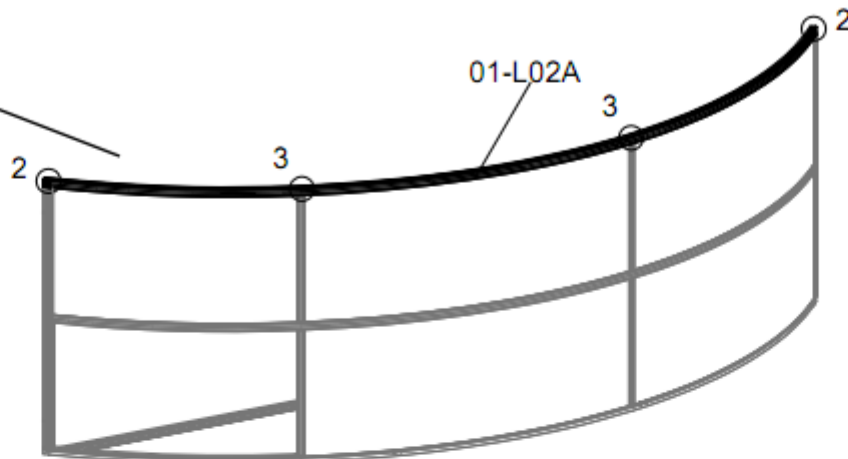

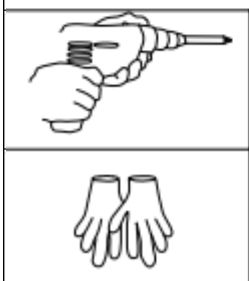
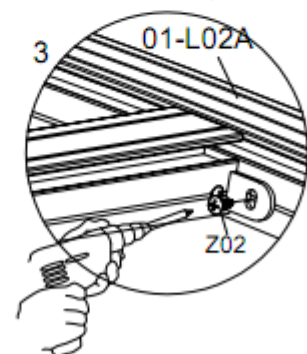
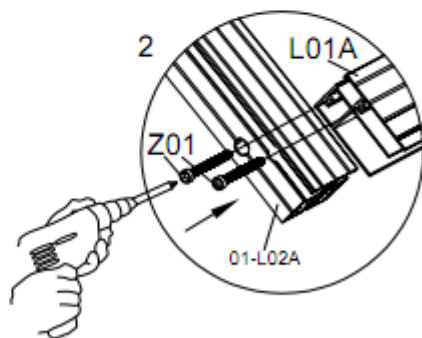

Slide Rubber J03 into the channel of 01-L02A.





Fix 01-L02A with L01A and L04A, using Z01 & Z02.

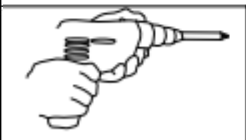
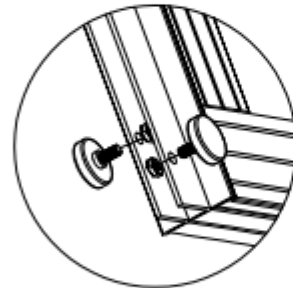
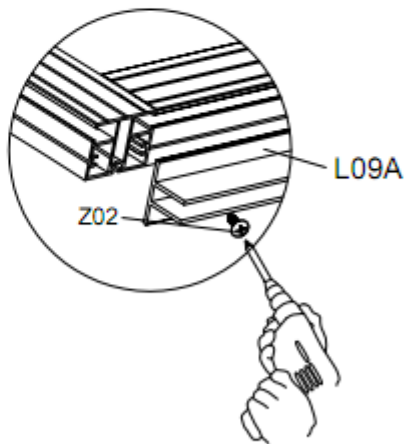
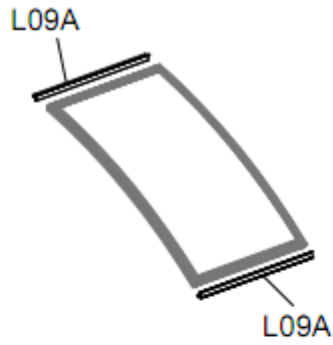
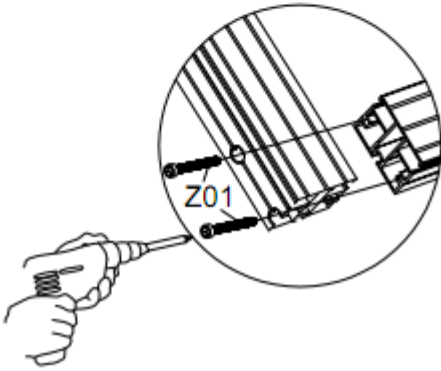
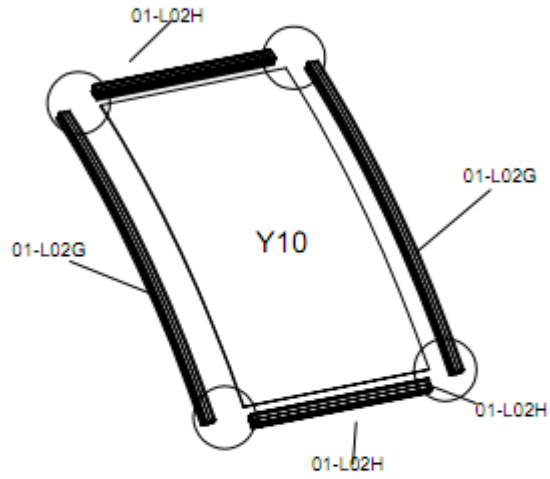

PART	NO	QTY
	01-L02G	2
	01-L02H	2
	L09A	2
	HL2	8
	Y10	1
	Z02 M4.2X16	8
	Z01 Ø6X60	8
	M01	8

Window Assembly





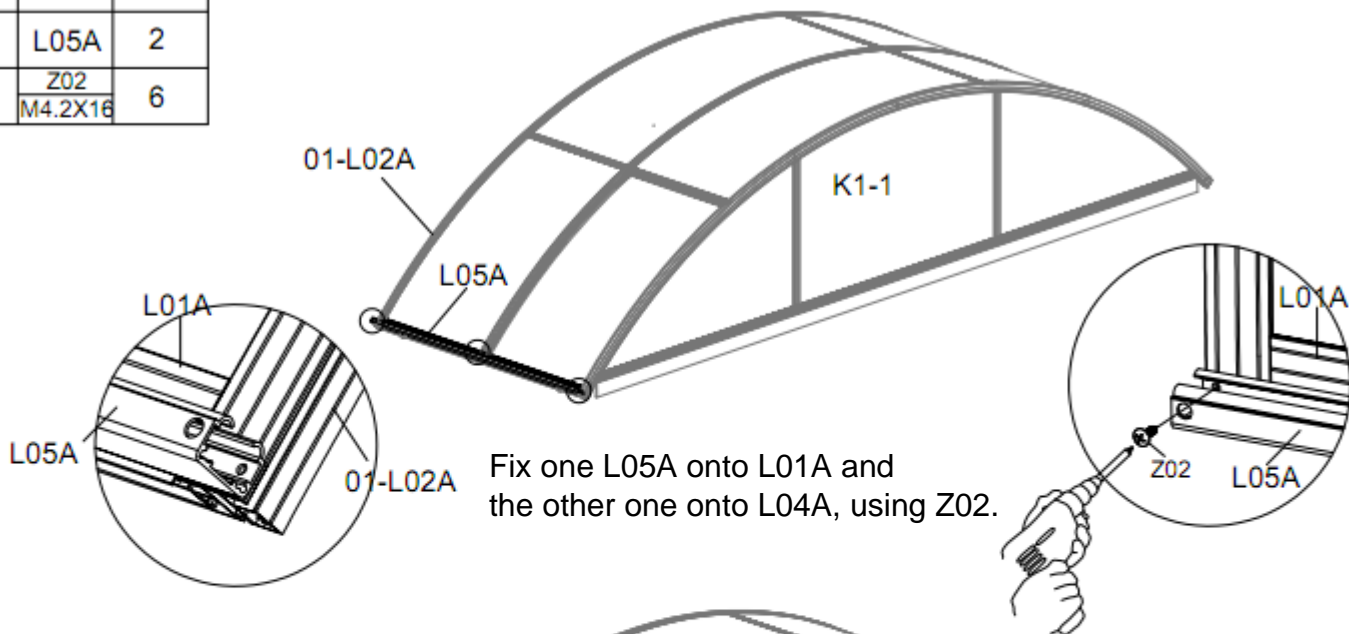

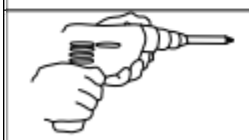
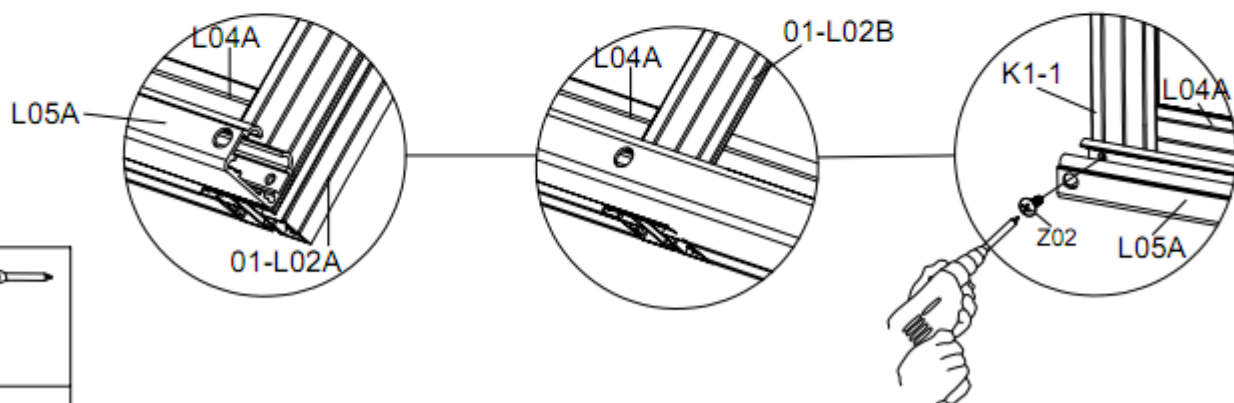
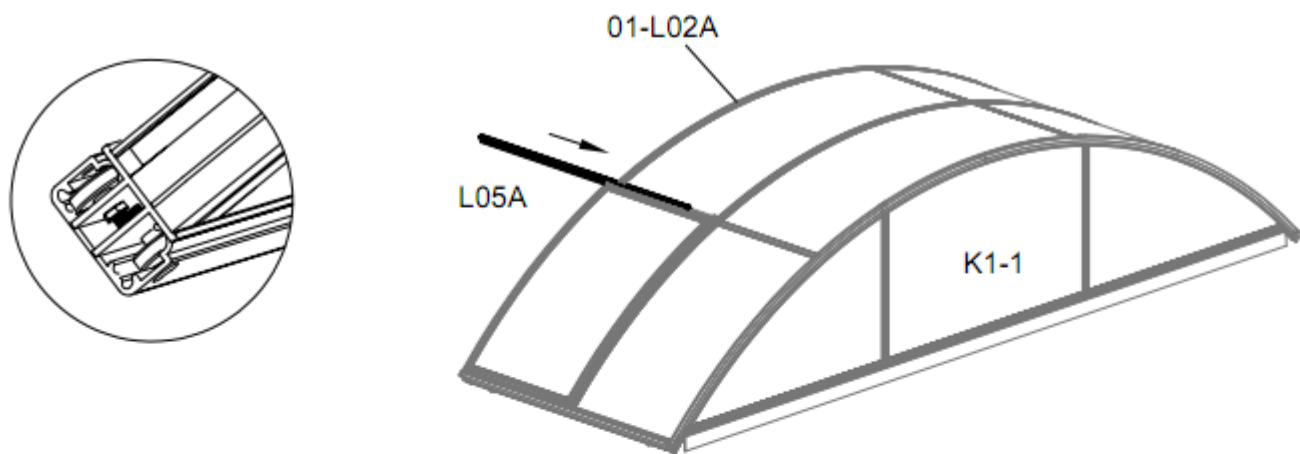
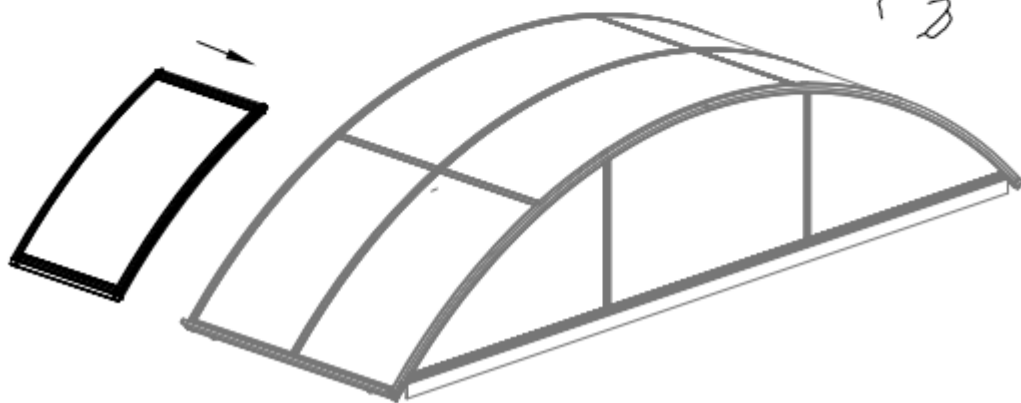

PART	NO	QTY
	L05A	2
	Z02	6
	M4.2X16	



Fix one L05A onto L01A and the other one onto L04A, using Z02.



PART	NO	QTY
	CX	1
	J01	26
	Z02 M4.2X16	2
	Z03 M4.2X25	2
	Z04 Ø6X16	8
	W01	4
	W02	1

Fix W01 (4PCS) onto both ends of L05A, using Z04.

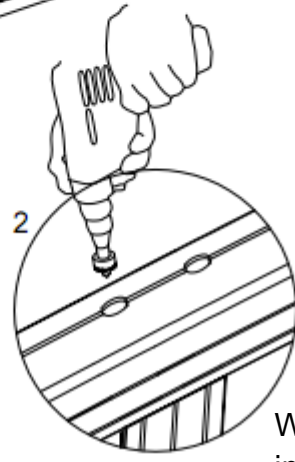
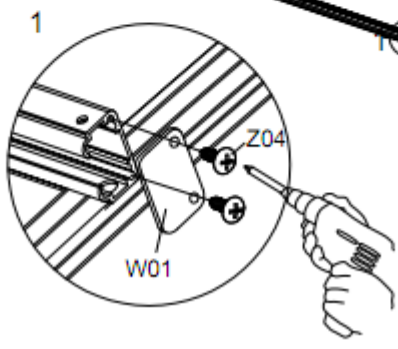
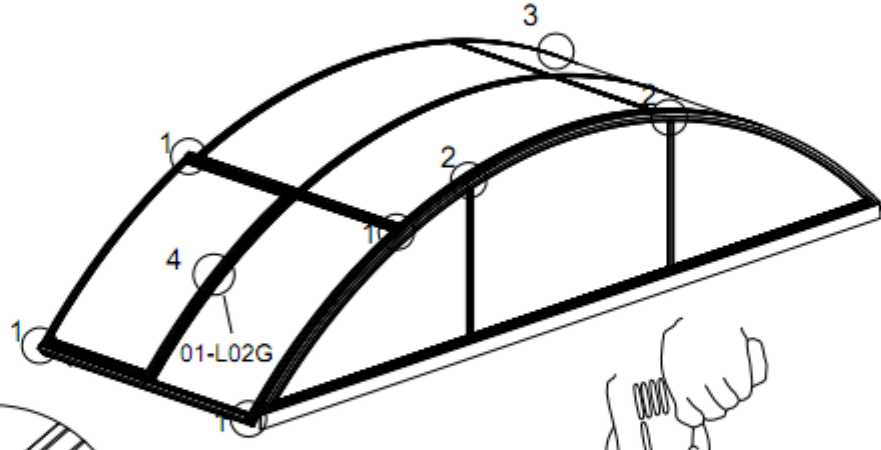

Widen the holes into Dia 14mm, using a reamer and a power screwdriver.

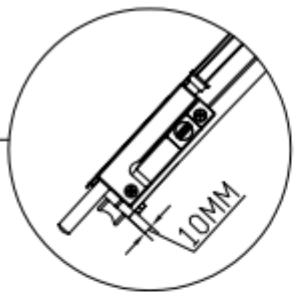
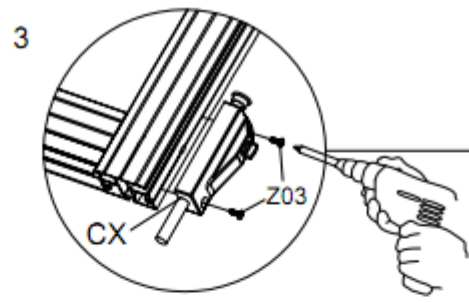

Fix CX onto 01-L02A 10MM away from the bottom, using Z03.

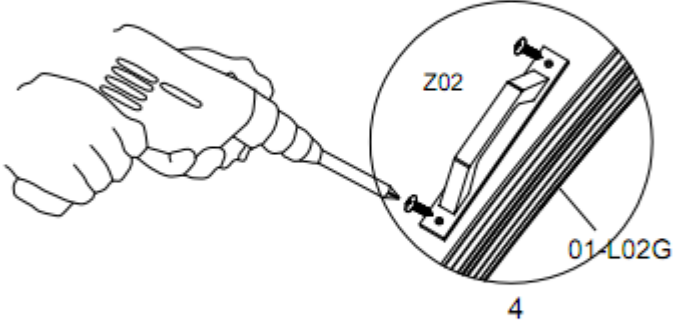



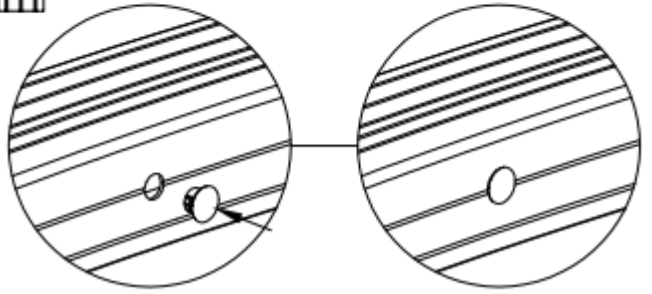



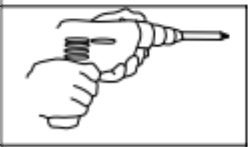







Fix the handle W02 onto window profile 01-L02G, using Z02.





Cover all the holes with J01



PART	NO	QTY
	L01A	2
	02-L02A	2
	02-L02B	1
	L04A	4
	L11	8





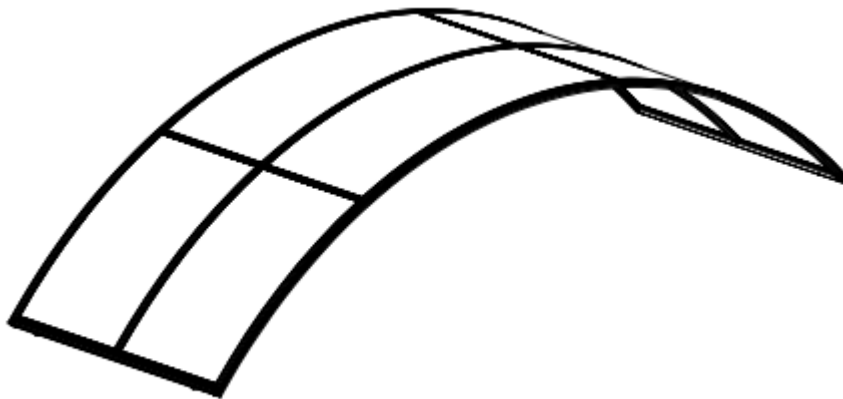

PART	NO	QTY
	CX	2
	J01	8
	HL	6
	S01 M6X35	6
	M01	6
	M02	6
	Z01 M6X60	12
	Z02 M4.2X16	32
	Z03 M4.2X25	4

PART	NO	QTY
	Y2	6

PART	NO	QTY
	J03	3.97M

K2







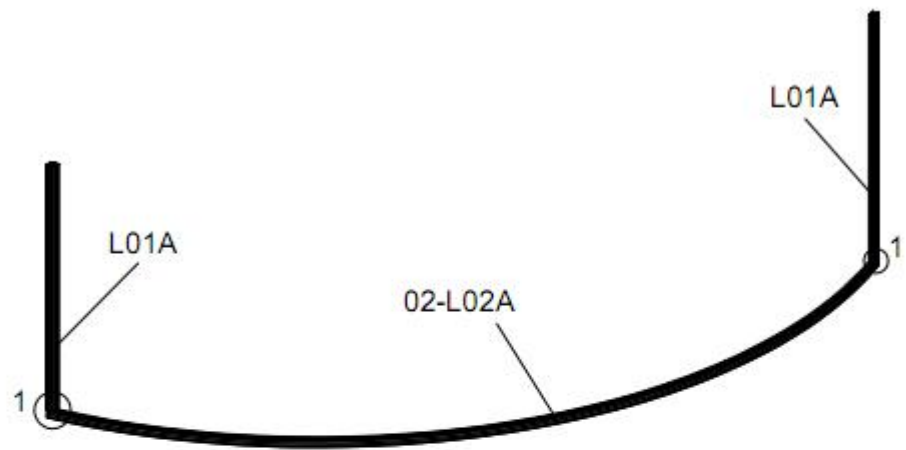
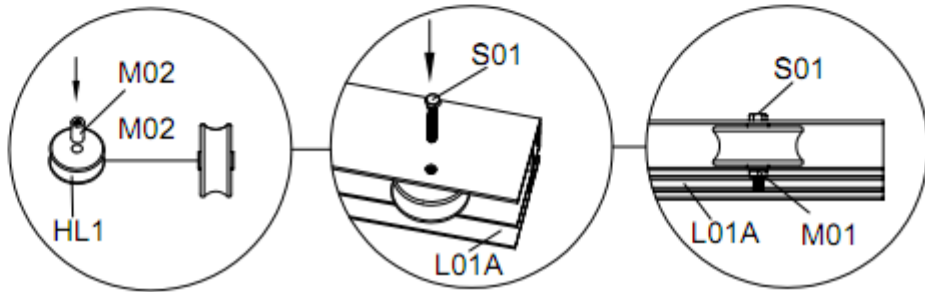
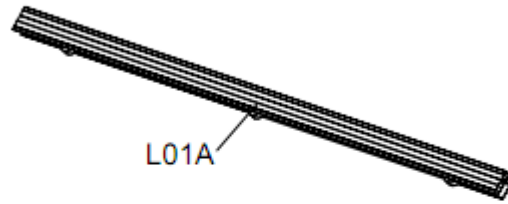

PART	NO	QTY
	L01A	2
	02-L02A	1
	HL	6
	M02	6
	S01 M6X35	6
	M01	6
	Z01 M6X60	4

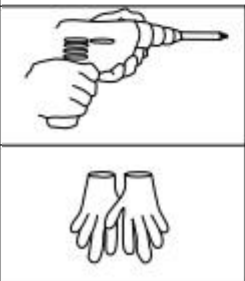
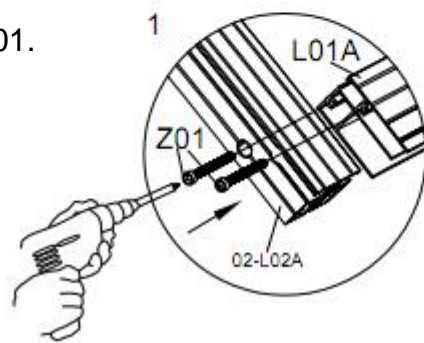
Fix the wheels onto L01A (3PCS),
using S01 & M01.



Fix L01A * 2PCS onto 02-L02A using Z01.



PART	NO	QTY
	L04A	2
	02-L02B	1
	L11	4
	Y2	3
	Z02	16
	Z01 M6X60	4

1. Insert L11 into L04A as shown, and fix it with L04A using Z02;





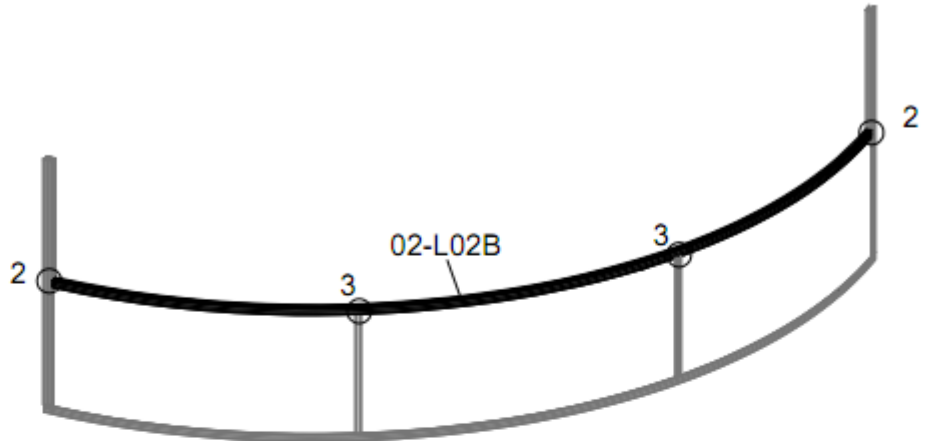
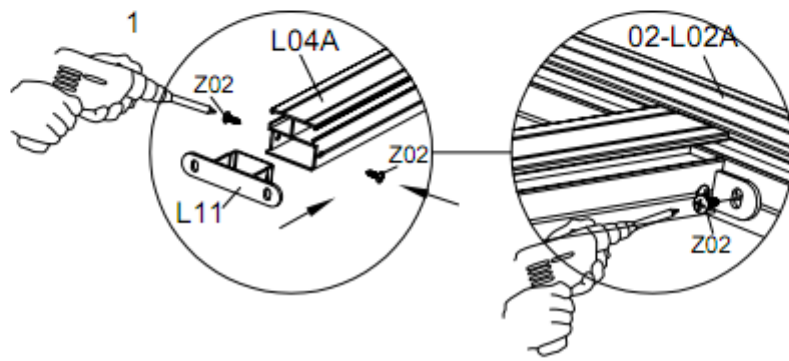
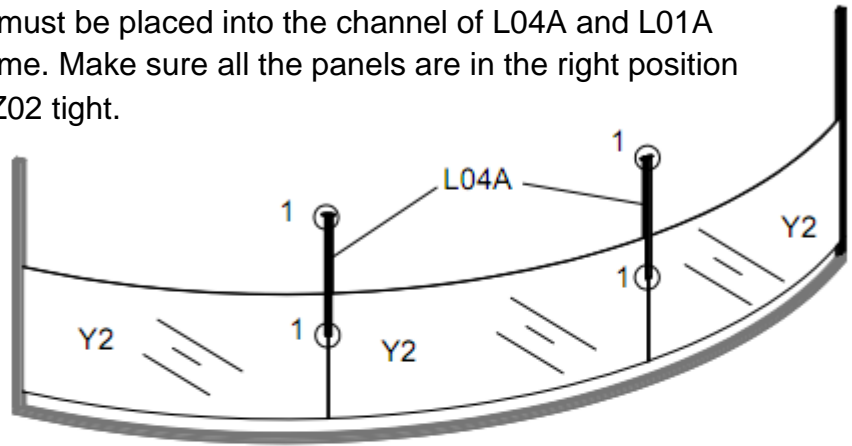

2. Fix L04A onto 02-L02A as shown, using Z02.

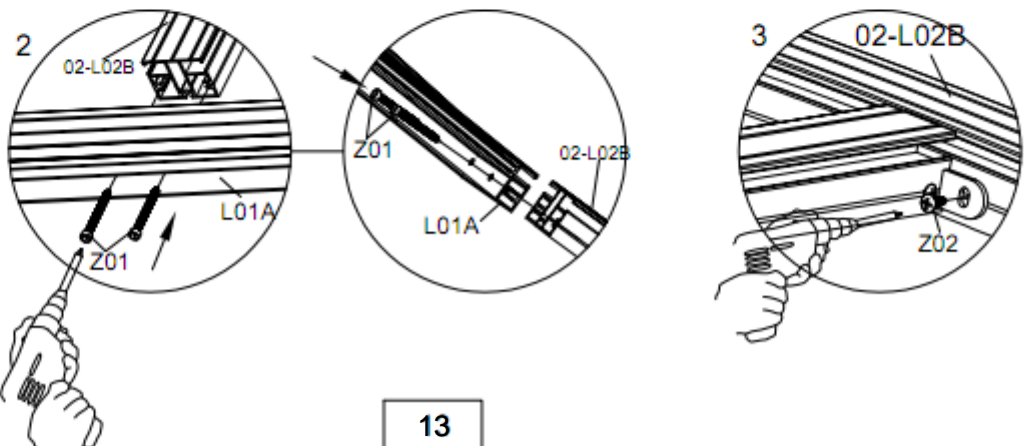
Attention: Y2 must be placed into the channel of L04A and L01A at the same time. Make sure all the panels are in the right position before fixing Z02 tight.





Fix 02-L02B with L01A and L04A, using Z01 & Z02.

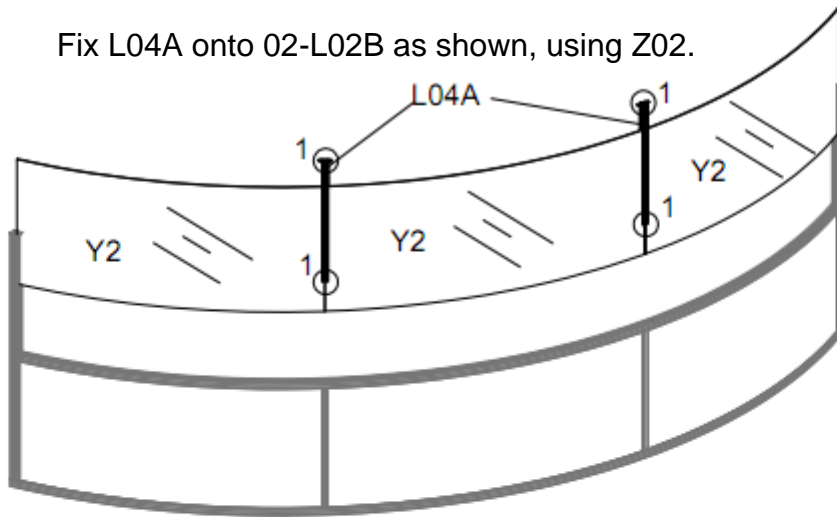

PART	NO	QTY
	02-L02A	1
	L04A	2
	L11	4
	Y2	3
	Z02	16
	Z01 M6X60	4

Fix L04A onto 02-L02B as shown, using Z02.



PART	NO	QTY
	J03	3.97M

Attention:
Y2 must be placed into the channel of L04A/L01A at the same time. Make sure all the panels are in the right position before fixing Z02.

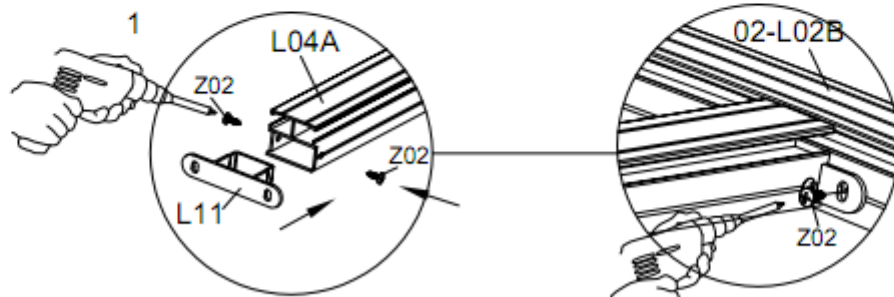



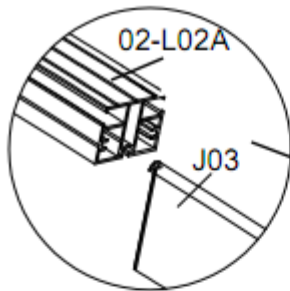

Insert L11 into L04A as shown, and fix it with L04A using Z02;

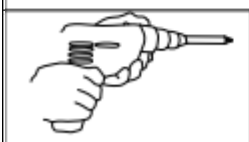
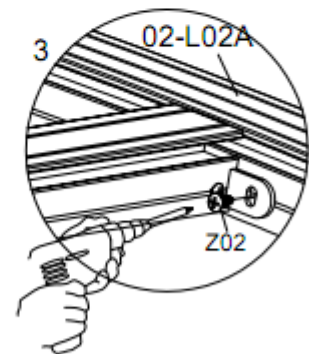
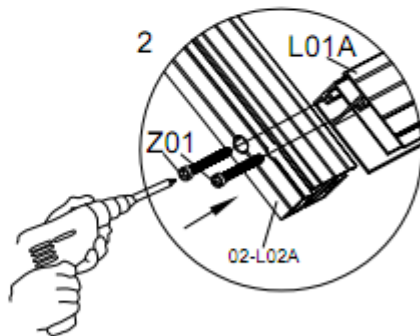
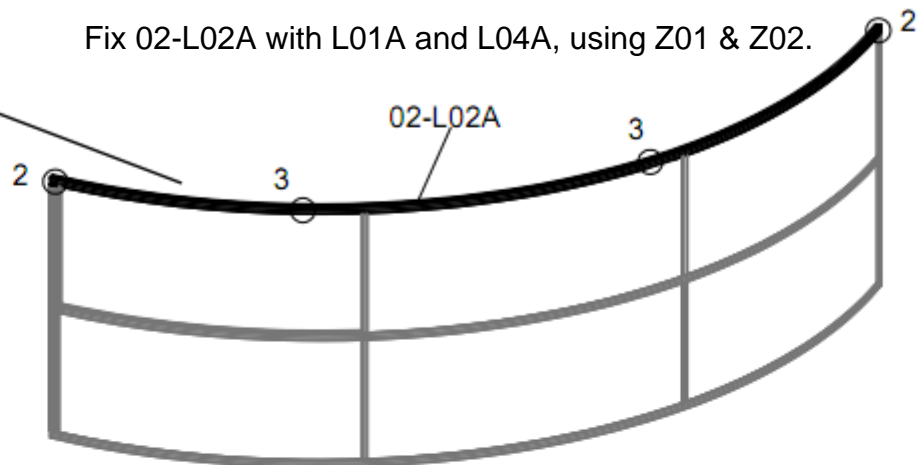

Slide Rubber J03 into the channel of 02-L02A.

Fix 02-L02A with L01A and L04A, using Z01 & Z02.



PART	NO	QTY
	CX	2
	J01	8
	Z03 M4.2X25	4

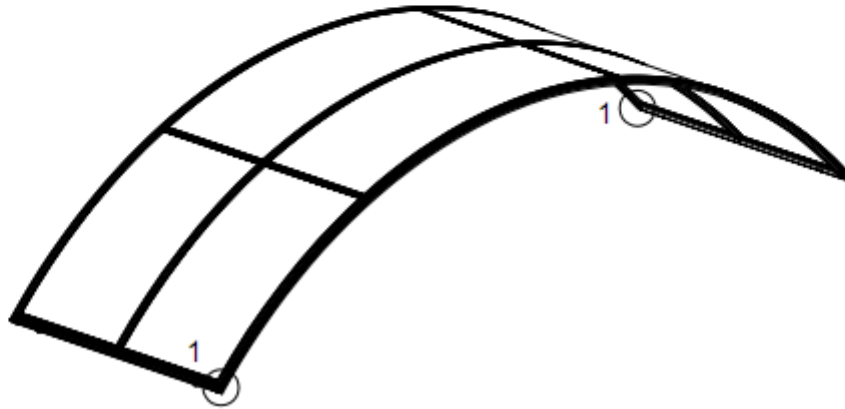



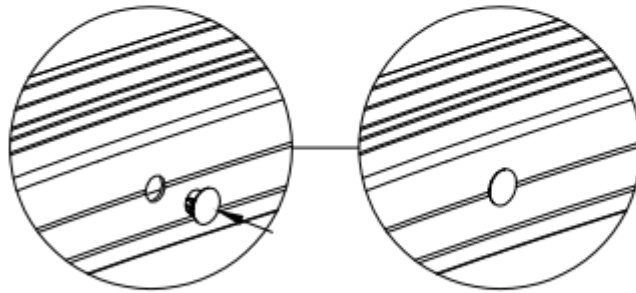
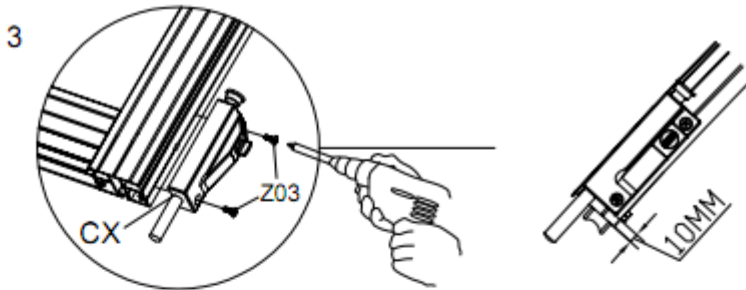



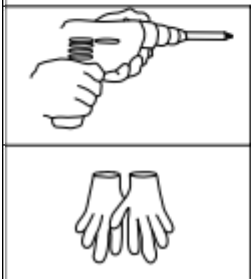









Fix CX (2PCS) onto 02-L02A 10MM away from the bottom, using Z03.



Cover all the holes with J01











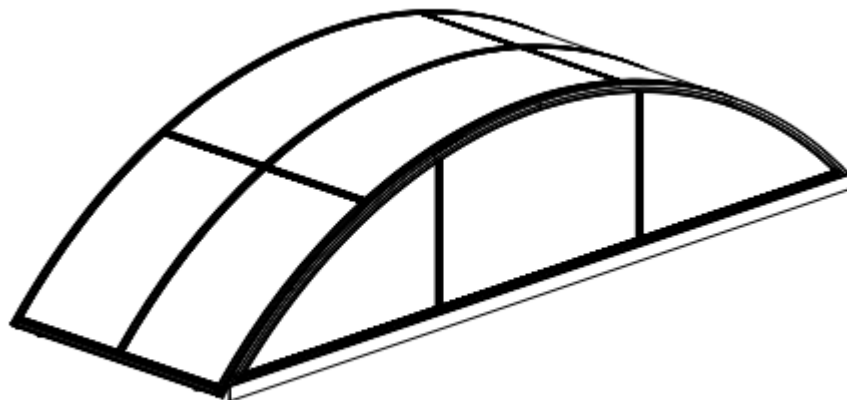

PART	NO	QTY
	L01A	2
	04-L02A	1
	04-L02B	1
	L04A	4
	L08B	1
	L11	8
	K3-1	1

PART	NO	QTY
	CX	1
	J01	12
	HL	6
	S01 M6X35	6
	M01	6
	M02	6
	Z01 M6X60	12
	Z02 M4X16	37
	Z03 M4.2X25	2

PART	NO	QTY
	Y3	6

K3



PART	NO	QTY
	L01A	2
	K3-1	1
	L08B	1
	HL	6
	M02	6
	S01 M6X35	6
	M01	6
	Z01 Ø6X60	4
	Z02 M4.2X16	5

Fix the wheels onto L01A (3PCS), using S01 & M01.

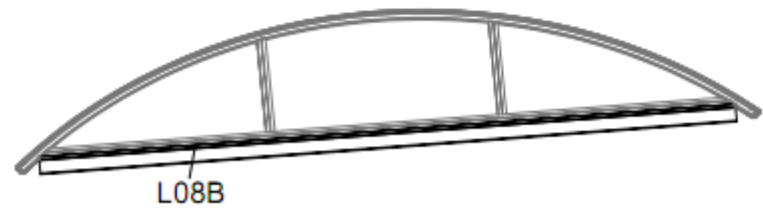
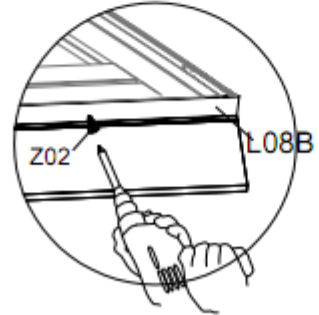
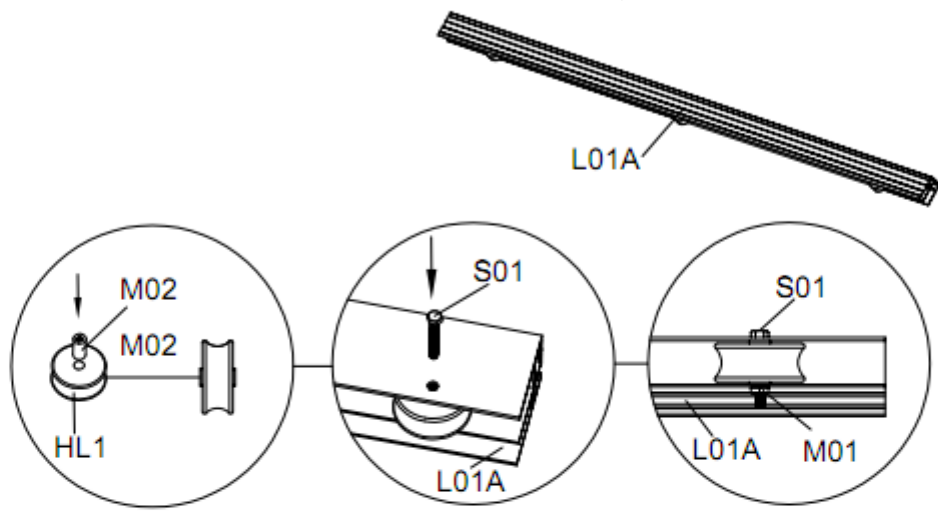

Fix L08B onto K3-1, using Z02.

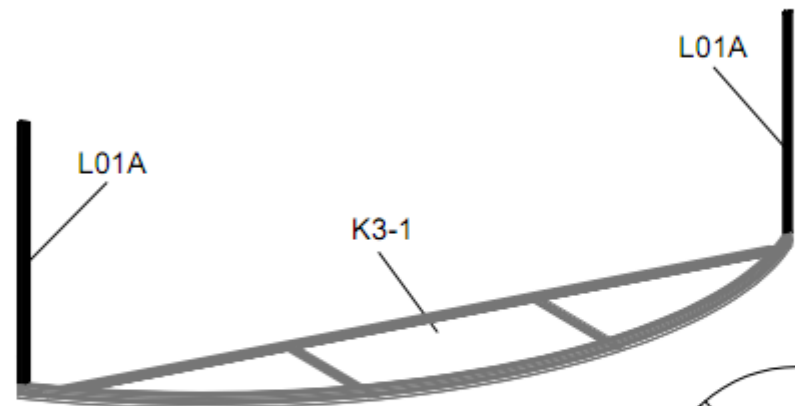

Fix L01A * 2PCS onto K3-1 using Z01.

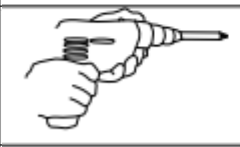
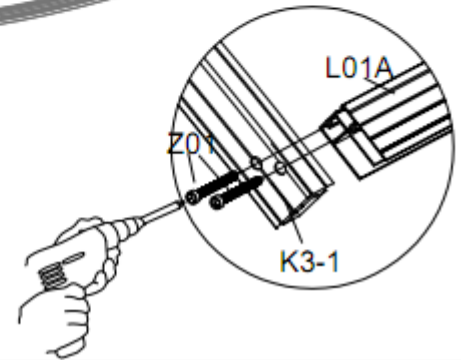

PART	NO	QTY
	L04A	2
	03-L02B	1
	L11	4
	Y3	3
	Z02	16
	M4X16	
	Z01	4
	M6X60	

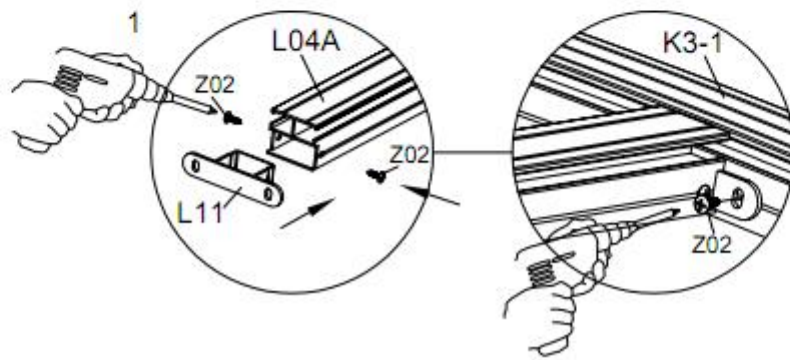
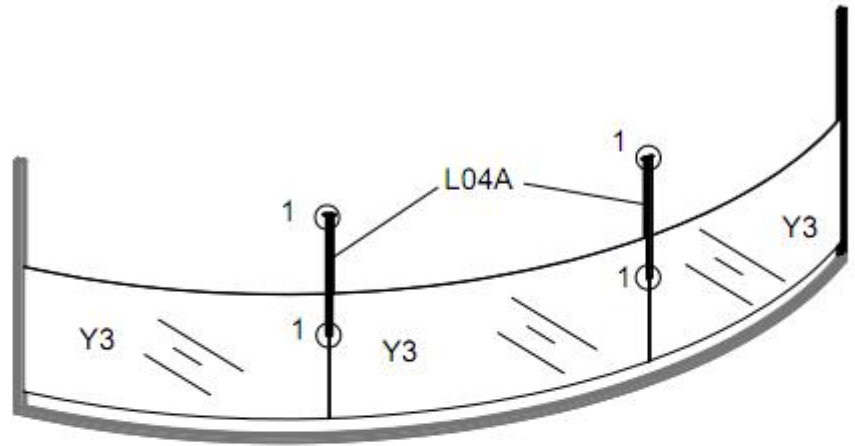





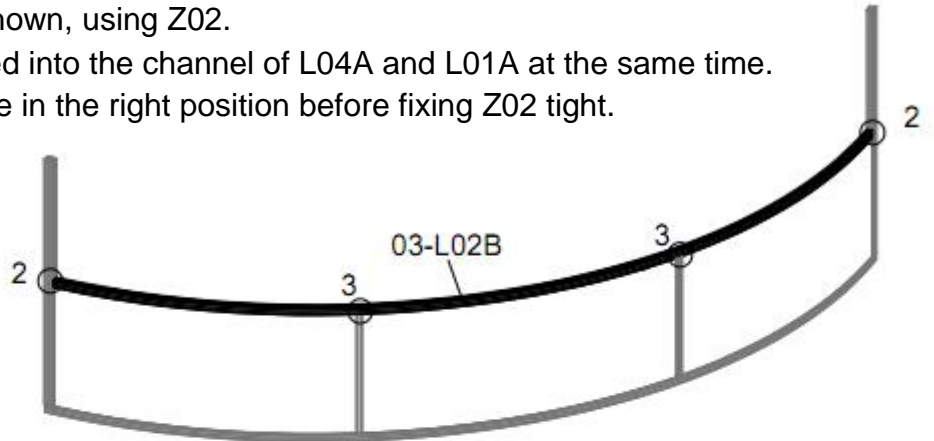

1. Insert L11 into L04A as shown, and fix it with L04A using Z02;
2. Fix L04A onto K3-1 as shown, using Z02.

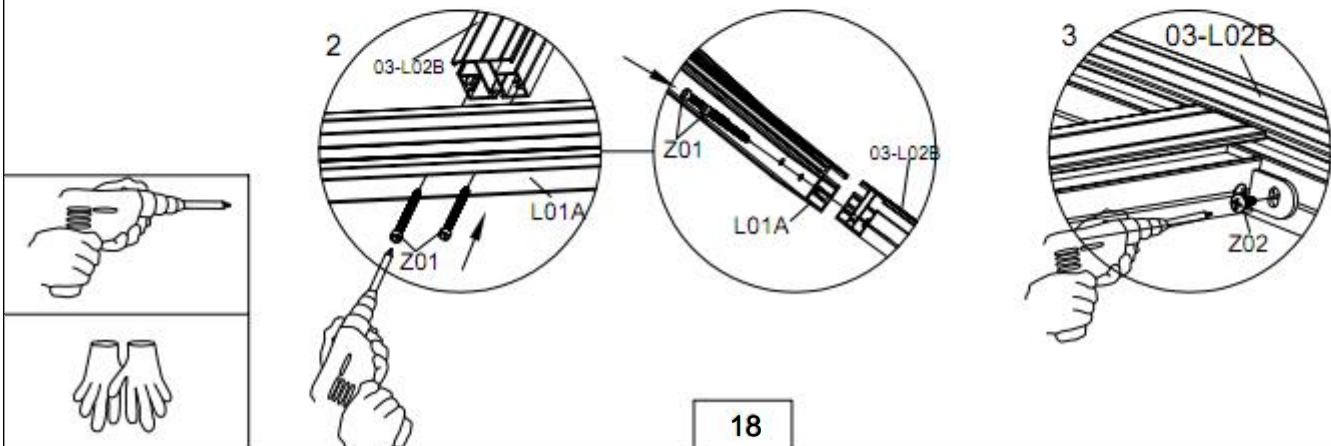
Attention: Y3 must be placed into the channel of L04A and L01A at the same time.
Make sure all the panels are in the right position before fixing Z02 tight.



Fix 03-L02B with L01A and L04A, using Z01 & Z02.



PART	NO	QTY
	03-L02A	1
	L04A	2
	L11	4
	Y3	3
	Z02	16
	M4X16	
	Z01	4
	M6X60	

Fix L04A onto 03-L02B as shown, using Z02.

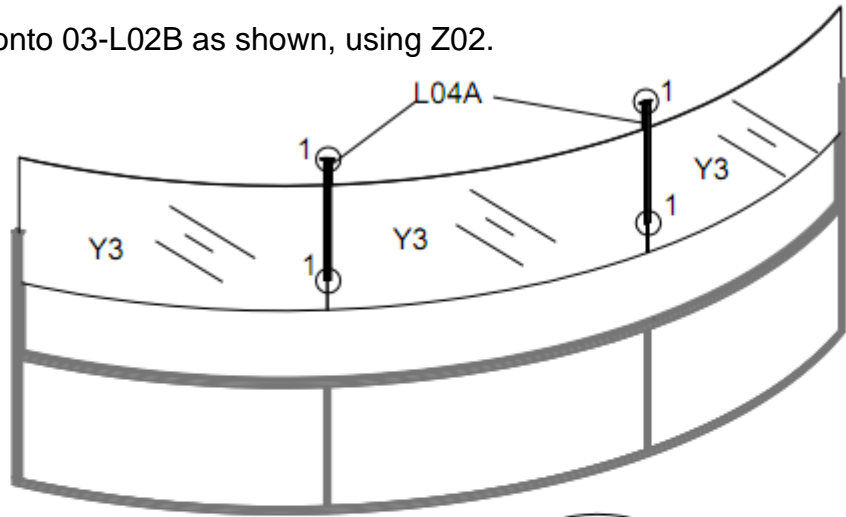

Attention:

Y3 must be placed into the channel of L04A/L01A at the same time. Make sure all the panels are in the right position before fixing Z02.

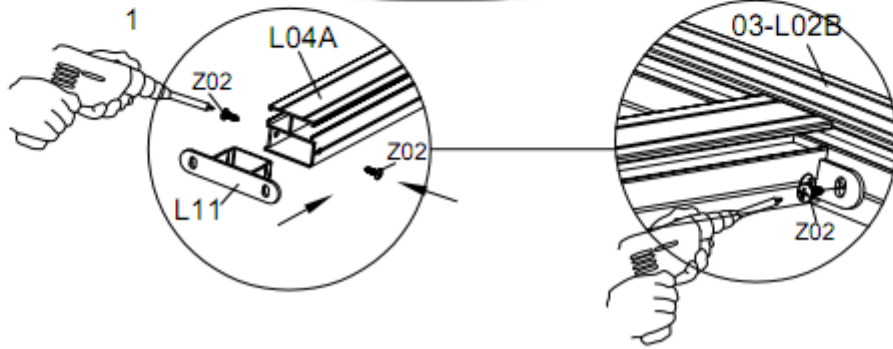

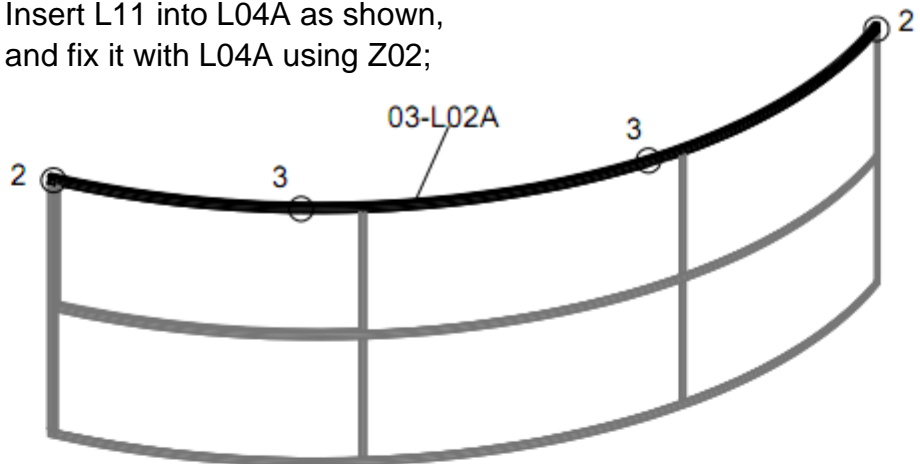

Insert L11 into L04A as shown, and fix it with L04A using Z02;

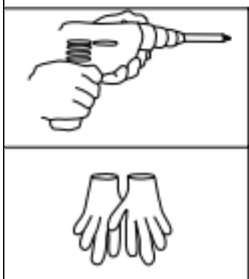
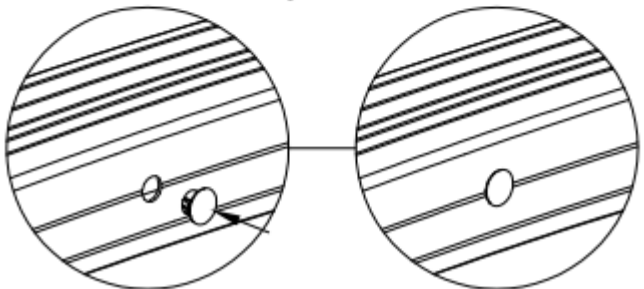

Fix 03-L02A with L01A and L04A, using Z01 & Z02.



Cover all the holes with J01

PART	NO	QTY
	CX	1
	J01	12
	Z03 M4.2X25	2

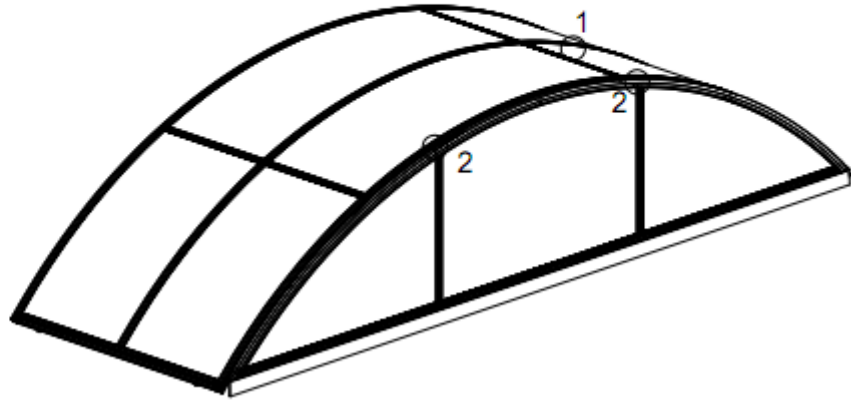

Fix CX onto 03-L02A 10MM away from the bottom, using Z03.

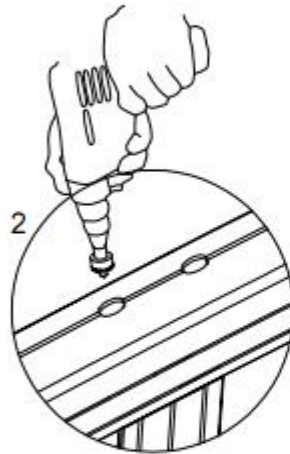
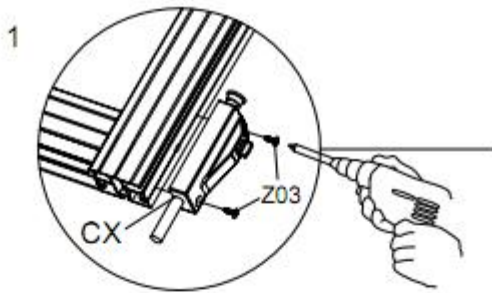



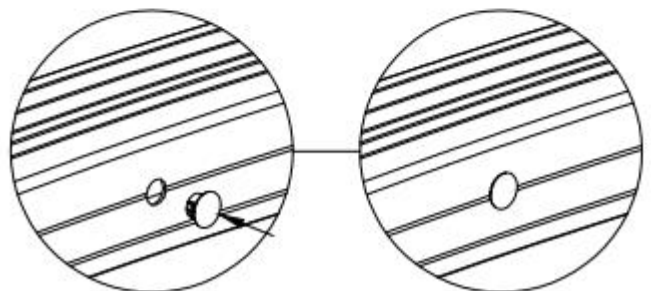

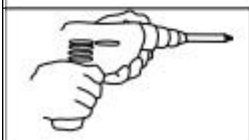

Widen the holes into Dia 14mm, using a reamer and a power screwdriver.



Cover all the holes with J01



PART	NO	QTY
	L06A	12
	L12	6
	L13	4
	J01	60
	J02	60
	Z01	60
	M6X60	
	Z02	24
	M4.2X16	

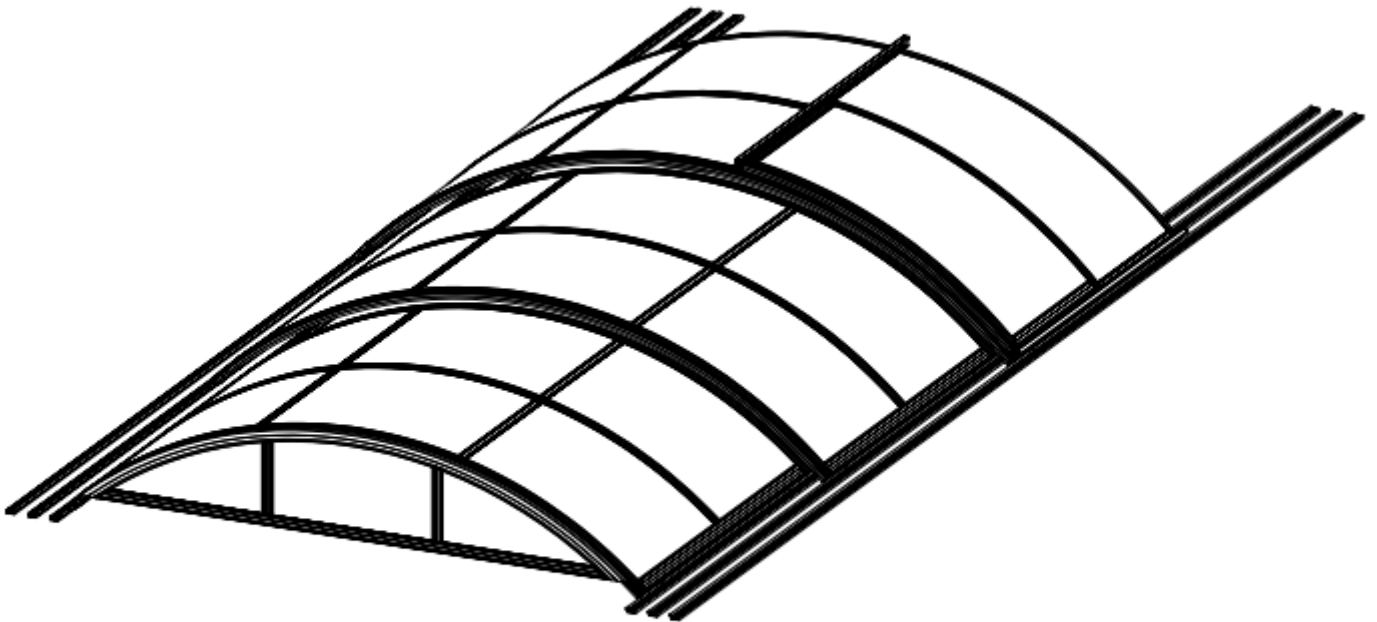

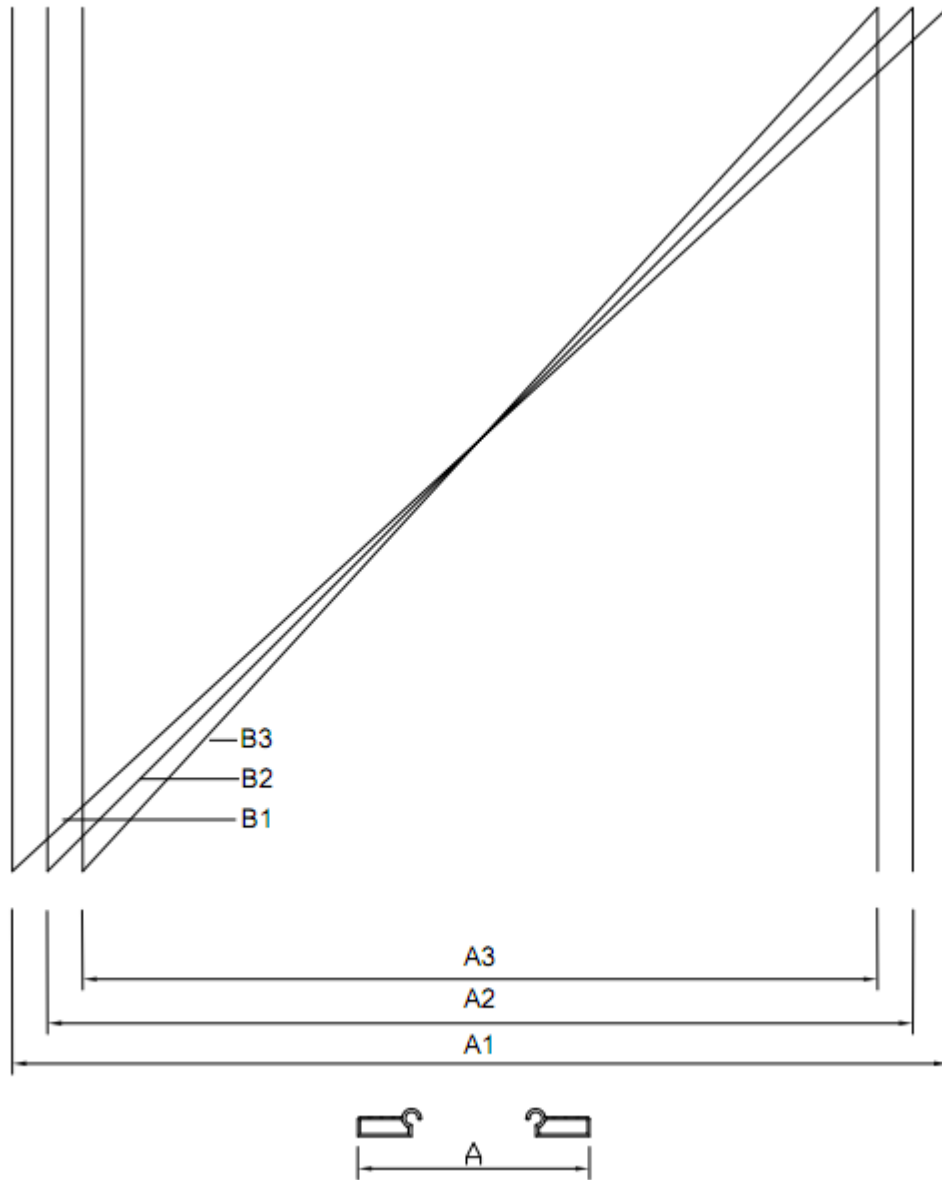

MM \ NO.	1	2	3
A (MM)	3906	3654	3402
B (MM)	9355	9252	9156

Small differences in the measurement are allowed in the actual installation

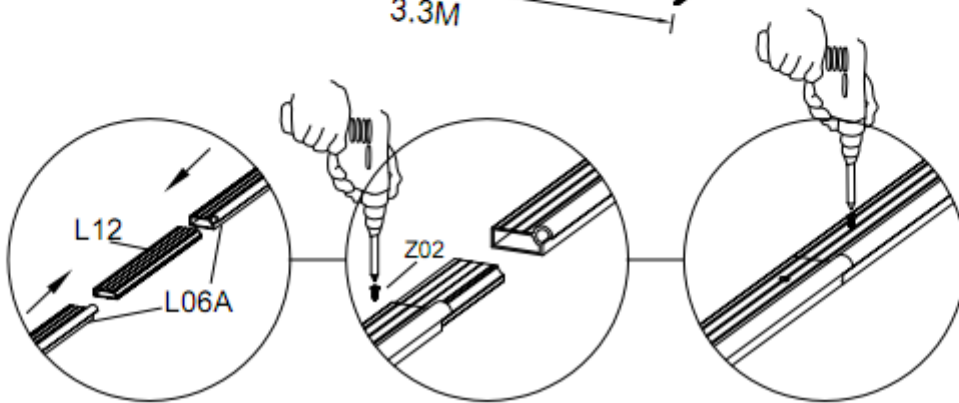
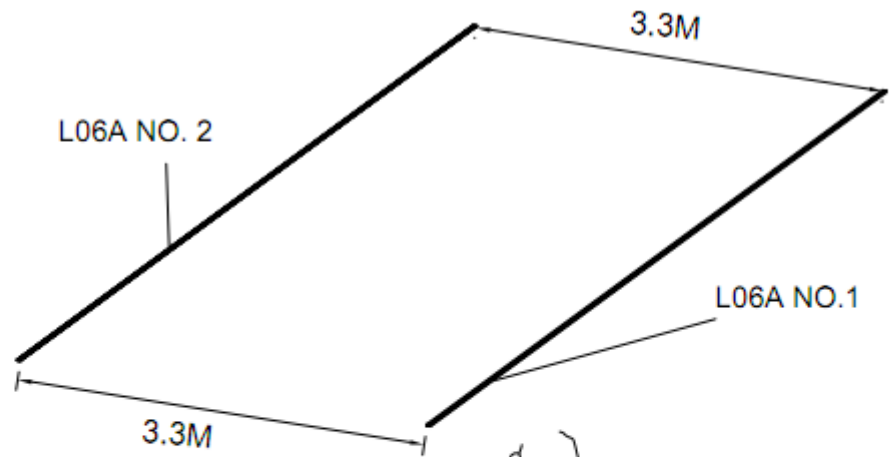

Join 2 pcs of L06A as a longer one by inserting L12 into two ends, and fix them with Z02.

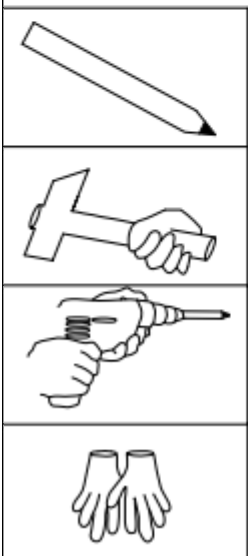
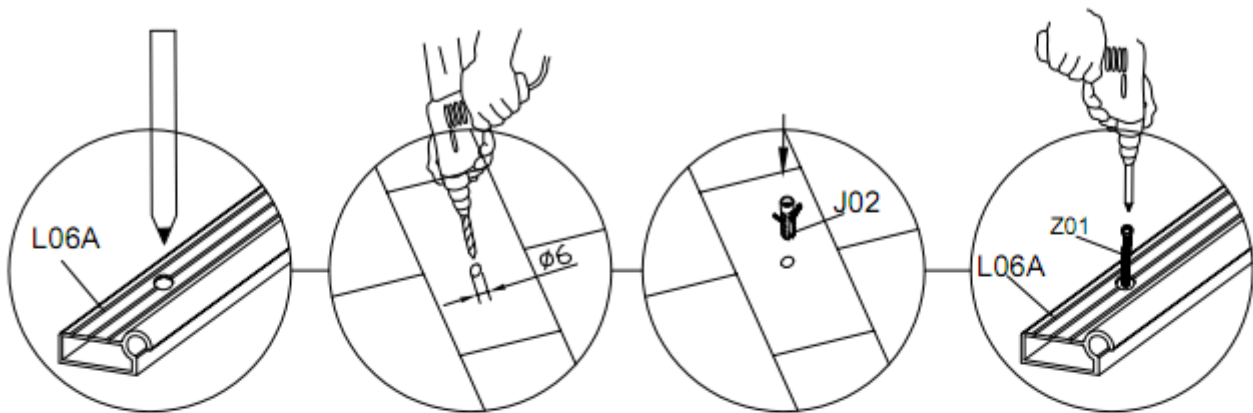

1. Lay down 2 longer L06A at the right distance as shown above.
2. Make pencil marks through the holes on one L06A, and then drill holes Dia 6MM on the ground.
3. Tap J02 into the holes and fix the first L06A onto the ground through the holes, using Z01.
4. Make sure The second L06A inner distance is 3300MM and outer distance is 3402MM away from the first L06A.
5. Do not fix the second L06A onto the ground until K3 is moving smoothly on the two tracks.

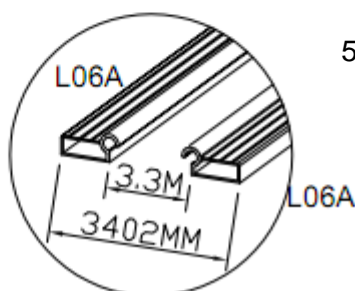

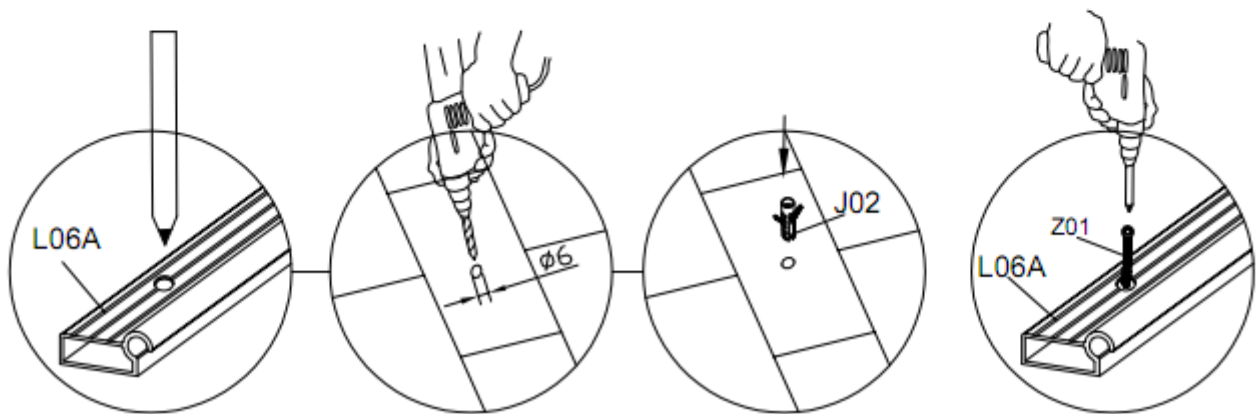
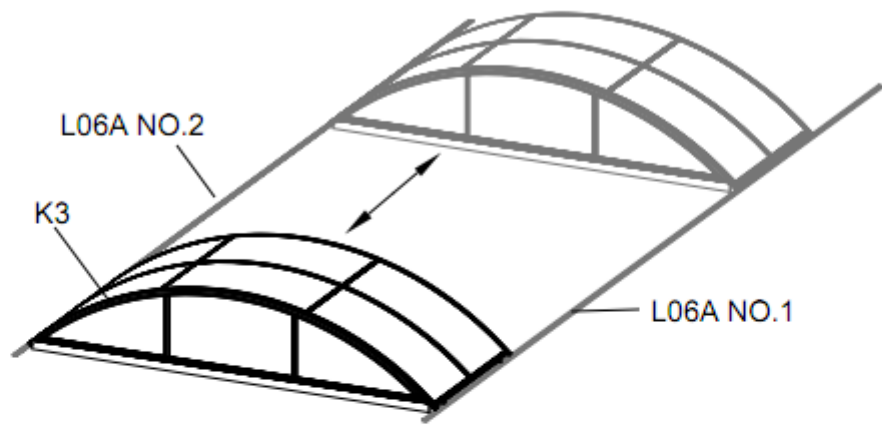

1. Put K3 into the two tracks and adjust the L06A NO. 2 until K3 is moving smoothly.
2. Make pencil marks on the ground through the holes on L06A, and then drill holes Dia 6MM on the ground.
3. Tap J02 into the holes, and fix the L06A NO.2 onto the ground through the holes, using Z01.

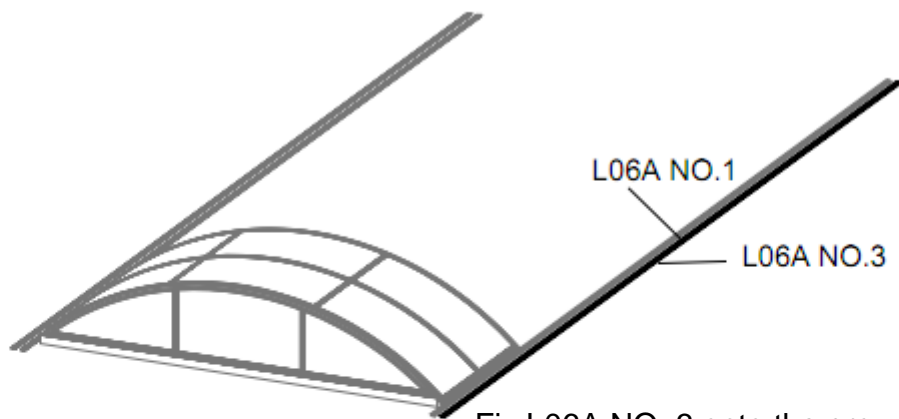

Fix L06A NO. 3 onto the ground as above, 126MM away from the L06A NO.1, see below.

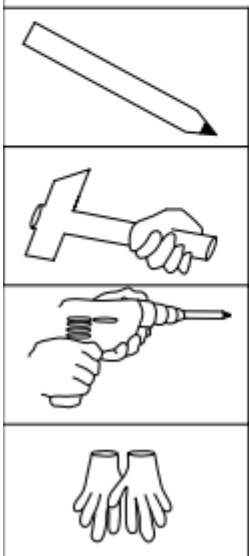
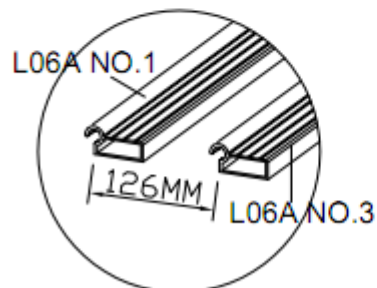

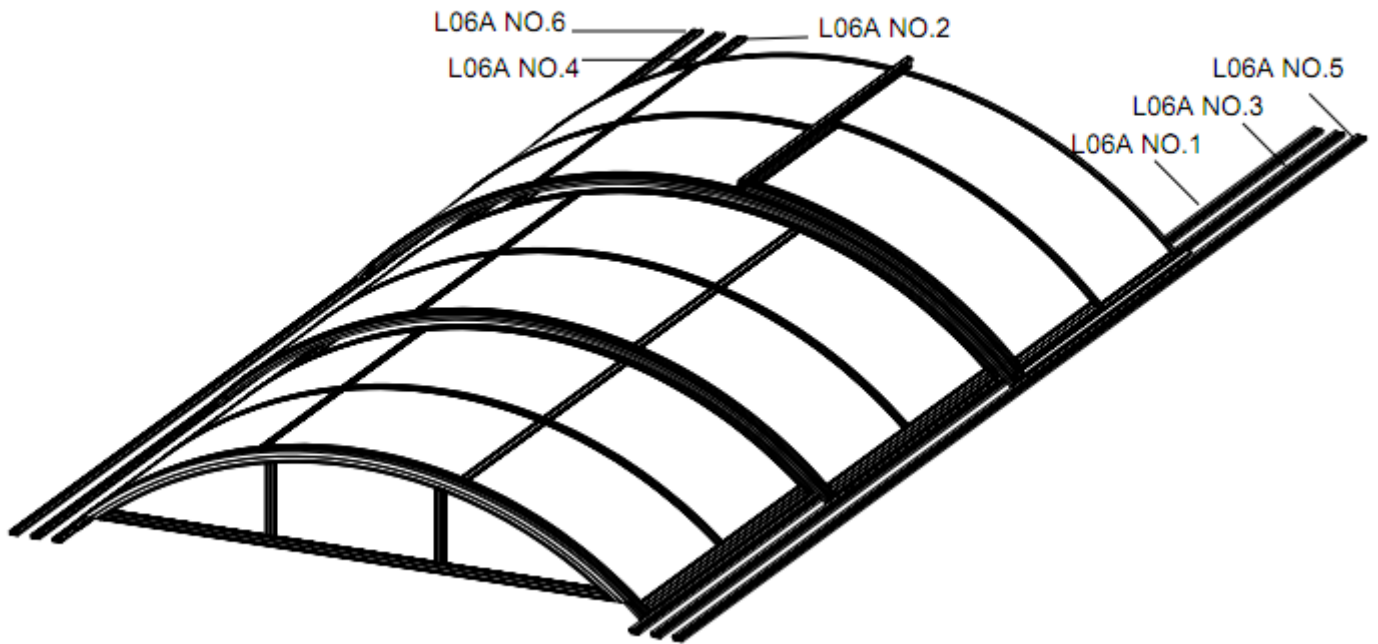

Fix the rest L06A in order the same way as above.
 Make sure all the covers must move smoothly
 before fixing the screws tight.

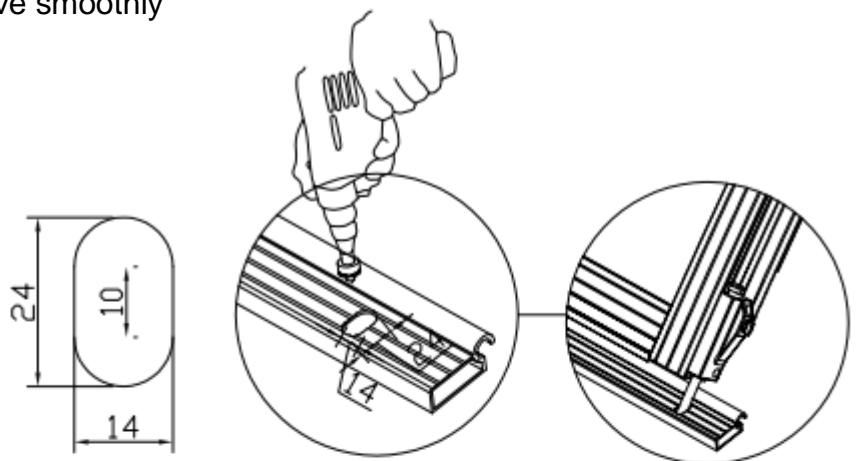

Drill 4 oval holes (14*24mm) on L06A corresponded to the 4 latches (CX).
 This will help you lock up the swimming pool cover when you close it.

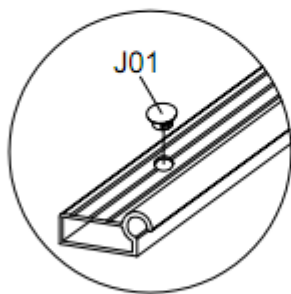

Cover all the holes on L06A by J01

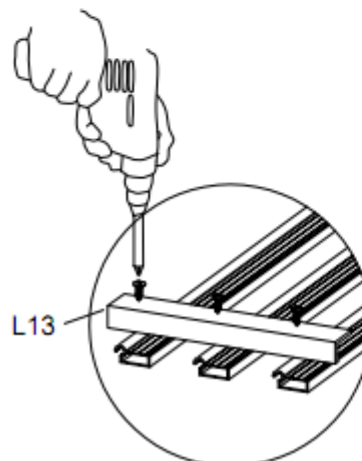

Finally, fix L13 (4PCS)
 at the ends of L06A,
 using Z02.

