

LED SPOT

LED SPOT 1x3W

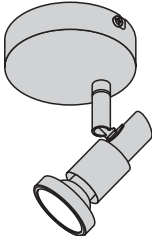

LED SPOT 4x3W

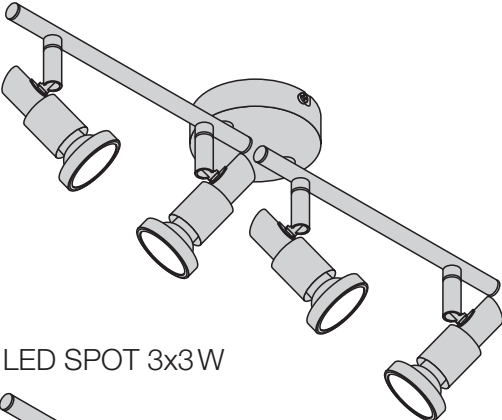

LED SPOT 2x3W

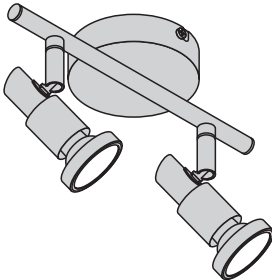

LED SPOT 3x3W

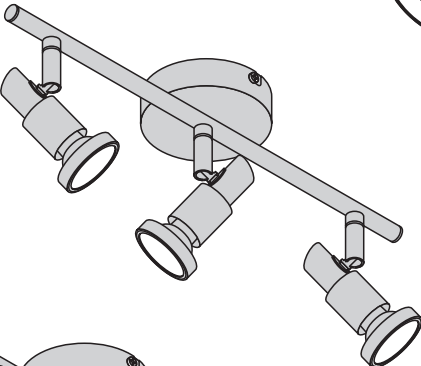

LED SPOT 6x3W

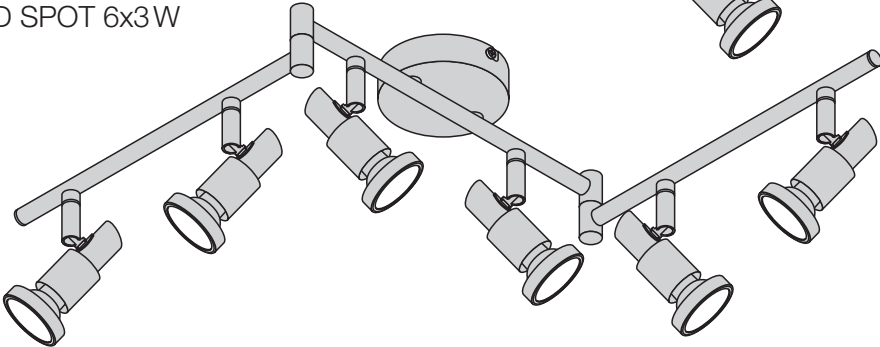

LED SPOT

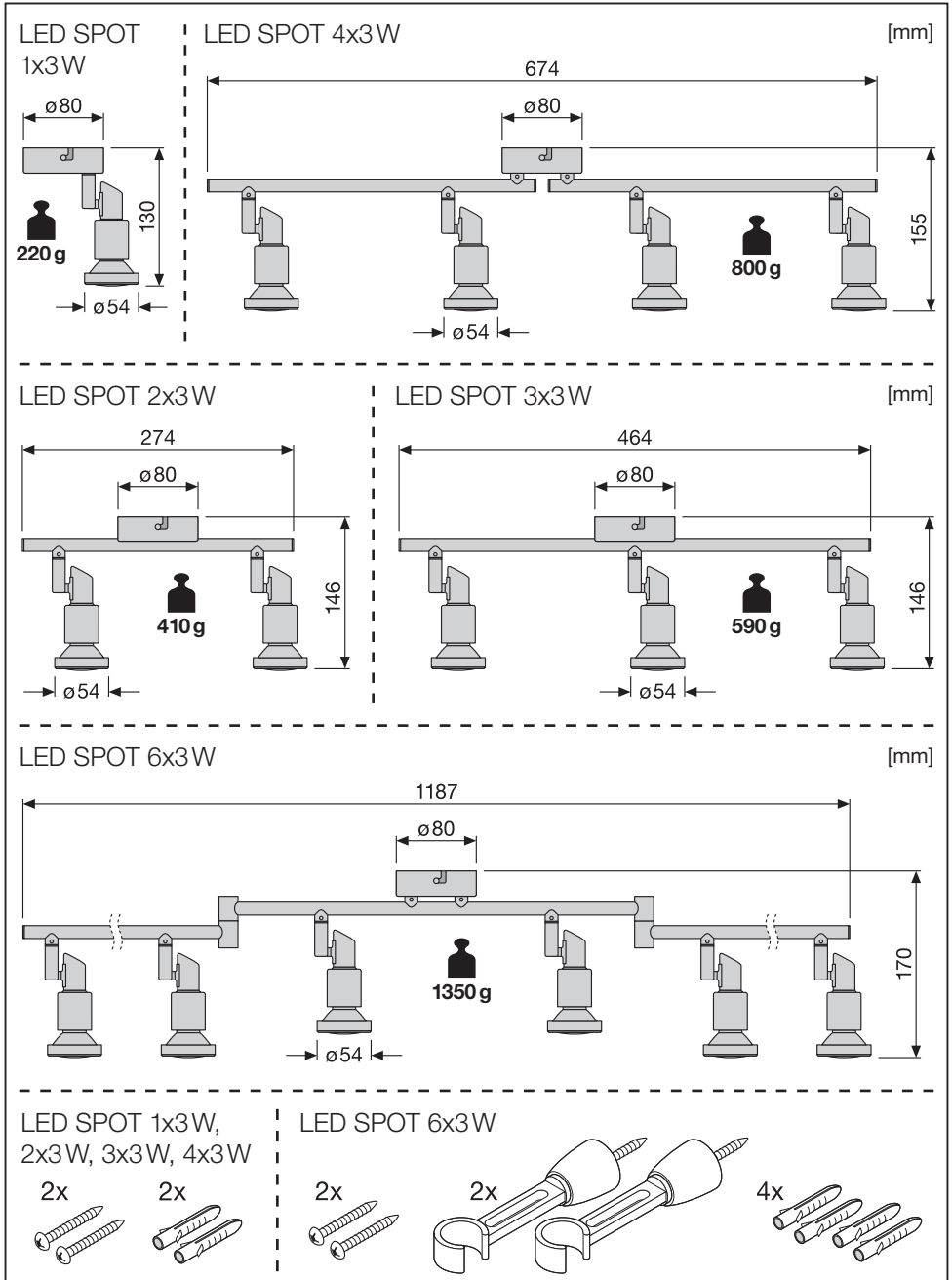

LED SPOT

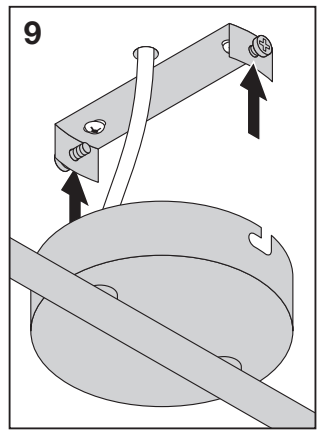
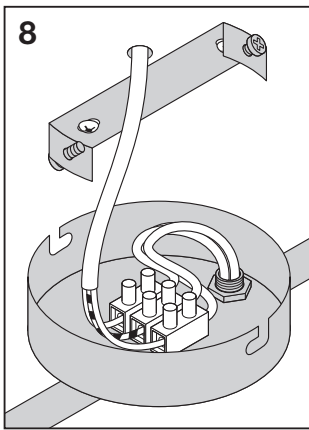
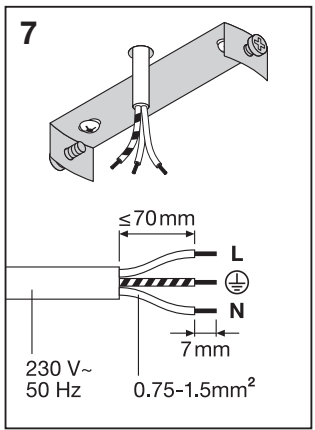
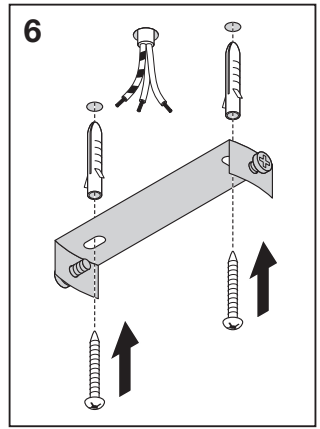
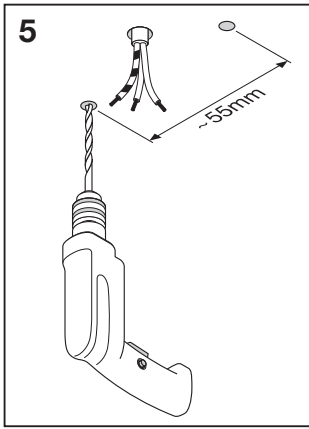
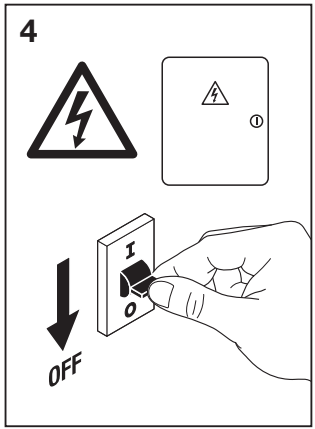
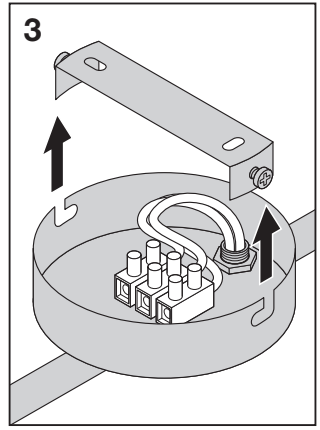
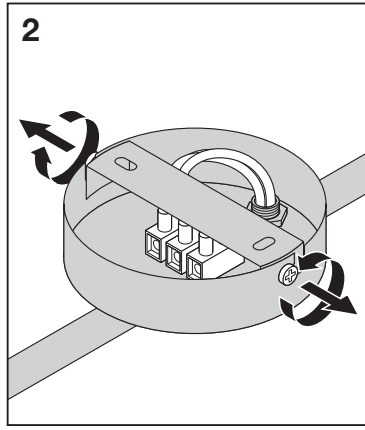
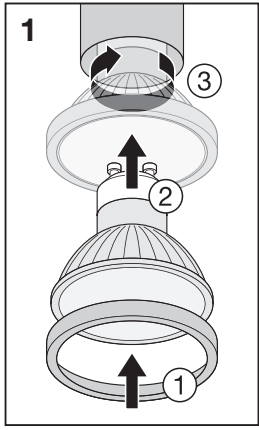

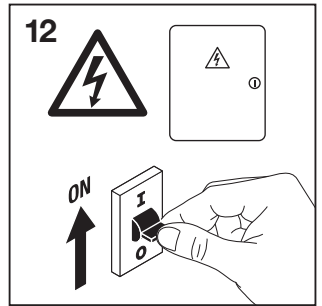
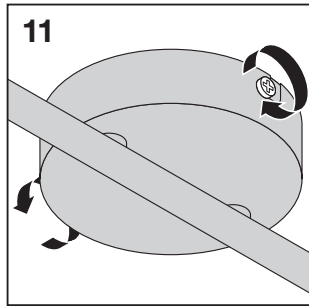
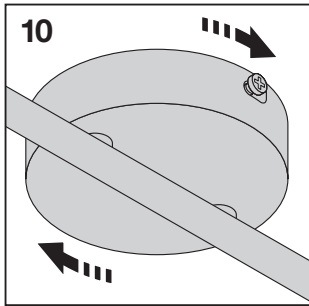

LED SPOT 6x3W

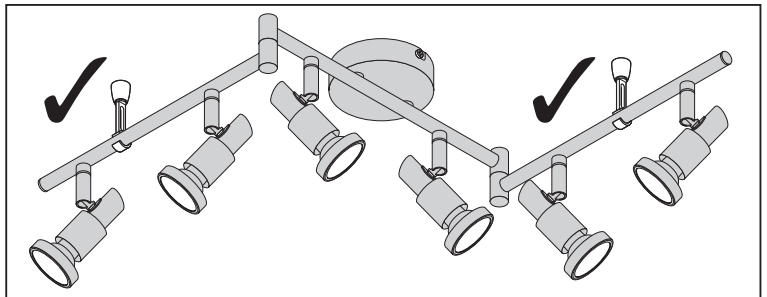
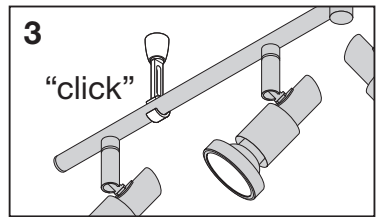
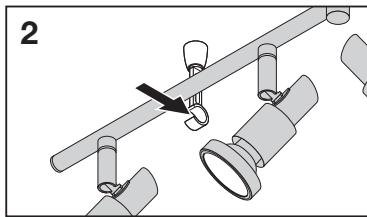
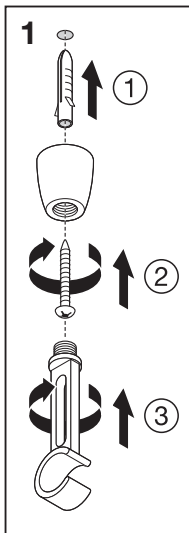
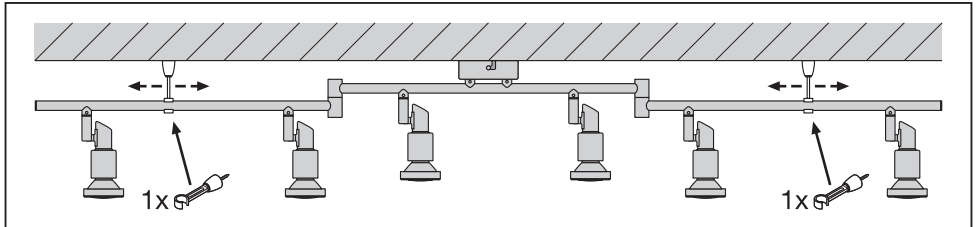

Ⓢ Netzanschluss bitte nach den länderspezifischen Errichtungsbestimmungen tätigen. Ⓢ Connect to the power supply in accordance with national regulations. Ⓢ Connexion à l'alimentation conformément aux normes en vigueur. Ⓢ Effettuare l'allacciamento alla rete secondo le norme di installazione vigenti nel paese d'utilizzo. Ⓢ La conexión a red debe de realizarse siguiendo las normas específicas de cada países. Ⓢ Ligar à fonte de alimentação, de acordo com a regulamentação nacional. Ⓢ Η σύνδεση με την παροχή ρεύματος να γίνεται σύμφωνα με τις εθνικές προδιαγραφές. Ⓢ Aansluiten op het lichtnet, conform de nationale regelgeving. Ⓢ Nätaanslutning skall ske enligt nationella bestämmelser. Ⓢ Kytkentä verkkoon kansallisten ohjeiden mukaan. Ⓢ Koble til strømforsyningen i henhold til nasjonale bestemmelser. Ⓢ Nettislutning jf. landespecificke bestemmelser. Ⓢ Припоєнє к сїтовому напєдї дїє пїратньою нєроднїх порєт. Ⓢ Выполнїть подкљученїє к сєтї в сѳветствїи с прїнєтїями в дєннѳи странѳе прївлєнїем пїравїлїи монєжї. Ⓢ Csatlakoztass a társulésbe a helyi előírásoknak megfelelően. Ⓢ Zasilanie należy polączyć zgodnie z wymaganiami odpowiedniej norm. Ⓢ Zapojeite do el. privodu podľa predpísaných noriem. Ⓢ Priključitev na omrežje opravite v skladu z veljavnimi nacionalnimi predpisi. Ⓢ Šebeke bağlantsını lütfen ülkeye özgü kurulum kuralları çerçevesinde yapınız. Ⓢ Molimo izvršite mrežni priključak prema specifičnim nacionalnim odredbama o njegovom izvršenju. Ⓢ Conectati la sursa de tensiune conform prevederilor din țara în care vă aflați. Ⓢ Свързването към захранващото напрежение да се направи в съответствие с местните наредби. Ⓢ Elektrivõrkku ühendamiseks jälgida kohalikele elektripaigaldistele ehitamise eeskirju. Ⓢ Prijuokite prie maitinimo šaltinio atsižvelgiant į nustatytus valstybinius reikalavimus. Ⓢ Pievienojiet barošanas kabell saskaņā ar nacionālajiem standartiem. Ⓢ Molimo da mrežni priključak provedete prema specifičnim nacionalnim odredbama o njegovom provedenju. Ⓢ Підключення до електромережі здійснювати у відповідності до монтажних норм кожної окремої країни.

C10449057
G10606669
24.06.16



LEDVANCE GmbH
Steinerne Furt 62
86167 Augsburg, Germany
www.ledvance.com