



Asennus Ohjeet
Monterningsanvisning

Nature 6'x10' Hybrid

310x185x209cm / 122"x72³/₄"x82¹/₄"

Base: 305 x185cm / 120"x72³/₄"

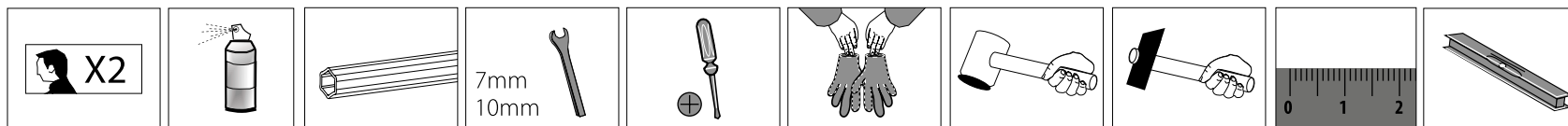
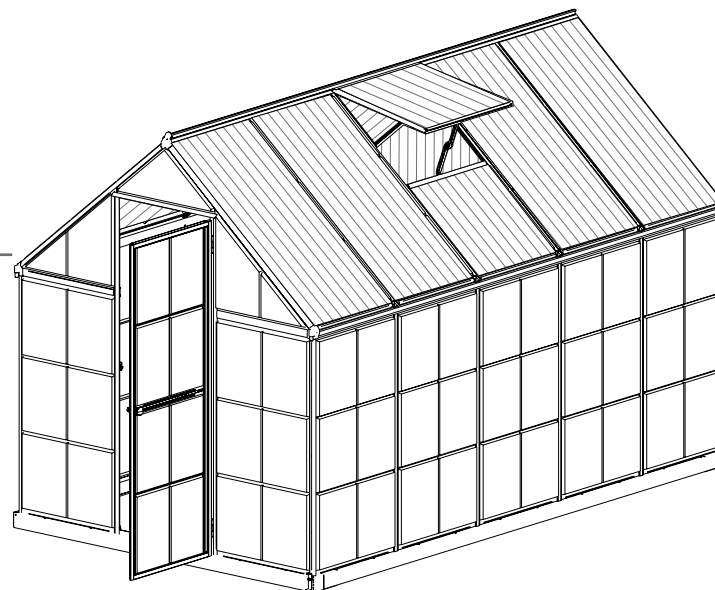

Finnish_Swedish_71315

NEUVONTA :

040-822 3282 / 09-6866 720

tuki@horisontenterprises.fi

www.palramapplications.com



7 290103 110727 >

TÄRKEÄÄ

Lue ensin huolellisesti nämä ohjeet ennen kasvihuoneen asentamista ..
Säilytä nämä ohjeet turvassa vastaisuuden varalta

⇒ Asiakas palvelu

Jos tarvitset apua / neuvoja asennukseen tai osien vaihtoon – käänny meidän kotisivujen ,sähköpostin puoleen tai soita jälkimarkkinointiimme (tiedot löytyvät kansilehdestä).

www.horizontenterprises.fi , tuki@horizontenterprises.fi ,
+358 40 822 32 82 / +358 9 68 66 720

Lisäinformaatiota löydät valmistajan sivuilta www.palramapplications.com

⇒ Turvallisuus ohje

- Ensisijaisen tärkeätä on noudattaa asennusohjeen järjestystä ja ohjeita – älä jätä mitään tekemättä.
- Suosittelemme suojakäsineiden käyttöä asennustyössä.
- Käytä aina tukevia kenkiä ja suojalaseja työskennellessäsi metallituotteiden kanssa.
- Jos käytät tikkaita , apuvälineitä , akkuporakonetta - varmista aina myös työkalu valmistajan käyttöohjeet.
- Älä kosketa sähköjohtoja tai lähteitä metallisten esineiden kanssa.
- Älä yritä pystyttää / asentaa kasvihuonetta tuulisella , sateisella tai huonolla säällä.
- Hävitä huolellisesti kaikki muoviset pakkaustuotteet ja varmista ettei ne pääse pienten lasten lähetyville.
- Pidä lapset loitolla työskentely alueelta ja pidä myös alue aina siistinä.
- Älä työnnä tai nojaa kasvihuoneen rakenteisiin asennusvaiheen aikana.
- Valitse huolella kasvihuoneen sijainti , siten ettei se ole alttiina kovalle tuulelle tai ylimääräisille lumikuormille.
- Älä yritä asentaa tätä kasvihuonetta puolikuntoisena , väsyneenä , päihteiden taikka lääkityksen vaikutuksen alaisena.
- Kuumat tuotteet kuten grillit , polttotyökalut , terassilämmittimet tulee säilöä mualla kuin kasvihuoneessa. Varmista että maahankiinnitys on turvallista ja ettei maaperässä ole putkia tai sähköjohtoja.

Tämä tuote on suunniteltu ainoastaan kasvihuoneeksi.

⇒ Huolto & ylläpito

Kun kasvihuoneesi kaipaa pesua & puhdistusta, käytä ainoastaan mietoa saippuavettä ja huuhtelee runsaalla kylmällä vedellä. ÄLÄ KÄYTÄ acetoonia, liuottimia tai muita voimakkaita puhdistusaineita – ei myöskään mäntyöljypohjaisia aineita. On suositeltavaa että asennuksen kunto tarkistetaan säännöllisesti , kattolevyt > kiinnikkeet (muoviset osat 329 & profiilit 981) ovat paikoillaan.

⇒ Työkalut & Välineet

- Mittanauha
- Työkäsineet
- Liukastusaine
- Ristipää ruuvimeisseli
- Porrasaskelma tikkaat
- Poraus terät
- Iso kumivasara
- Sakset
- Kiintoavain, 7mm ja 10mm

- T001 (valmistajan tekemä erikoistyökalu , mukana toimituksessa)

**⇒ Ennen Asennustyötä**

Tämä on moniosainen asennustyö joka hoituu parhaiten min. kahden asentajan toimesta. Varaa aikaa kasvihuoneen pystytykselle vähintään puoli päivää. Ennen sitä tulee kasvihuoneen perusta valmistaa huolella valittuun paikkaan.

Varmista että perustan mitat vastaavat kasvihuoneen sokkelin mittoja.

Kasvihuoneen sijainnin valinnassa tulee huomioida seuraavat seikat , perustan tulee olla suora, mielellään aurinkoinen

sijainti poissa puiden oksien läheisyydestä.

Samoin sijainnin tulisi olla paikassa jossa sen päälle ei pääse putoamaan lunta tai jäätä toisesta rakennuksesta. Kovin tuulista sijaintia tulisi myös välttää. Kasvihuone tulee kiinnittää tukevasti perustaan metallisokkelilla. Metallisokkelin alareunassa on valmiit kiinnityspisteet. Aloita tyhjentämällä pakkaukset ja varmistamalla että kaikki tarvittavat nimetyt osat löytyvät – tarkista koontiluettelosta tuotteet & määrät.

Pidä osat lähetyilläsi työalueella. Pidä pienet osat (ruuvit & mutterit j.n.e.) astiassa, etteivät ne pääse hukkumaan.

Varmistaaksenne osien oikeellisuuden ovat osat numeroidut, kaikki osat tulee asentaa valmiiseen huoneeseen. Joihinkin profiileihin saattaa jäädä käyttämättömiä ruuvien reikiä /aukkoja valmistusteknisistä syistä.

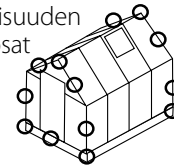
**⇒ Asennuksen Yhteydessä**

Noudata asennusohjeen työjärjestystä.

Vaihe 1: Varmista että perusta on suorassa ja suorakaiteen muotoinen ristimittauksella.

Vaihe 4: Osat A994, A995 kuuluvat kasvihuoneen takaosaan. Asentamalla em osat päätät oviaukon puolen, kts kohta 8.

Vaiheet 7, 10, 13: Sivutuen A256 ovaalireikä tulee asentaa alas .

Oven asennus (Vaiheet 8, 44-49)

Oven aukeamissuunta voidaan vapaasti määrittää. Tämä ohje etenee oikeanpuoleisen avauksen osalta .

Vaihe 8: määrittää avaussuunnan
Profiili 987 on saranapuolen määrittävä puoli

Vaiheet 44-49: Oven asennus etenee edellä tehdyn päätöksen pohjalta.

Vaiheet 30-32: Päätä valmiiksi kattoluukun sijainti. Kattoluukun voi asentaa kohdan 30 ohjeen sijainnin mukaan mielellään siten että kattoluukun suuntaus ei olisi aurinkoon päin (etelä – lounas).

Vaihe 51: Varmista kasvihuoneen jäämäkkä kiinnitys perustaan heti asennusvaiheiden jälkeen.

Ruuvit 411 ja mutterit 412 ovat yleisesti käytössä koko kasvihuoneen osalta.

- Ruuvit 411 asennetaan ulko sisäänpäin ja mutterit 412 kiristetään sisäpuolelta
- Älä kiristä tiukkaan alkuvaiheessa ruuveja ja muttereita(411 & 412) sormitkiristystä enempää.
- Tarvitset ruuvien suomaa säätöväljyyttä levykiinnityksiin asti. Lopussa kaikki liitokset tulee kiristää työkaluilla tiukasti kiinni. Joissain työvaiheissa tulet tarvitsemaan osien paikallaan pysymisen vuoksi hiukan suurempaa kiristystä.

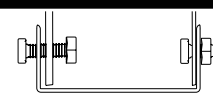

Viktigt

PLäs noggrant igenom dessa instruktioner innan ni börjar montera växthuset.
Spara instruktionerna för möjligt efterhanda behov.

⇒ Kund Service

För rådgivning av montering eller byte av delar – vänligen kontakta våra hemsidor e-mail eller telefon hjälp (info på första sidan).

www.horizontenterprises.fi , tuki@horizontenterprises.fi ,
+358 40 822 32 82 / +358 9 68 66 720

Tilläggs information hittar du på producentens hemsida: www.palamapplications.com

⇒ Säkerhetsföreskrifter

- Följ monteringsstegen i den ordning som anvisas i instruktionerna, utelämnade eller hoppa inte över steg.
- Vi rekommenderar att handskar , skor och skyddsglasögon alltid används då man arbetar med metal profiler.
- Vid användning av stege , redskap och bormaskin , följ även producenternas föreskrifter.
- Var noga med att inte komma i kontakt med elkablar då metal profiler hanteras.
- Försök inte att montera växthuset i dåligt , blåsigtt väder eller i regn.
- Ta väl hand om all plastpåsar och se till att dom är utom räckhåll för barn.
- Låt inte barn vistas på monteringsplatsen och håll omgivningen snygg.
- Luta eller tryck inte på växthuset under montering.
- Välj omsorgsfullt platsen för växthuset så att huset inte påfrästs av kraftig vind eller extra snö.
- Försök inte montera växthuset om du känner dig , är påverkad av mediciner eller alkohol eller om du har anlag för yrsel.
- Heta föremål som en nyligen använd grill, blåslampa eller dylikt får inte förvaras i växthuset . Försäkra att det inte finns några dolda rör eller kablar i marken innan du slår ner metallfästena för att förankra växthuset.
- Denna product är avsedd för att användas som växthus endast.

⇒ Underhåll & skötsel

När växthuset behöver rengöras skall du använda ett mildt rengöringsmedel och skölja rikligt med kallt & rent vatten.

Använd inte acetone, slipande rengöringsmedel eller andra specialmedel för att rengöra panelerna. Vi rekommenderar att man tidvis kontrollerar takpanelernas fäste (+ plastiska fästen 329 & profiler 981) och försäkrar deras rätt position.

⇒ Verktyg & redskap

- Måttband
- Handskar
- Silikon spray
- Krysskrummejsel
- Stege
- Drill bit
- Hammare (stor)
- Sax
- Skiftnyckel
- T001 verktyg (incl. förpackningen)

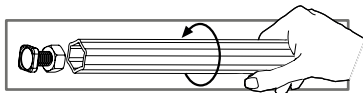

⇒ Före montering

Detta är ett mångfaldigt monteringsarbete som bäst utförs av min. två personer. Reservera åtminstone en halv dag

för monterings processen. Före monteringen bör grunden vara väljord på den valda platsen. Försäkra att grundens mått passar ihop med växthusets sokkelns mått.

Vid val av växthusets positionering bör följande saker iakttagas , grunder bör vara rak , hållst solig plats borta ifrån

avskuggande träd och gränar.Samtidigt border överlopps is och snökast från träd ,gränar eller byggnader uteslutats.

Även vindiga platser bör undvikas. Växthuset bör stadigt fästas i grunden med husets metallsockel. Metallsockeln har färdiga fäst positioner. Börja med att tömma förpackningen och försäkra att alla väsentliga och benämnda delar

är tillgängliga – kontrollera från innehållsförtäckningen att alla delar är rätt bemärkta och finns i rätt mängd.

Håll alla delar nära dig vid monteringen.

Förvara alla smådelar (skruvar & muttrar o.s.v.) i en skål , så att de inte tappas bort. Delarna är bemärkta med nummer för kännedom – alla delar bör assembleras. I några profiler kan fästen bli oanvända

p.g.a produktionstekniska grunder.

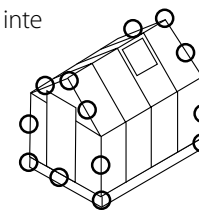

⇒ Under monteringen

Utför monteringsstegen i den ordning som anges i instruktionerna.

Steg 1: Försäkra att underlaget är plant och vågrätt samt diagonalt.

Steg 4: Delarna A994, A995 tillhör växthusets bakvägg. Vid montering av förenämnda delar bestämmer du dörr sidan, se punkt 8.

Stegen 7, 10, 13: Sidostödets A256 ovaalhåll bör monteras ner.

Montering av dörr (Stegen 8, 44-49)

Dörrens öppningriktning kan väljas. Denna instruktion följer höger öppningriktning.

Steg 8: bestämmer öppningsriktningen.

Profil 987 är gångjärns sidan.

Stegen 44-49: Dörrens assemblering följer vald riktning.

Stegen 30-32: Bestäm på förhand takluckans position. Takluckan kan installeras enligt punkt 30 men gärna Så att den inte riktas mot solen (söder – sydväst).

Steg 51: Försäkra ett stadigt fäste av basen i underlaget så fort som monteringen är färdig.

Skruvarna 411 och muttrarna 412 är universalt i användning för hela växthuset.

- Skruvarna 411 monteras utifrån innåt och muttrarna 412 spänns innifrån.
- Spänn inte skruvarna och muttrarna (411 & 412) för stramt. Du kommer att behöva en litet justeringsvidd.
- Till slut bör alla fästen spännas ordentligt med verktyg. I några skeden kommer du att behöva en stramare spänning för att profilerna skall hållas på sina platser vid monteringen.



Perustuksen teko on kasvihuoneen pystytyksen ensimmäinen vaihe. Suosittelemme seuraavia, vaihtoehtoisia ratkaisuja:

1. Valuperustus / oman metallisokkelin kiinnittäminen valuuun

Helpoin ja nopein tapa tehdä perustus kasvihuoneellesi on hyödyntää omaa mukana seuraavaa metallisokkeliä. sokkeli toimitetaan kokonaisuutena, joka sisältää kaikki tarvittavat osat huoneen kiinnitystä varten ja maa-ankkurit. Sokkeli on galvanoitua terästä ja juuri oikean mittainen huoneellesi. sokkelin korkeus on 15 cm, mikä kasvattaa kasvihuoneesi tilavuutta. Asennus: Valmis sokkeli kiinnitetään joko valamalla maa-ankkurit esimerkiksi tarkoitusta varten maahan upotettuihin muoviputkiin tai vastaaviin muotteihin. Tarkista maa-ankkureiden suoruus / tasakorkeus pitkää lautaa ja vesivaakaa käyttäen. Huomaa; lähetys ei sisällä muoviputkia tai muita valumuotteja eikä sementtiä. Metalliperustusta käytettäessä suositellaan lisäksi käytettäväksi tarkoitusta varten saatavaa suodatinkangasta, joka erottaa maa-ainekset toisistaan ja näin estää niiden sekoittumisen – täten saat varmistettua kasvumullan laadun ja pidettyä jo maaperässä mahdollisesti olevat rikkaruohot loitommalla .

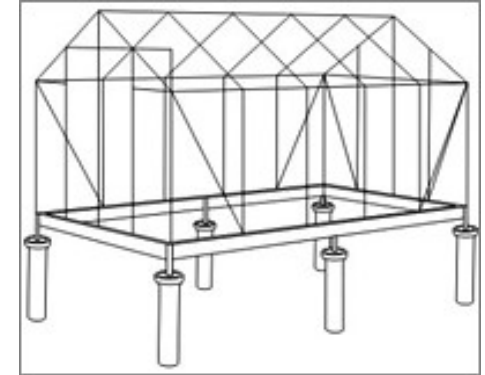

2. Harkkoperustus

Itse rakennettujen perustusten ulkomitat ovat samat kuin kyseisen kasvihuoneen valmisperustuksen mitat. Varaa perustukselle tasainen paikka , kaiva maata riittävältä syvyydeltä routimisen estämiseksi ja asenna pohjalle esim. styrox levyjä eristekerrokseksi . Laita eristyksen päälle min. 10cm sorapeti jonka yhteyteen voi myös lisäksi asentaa salaojaputket . Sorakerroksen päälle tulee hiekkaa , tiivistämään pohjaa . Perustuksen suoruus on syytä tarkistaa pitkällä lankulla ja vesivaakaa hyväksi käyttäen. Aseta harkot ja / tai painekyllästetyt koolingit tiivistetyn sorakerroksen päälle. Ankkuroi harkot / koolingit tukevasti kiinni maahan esim. riittävän suurilla rautatangoilla. Kiinnitä kasvihuoneen sokkeli tukevasti perustukseen .

Ohessa esimerkki harkkoperustuksen rakentamisesta, täydennetty painekyllästetyllä koolingilla.

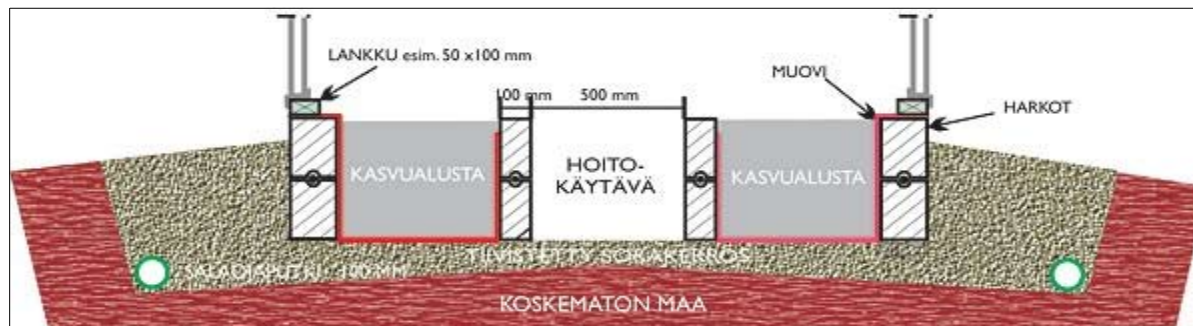

Yhteystiedot:

Horisont Enterprises Ltd Oy

Teerikukontie 6
FI - 00700 HELSINKI

puh: 09 - 6866 720

Fax: 09 - 6866 7222

office@horisontenterprises.fi
www.horisontenterprises.fi

PERUSTUKSET (Huom! Tarvikkeet EIVÄT SISÄLLY toimitukseen)

Kasvihuone voidaan tarvittaessa pystyttää valmiille perustukselle. Perustuksena voi olla esim. painekyllästetty koolinki tai lekaharkko.

Varaa perustukselle tasainen paikka. Kaiva maata riittävältä syvyydeltä routimisen estämiseksi ja asenna pohjalle styrox eristekerros. Laita eristeiden päälle n.10 cm sorakerros ja sen päälle n.5 cm hienoa hiekkaa. Tarkista perustuksen suoruu pitkää lautaa ja vesivaakaa käyttäen. Aseta koolingit/lekaharkot tasatun hiekkakerroksen päälle. Varmista perustuksen suoruu ristimitalla sen sisäkulmista. Kiinnitä koolingit toisiinsa kulmaraudoilla. Ankkuroi koolingit/lekaharkot tukevasti kiinni maahan esim. riittävän suurilla rautatangoilla. Kiinnitä kasvihuoneen sokkeli tukevasti perustukseen.

Yhteystiedot:**Maahantuojaja:****Horisont Enterprises Ltd Oy**

Teerikukontie 6, 00700 Helsinki

Puh. 09 - 6866720

office@horisontenterprises.fi

www.horisontenterprises.fi

Varaosat:

sähköposti: varasto@horisontenterprises.fi

fax: 09 - 6866 7222

Huom!

Ilmoita tarkasti tarvitsemasi varaosan numero.

(kts. ohjeen osaluettelo)

Neuvonta:

puh. 040 - 822 32 82 / 09 - 68 66 720

Tiedustele myyjäliikkeestä kasvihuoneen maksullista pystytyspalvelua.

Contents

Item	Inc./cm	Qty.
962	86 ¹ / ₄ / 219	2

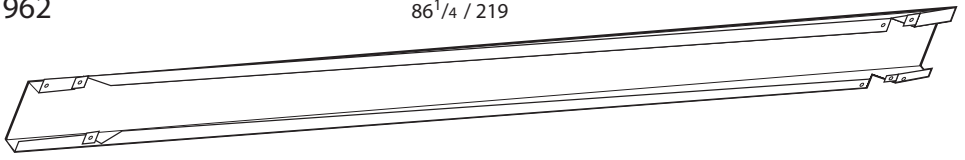

963	114 ¹ / ₄ / 290	2
-----	---------------------------------------	---

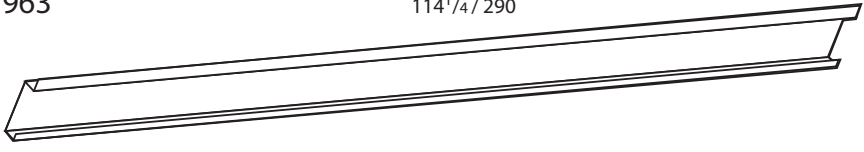

974	117 ³ / ₄ / 299	2
-----	---------------------------------------	---

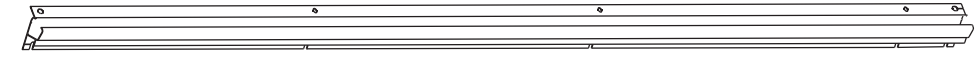

975	117 ³ / ₄ / 299	1
-----	---------------------------------------	---



287	70 / 178	1
-----	----------	---

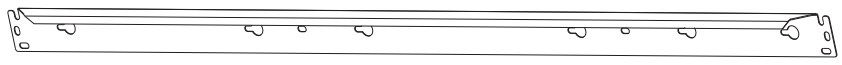

Item	Inc./cm	Qty.
994	67 / 170	1

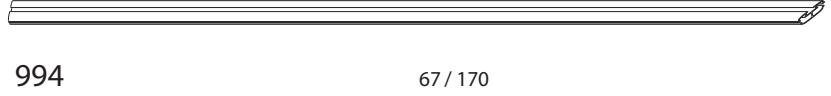

995	67 / 170	1
-----	----------	---

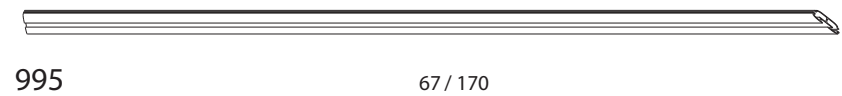

987	65 / 165	1
-----	----------	---

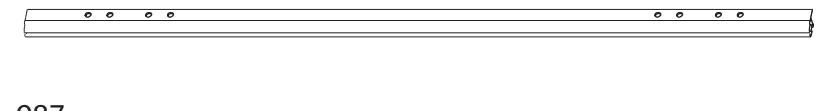

988	65 / 165	1
-----	----------	---



985	64 / 163	2
-----	----------	---

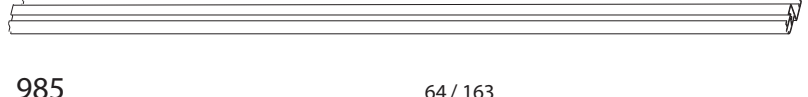

Contents

Item	Inc./cm	Qty.
256	50 ³ / ₄ / 129	8

993	46 / 117	16
-----	----------	----

996	46 / 117	8
-----	----------	---

3017	22 ³ / ₄ / 53	2
3016	64 / 163	1

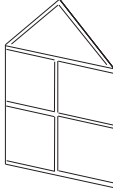
Item	Qty.
553 	1

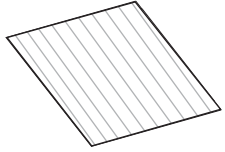
586 	2
--	---

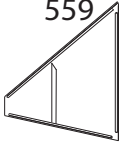
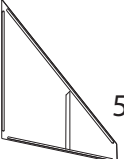
559 	2
560 	2

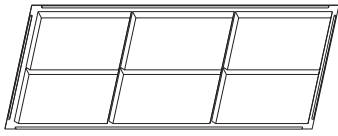
550 	15
---	----

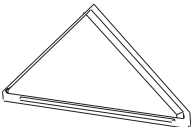
570 	1
--	---

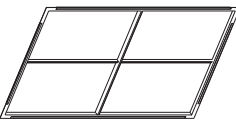
567 	2
--	---

Item	Inc./cm	Qty.
989	24 ¹ / ₄ / 61.5	1

991	24 ¹ / ₄ / 61.5	1
-----	---------------------------------------	---

992	22 ³ / ₄ / 58	2
-----	-------------------------------------	---

984	21 ¹ / ₂ / 55	2
-----	-------------------------------------	---

981	22 / 56	10
-----	---------	----

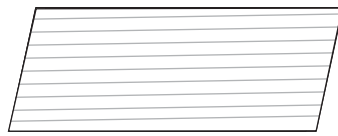
581 	9
---	---

Item	Inc./cm	Qty.
286	24 / 61	2











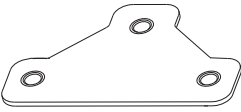

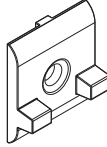

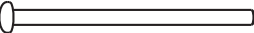
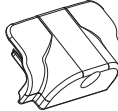
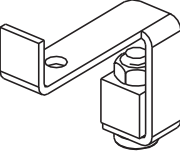

999	22 / 56	5
-----	---------	---

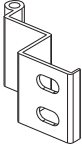
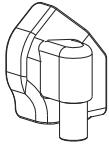
986	24 ³ / ₄ / 63	1
-----	-------------------------------------	---

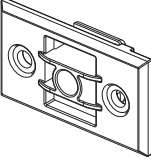
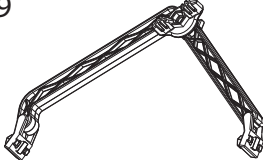
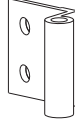
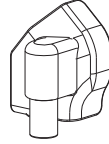
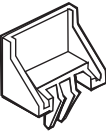
983	18 ¹ / ₂ / 47	1
-----	-------------------------------------	---

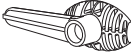
990	22 / 56	1
-----	---------	---

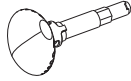
Contents

Item	Qty.	Item	Qty.	Item	Qty.	Item	Qty.	Item	Qty.
	3		112 spare 4		1		2		20 spare 1
	9 spare 1		112 spare 4		2		8		1
	9 spare 1		1		2		2		9 spare 1
	1		1		4		2		
	31 spare 1		2		9 spare 1		1		
	4		(1 spare) 3		1		9 spare 1		

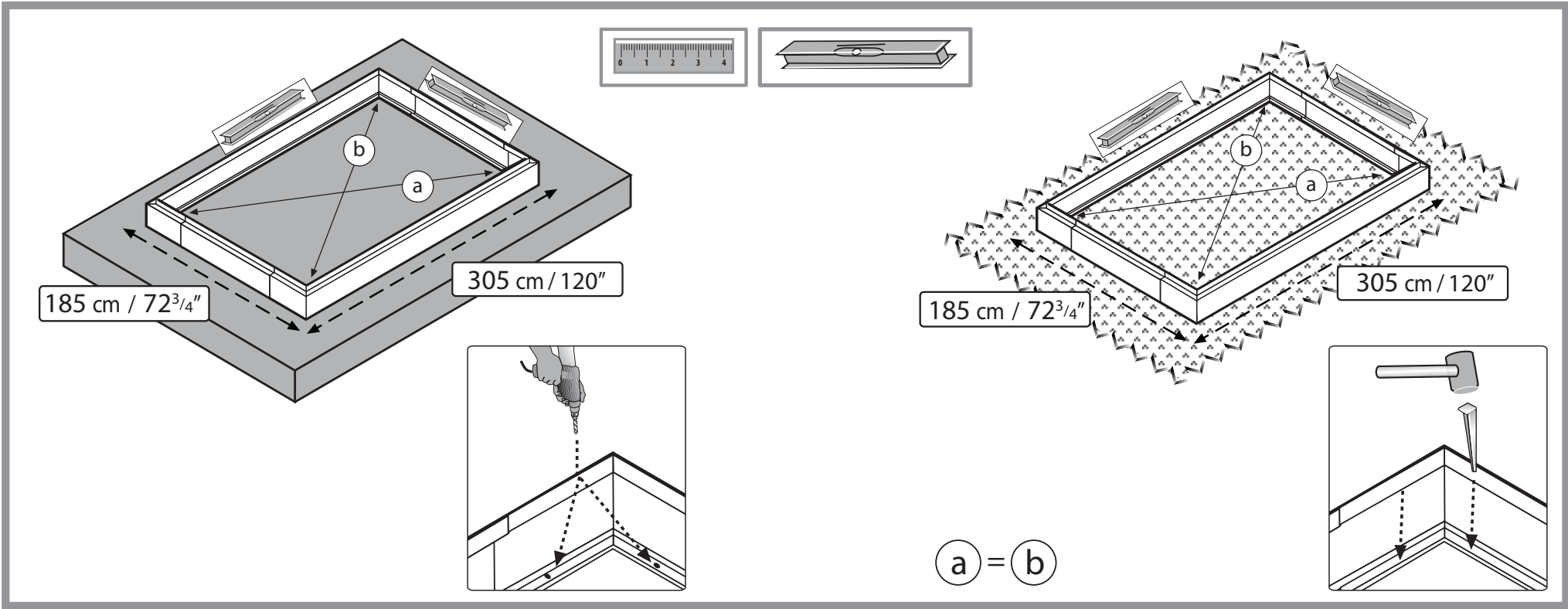
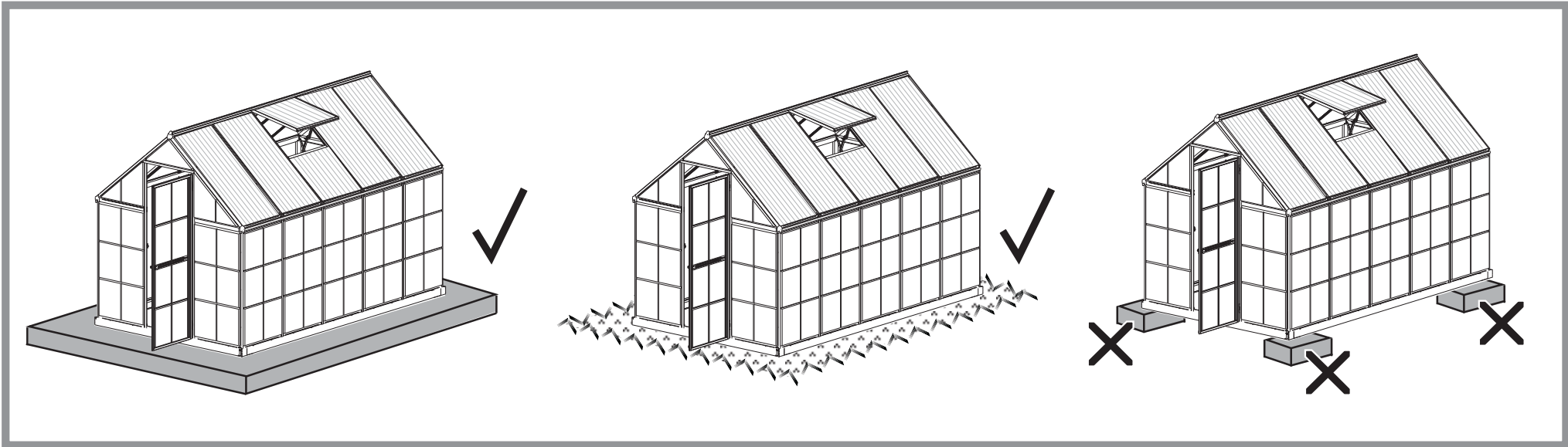

1

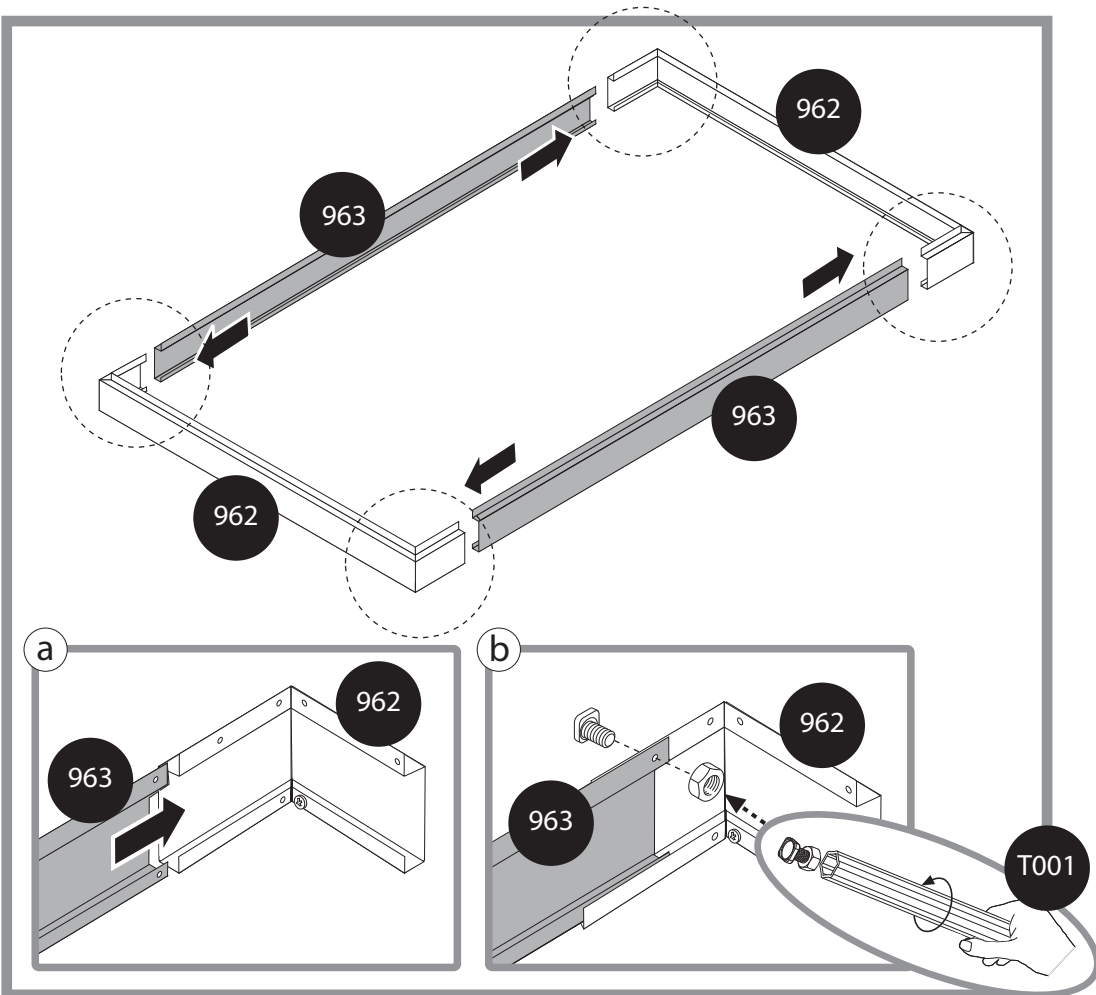
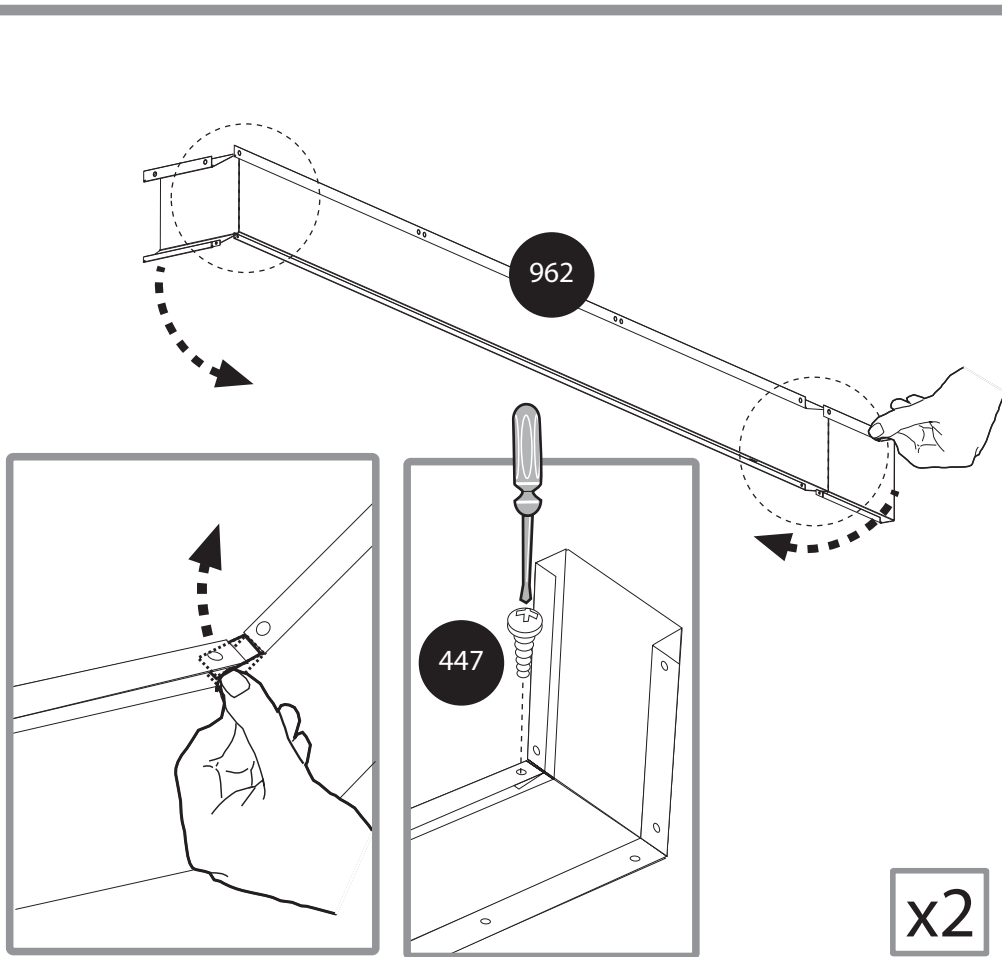
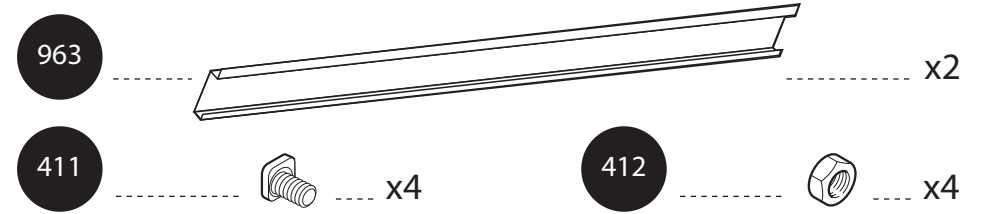
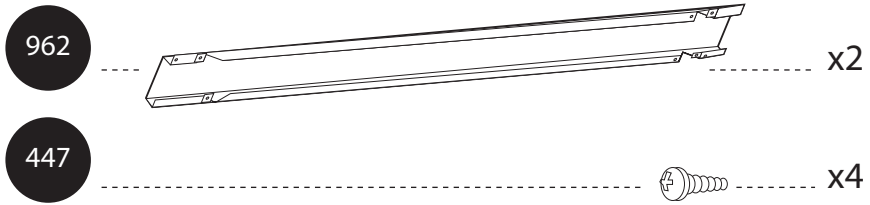
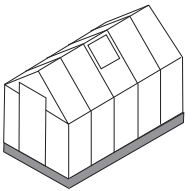

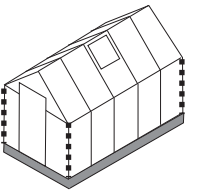

996

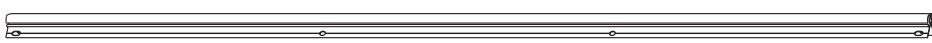

x4

412



x8

411



x8

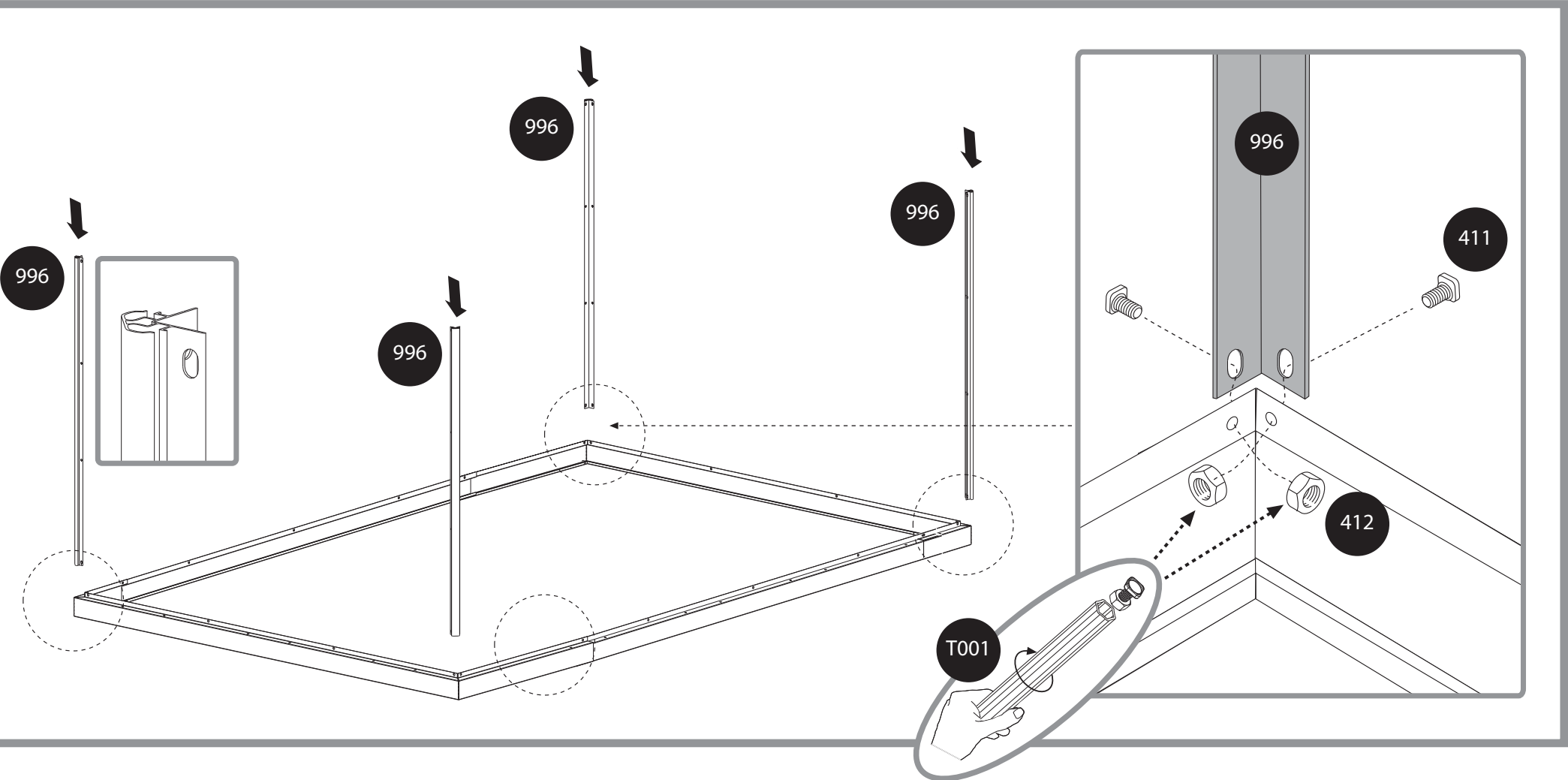

3

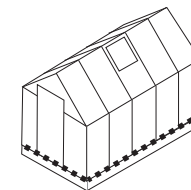

412  x12

411  x12

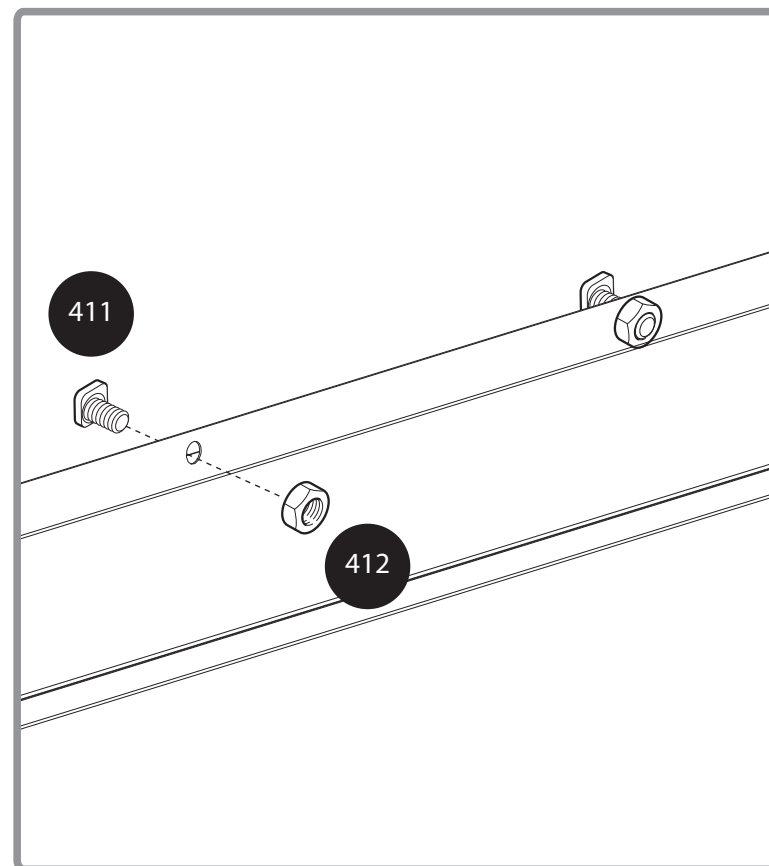
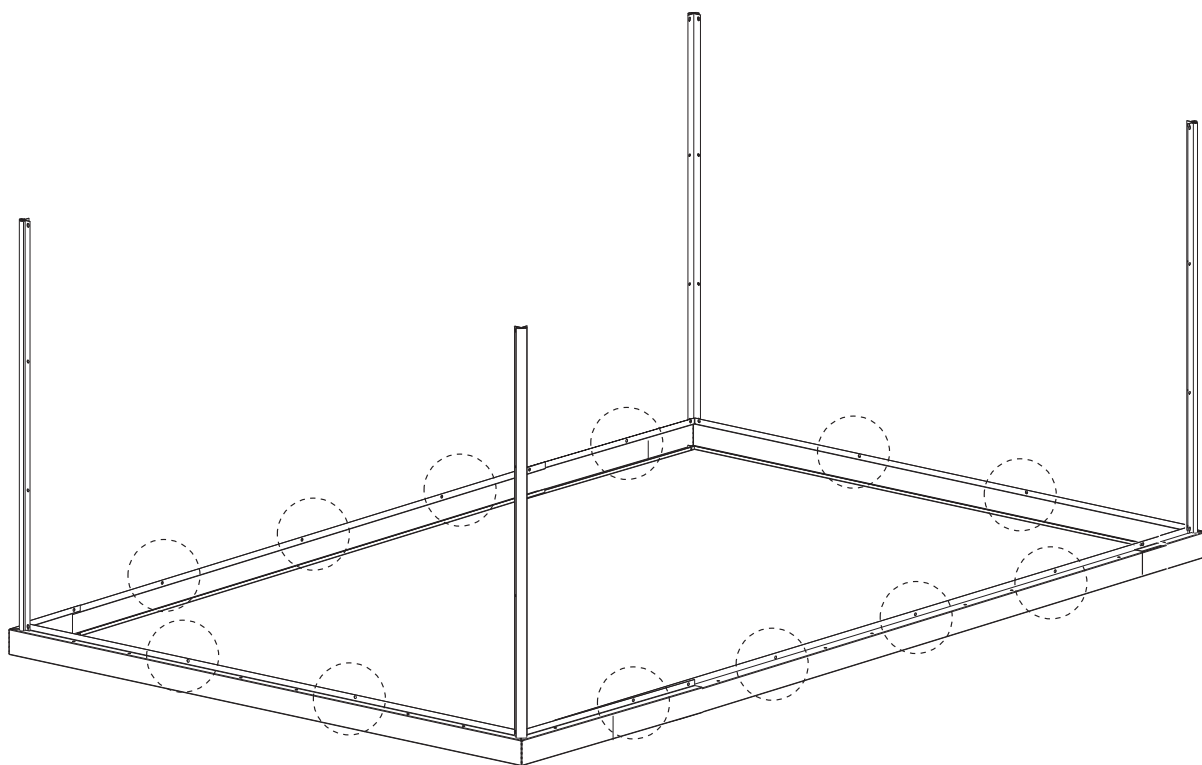

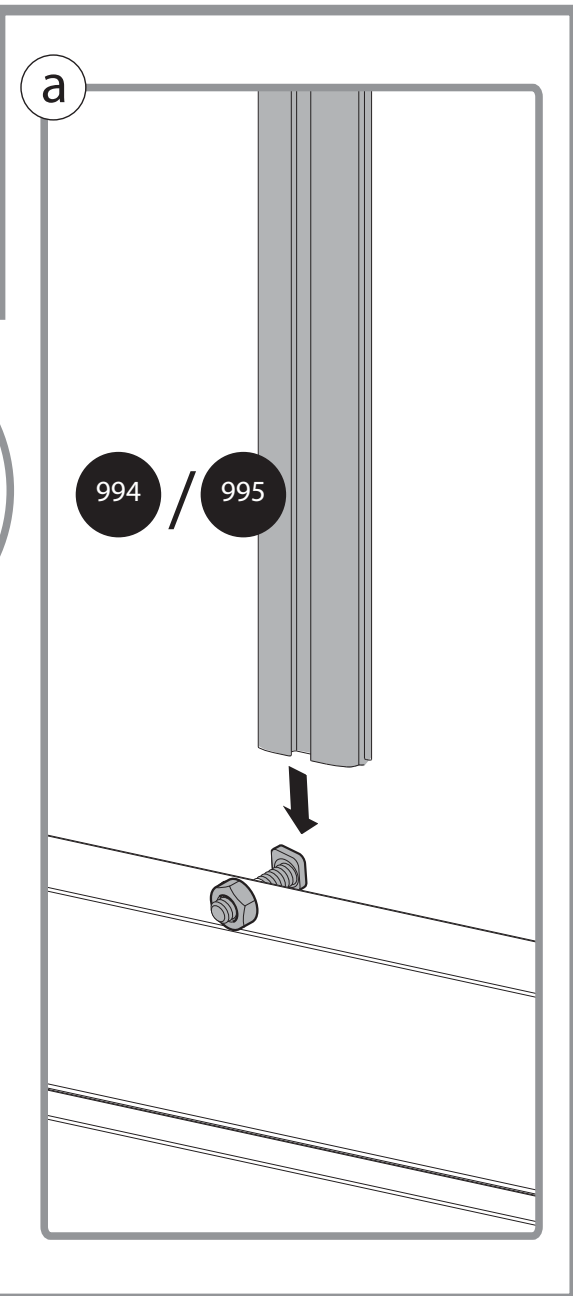
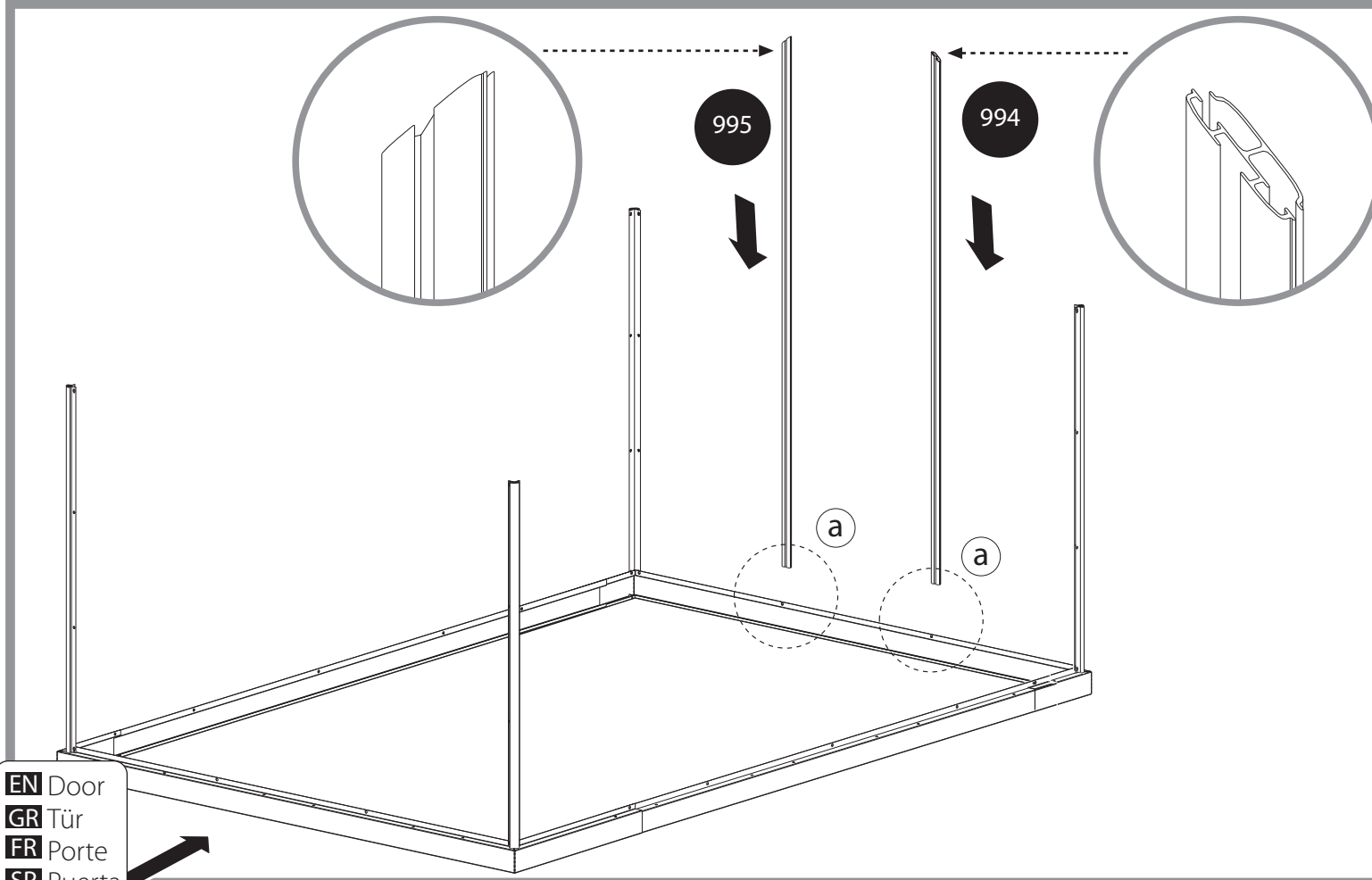
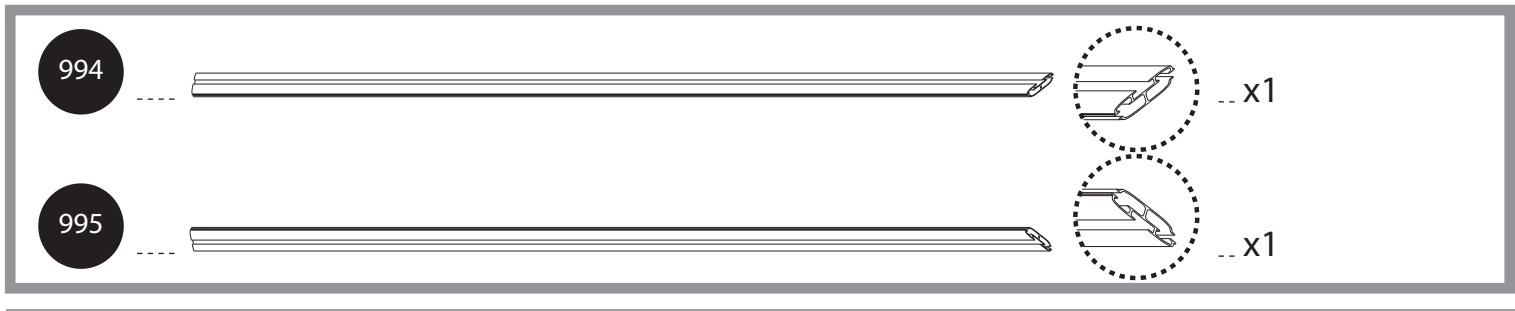
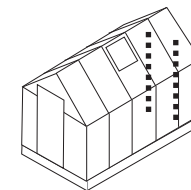

EN Door
 GR Tür
 FR Porte
 SP Puerta

5

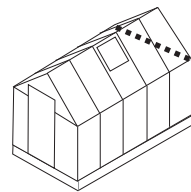

287x1

412 x2

411 x2

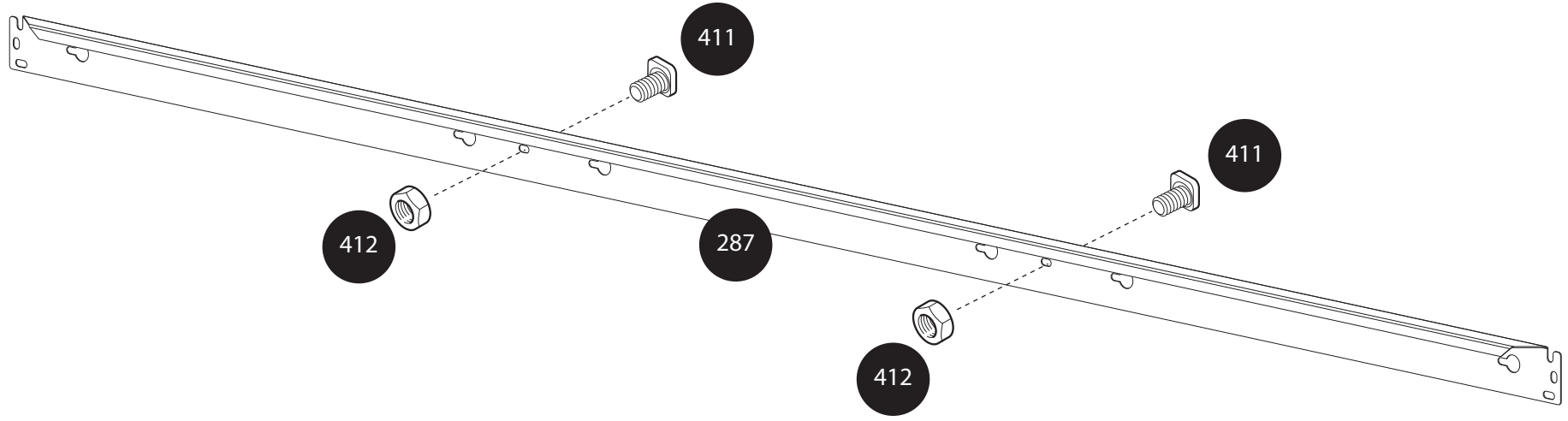

6

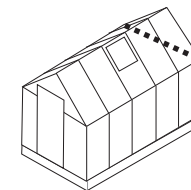

287

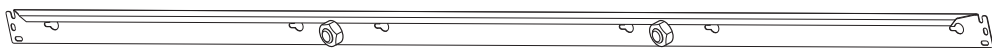

x1

411



x2

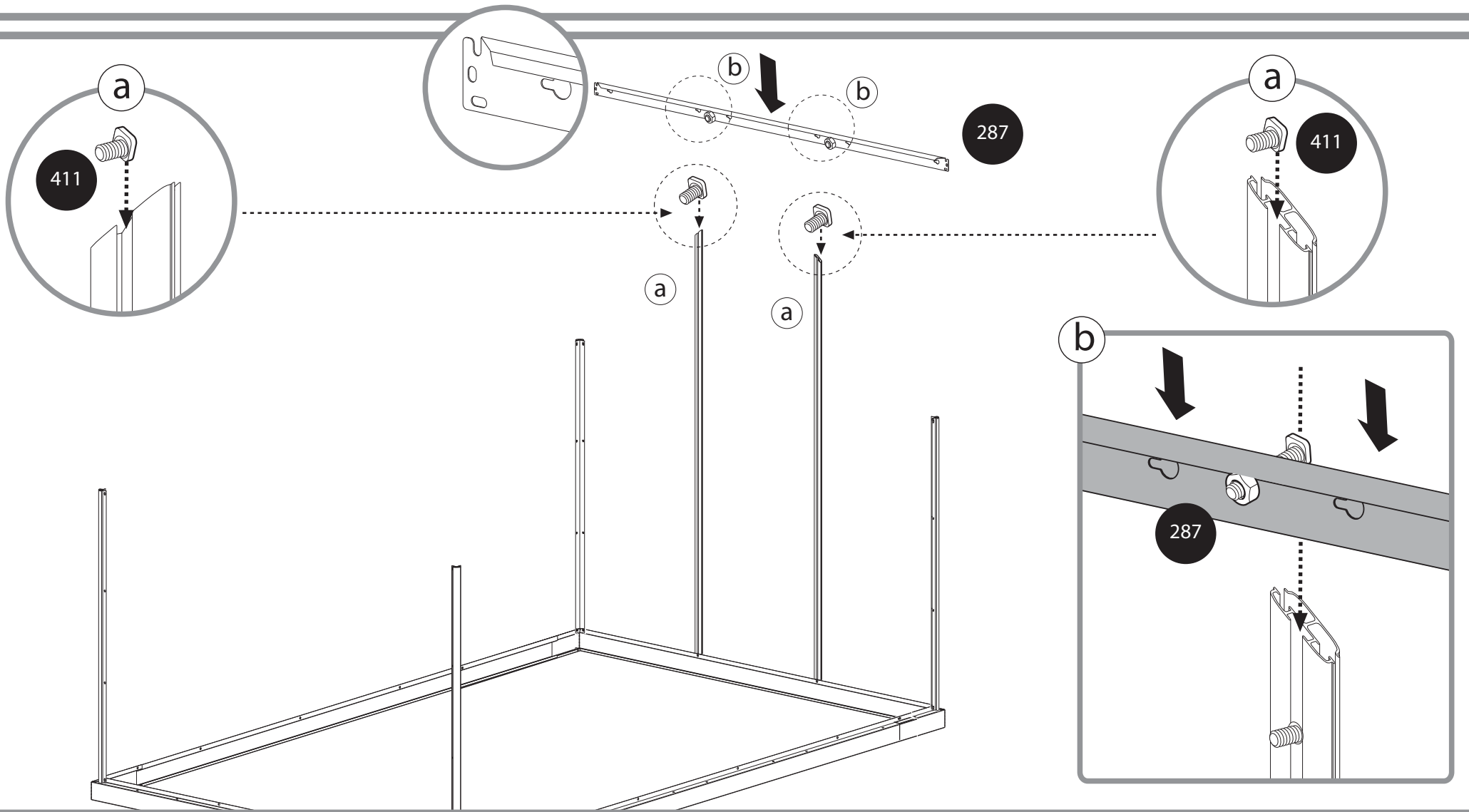

7

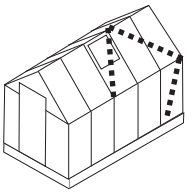

256

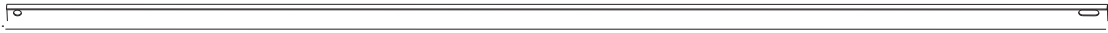

x2

412



x4

411



x2

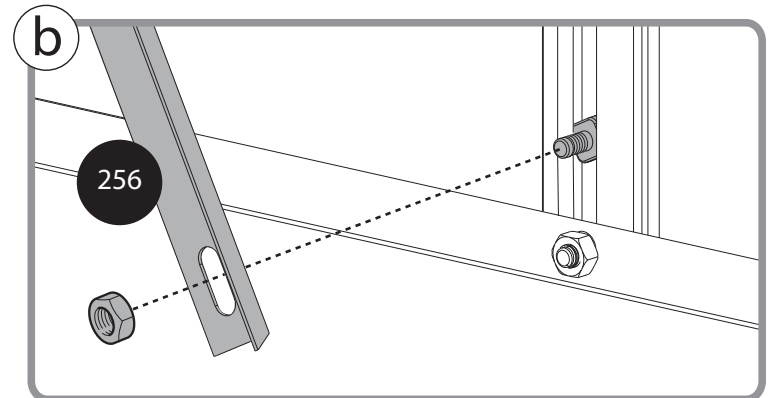
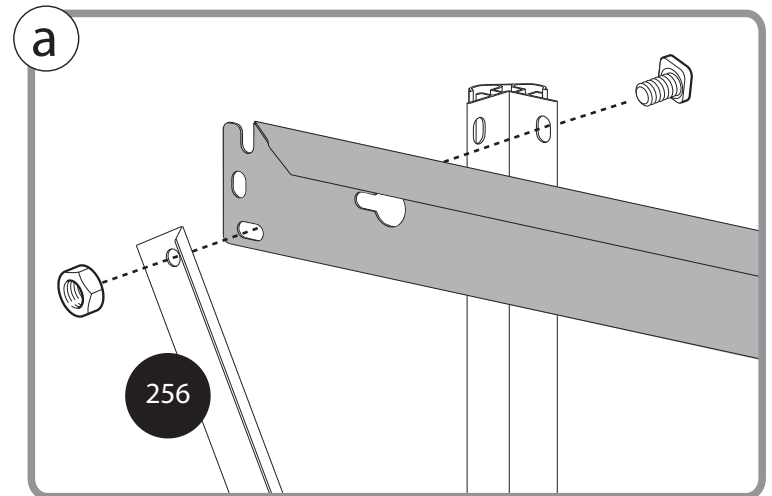
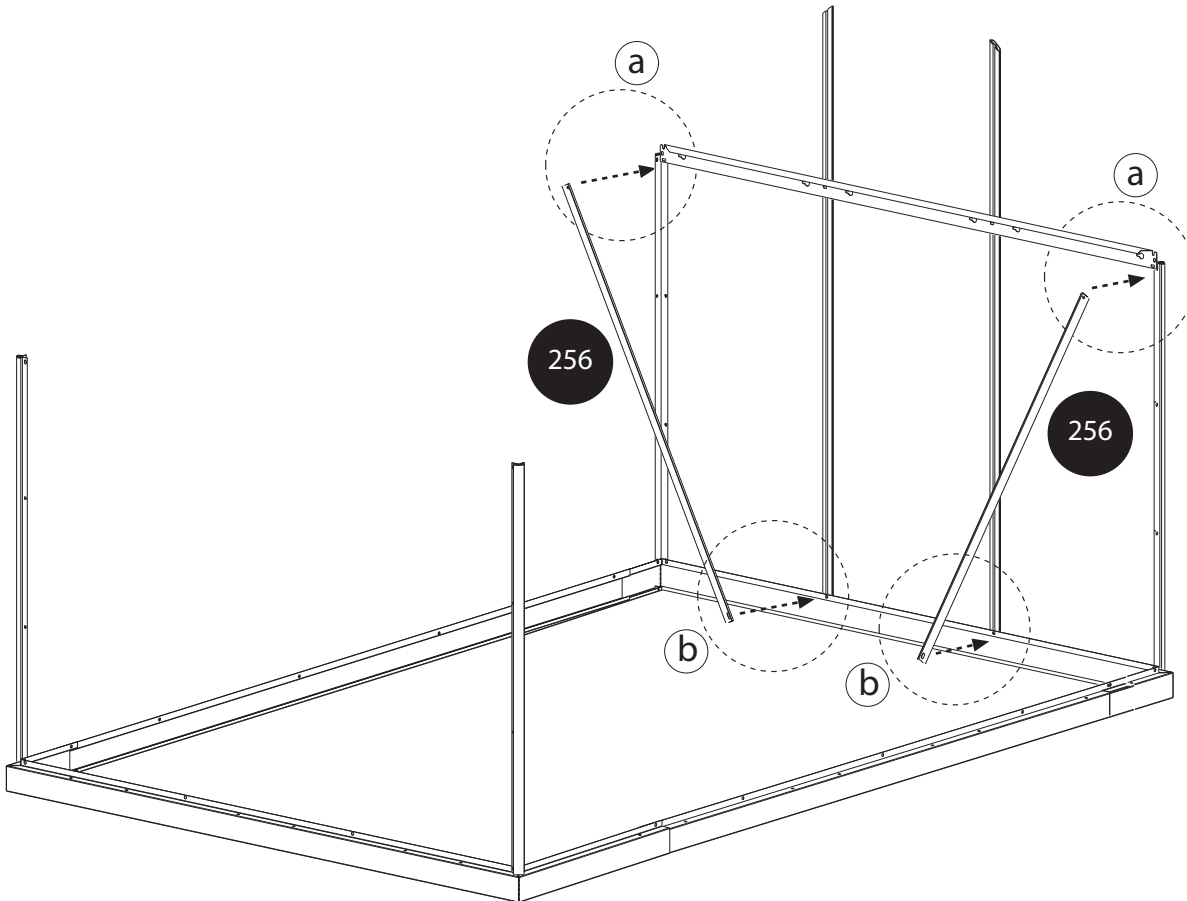

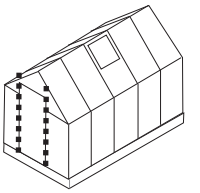

988

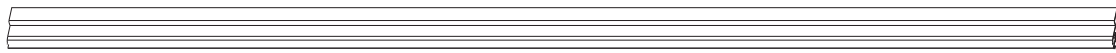

x1

987

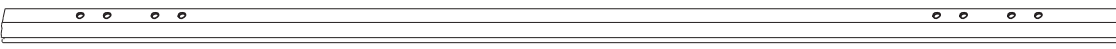

x1

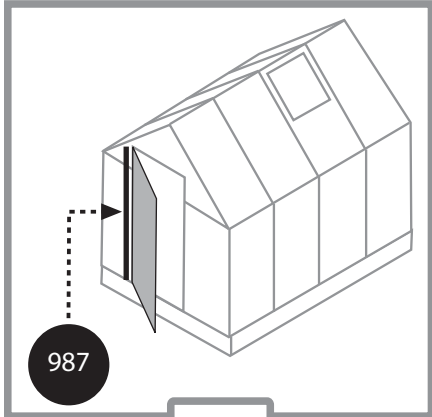

987

or

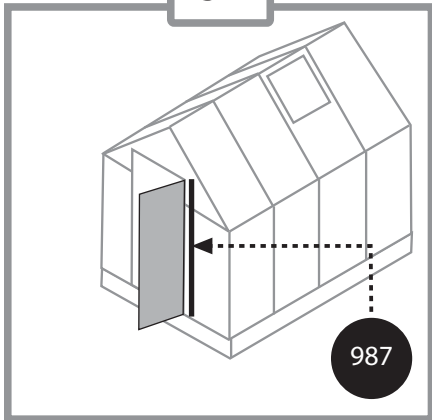

987

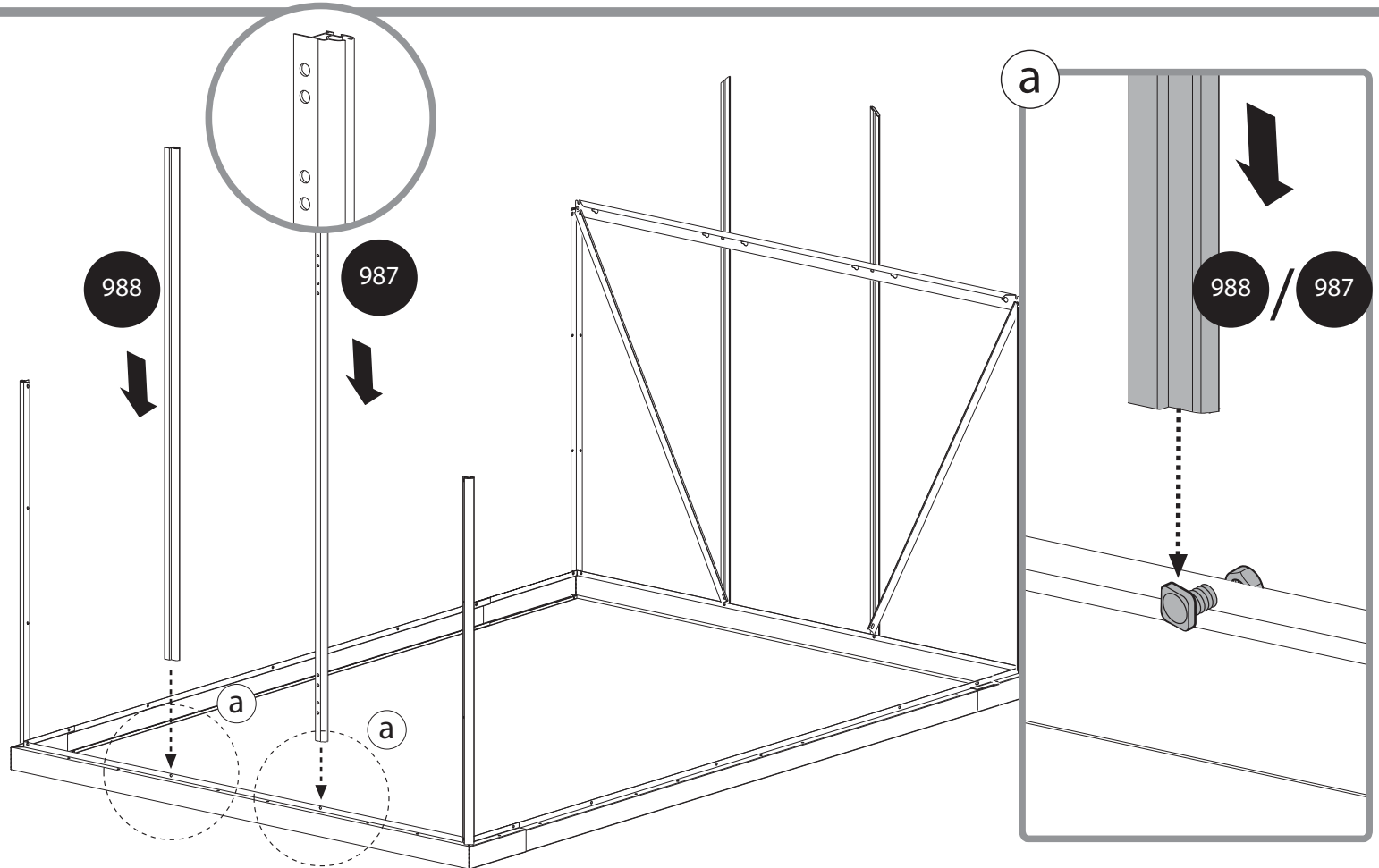

988

987

a

988

987

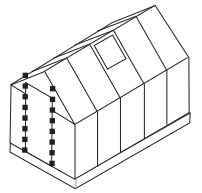

345

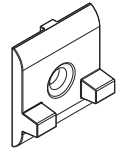

x1

411



x3

412



x1

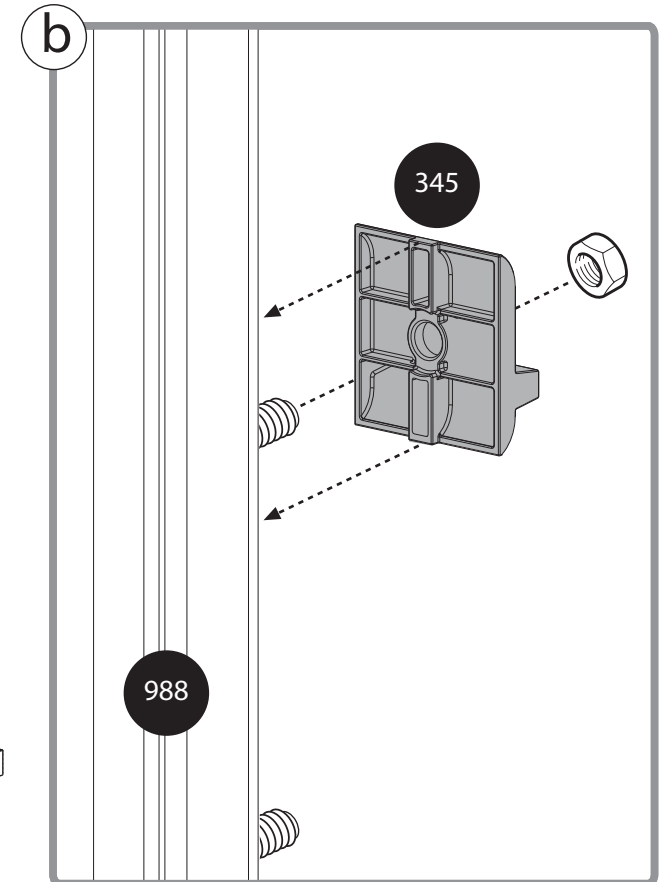
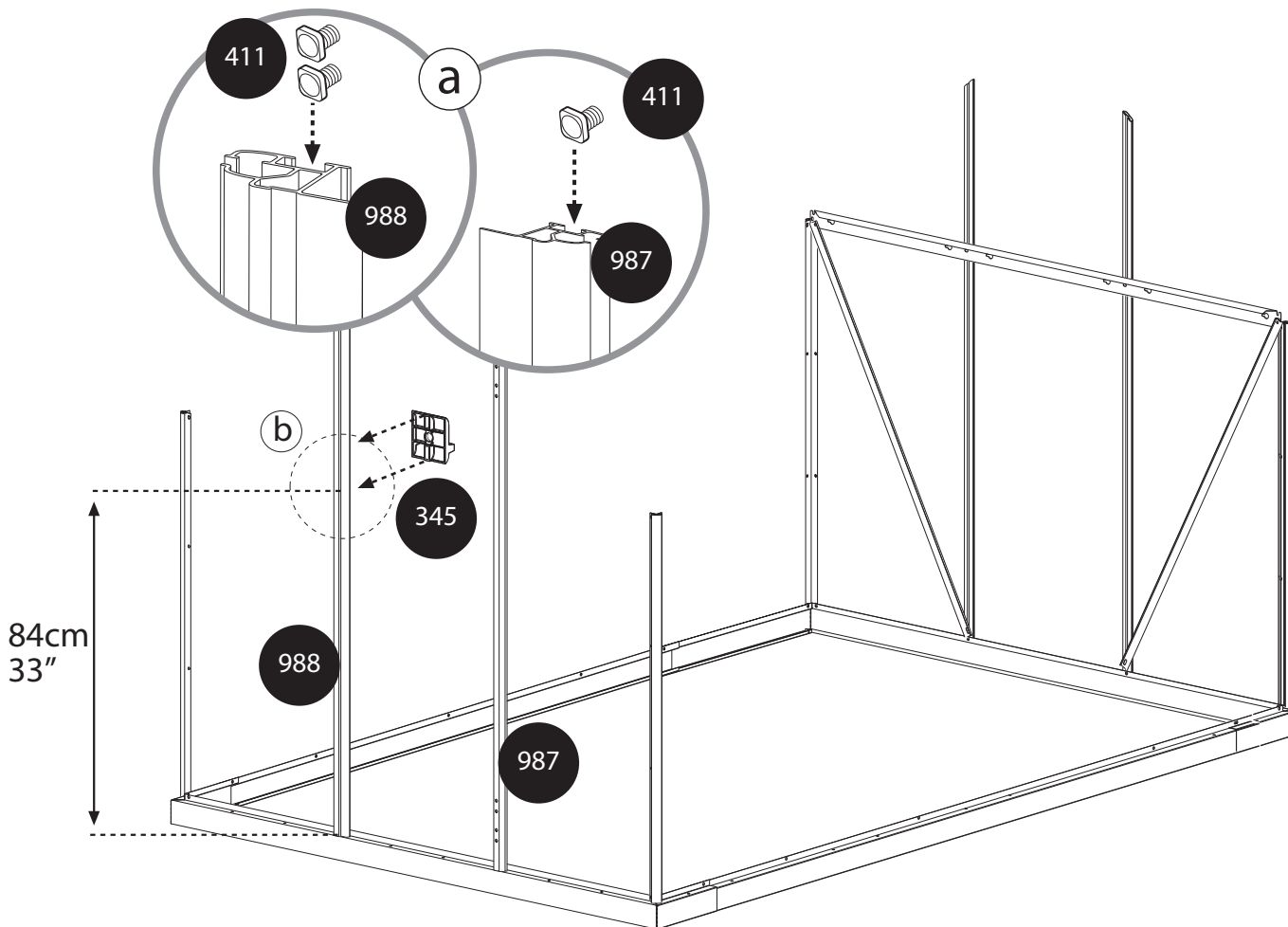

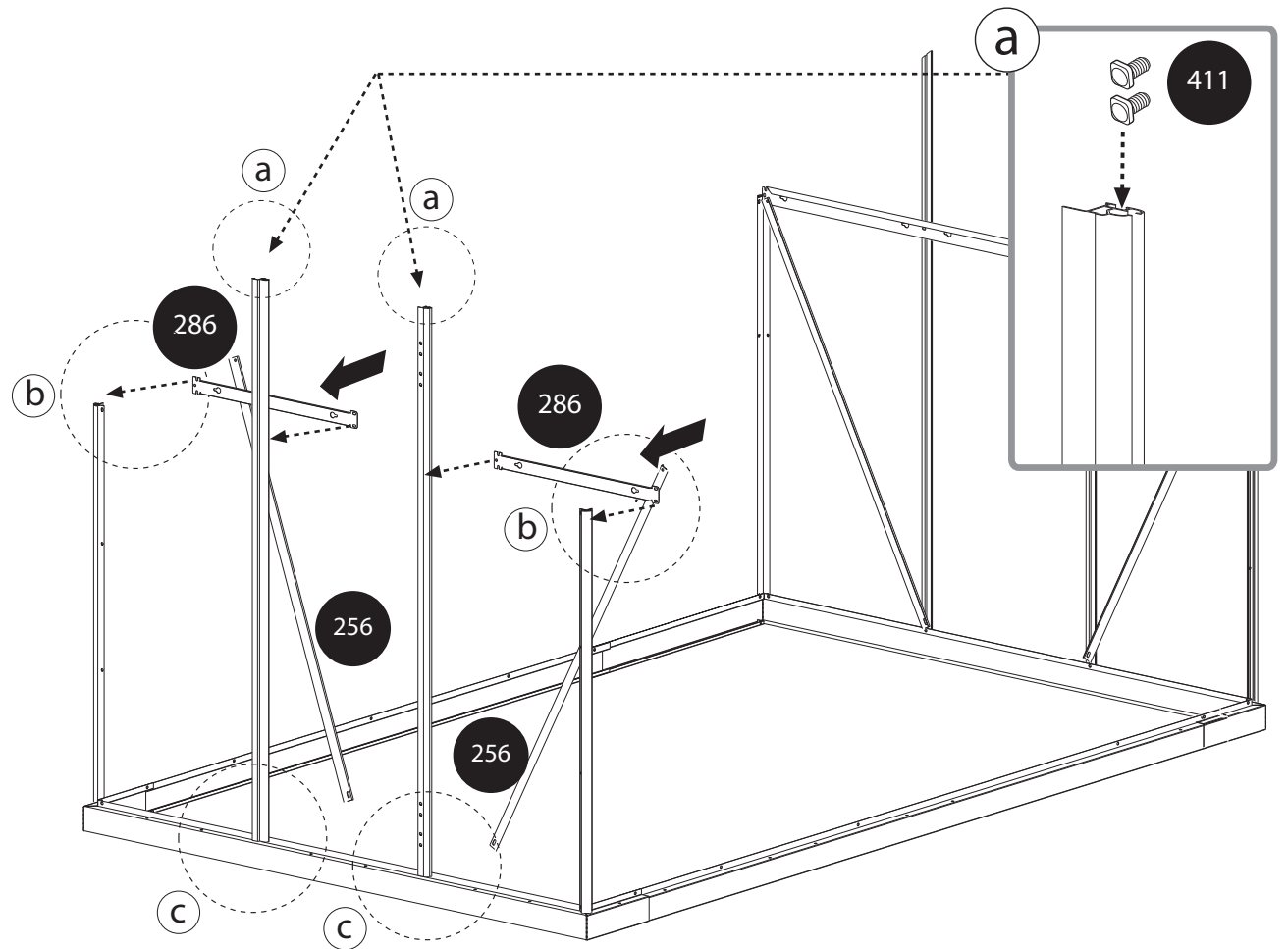
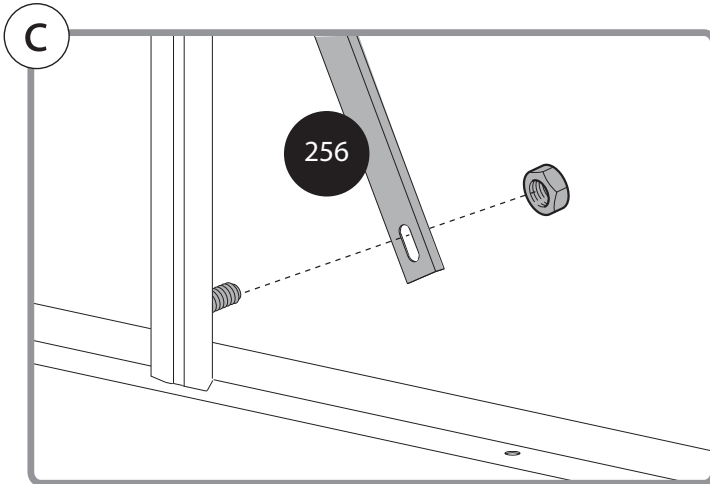
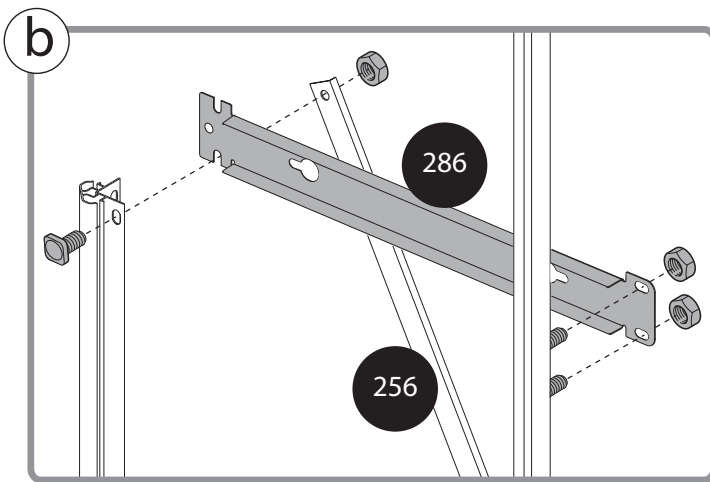
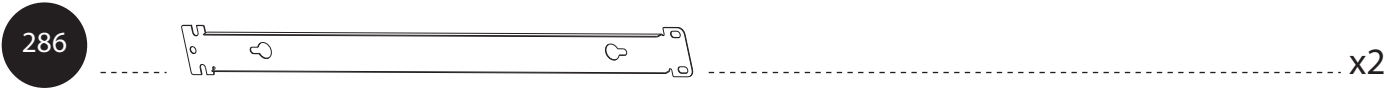
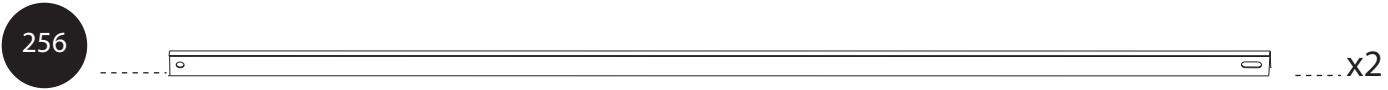
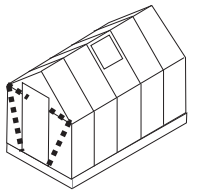

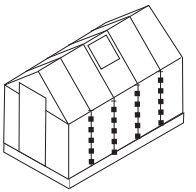

993

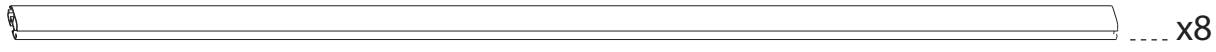
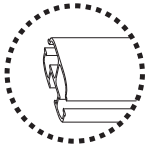

993

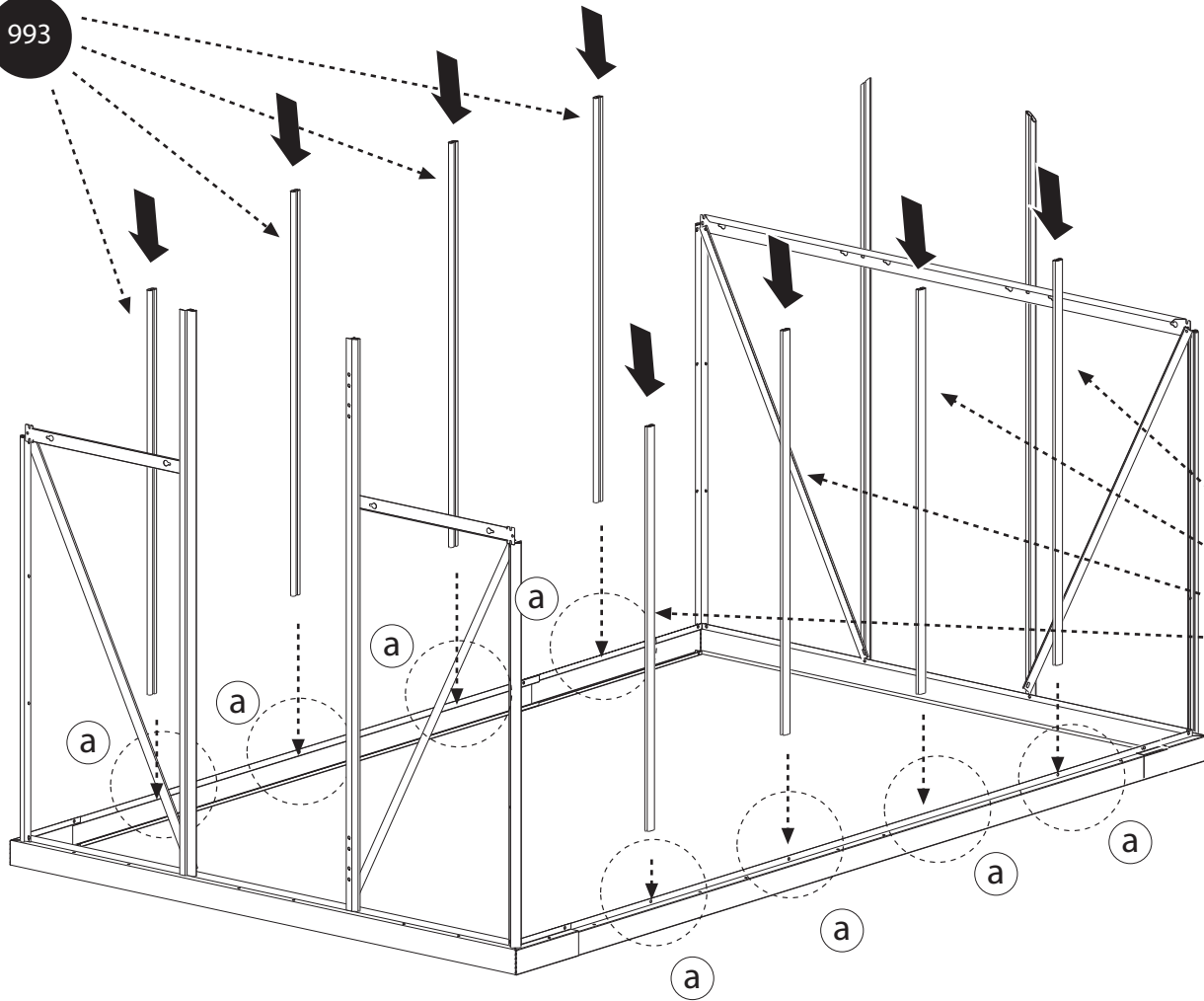

a

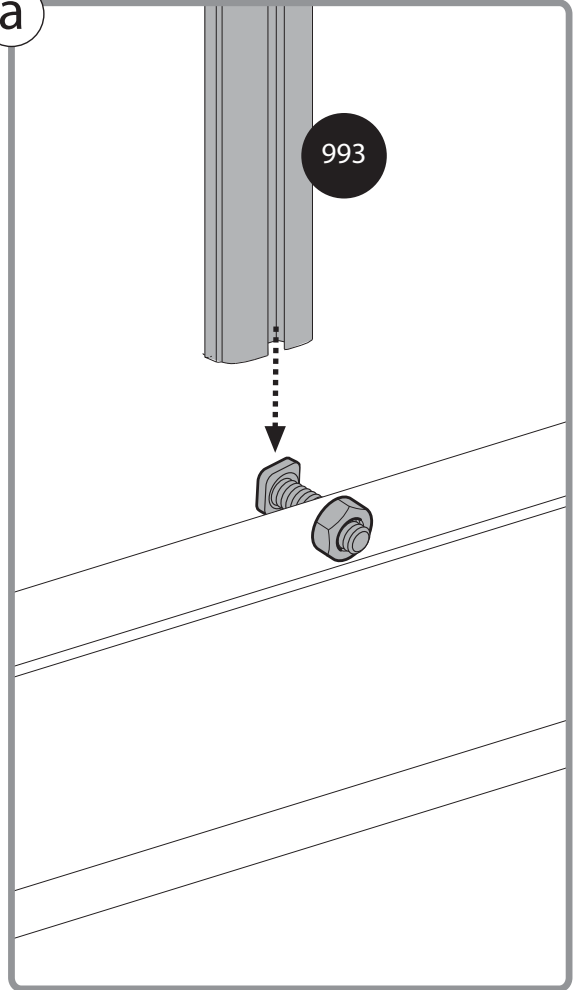

993

993

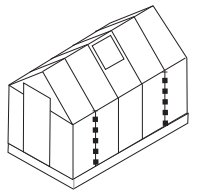

411

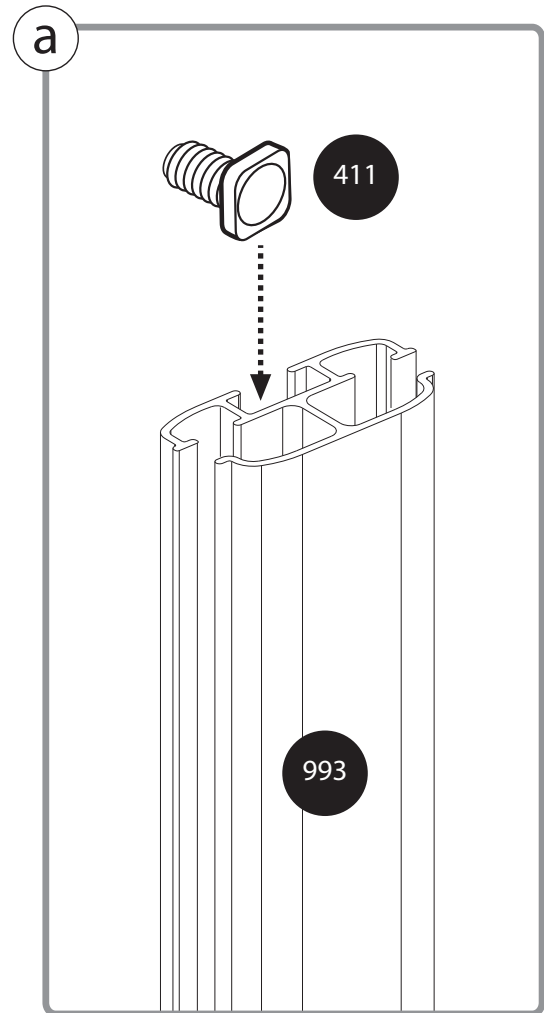
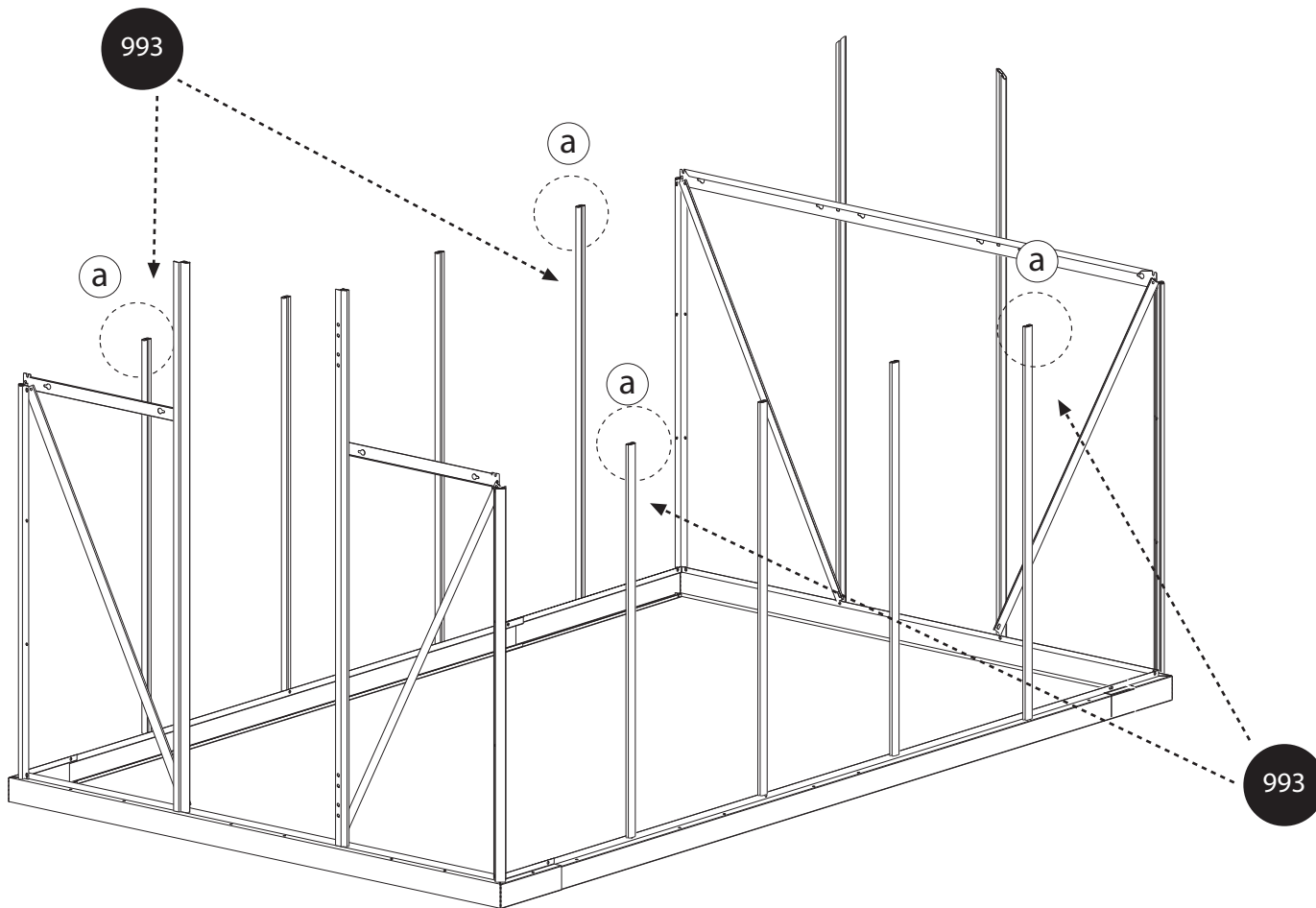

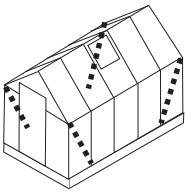

411  x4

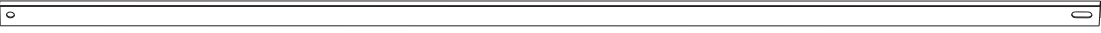
256  x4

412  x8

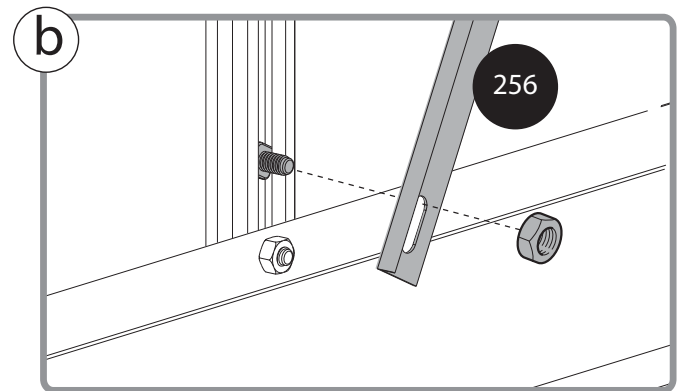
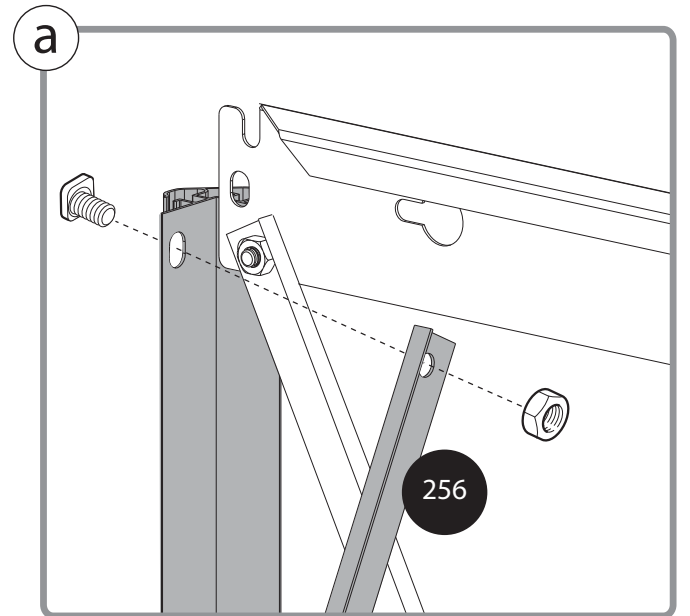
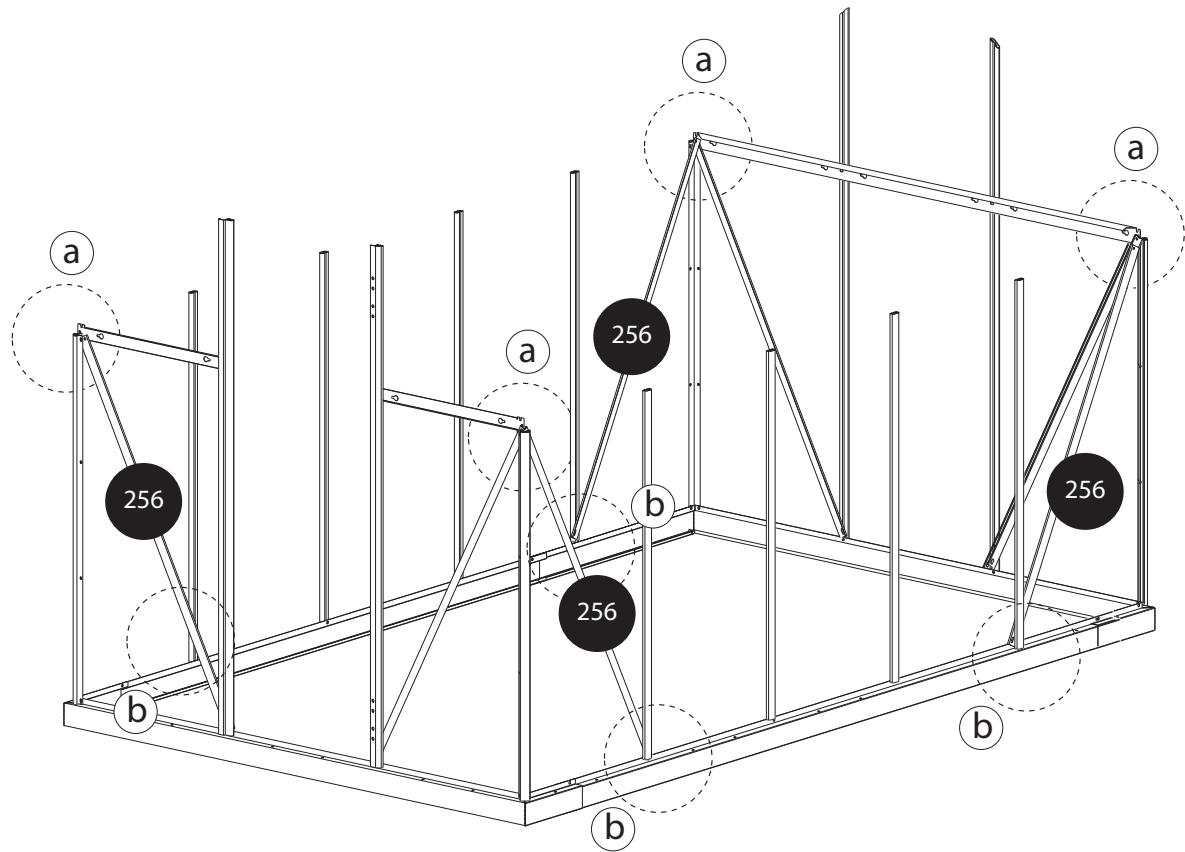

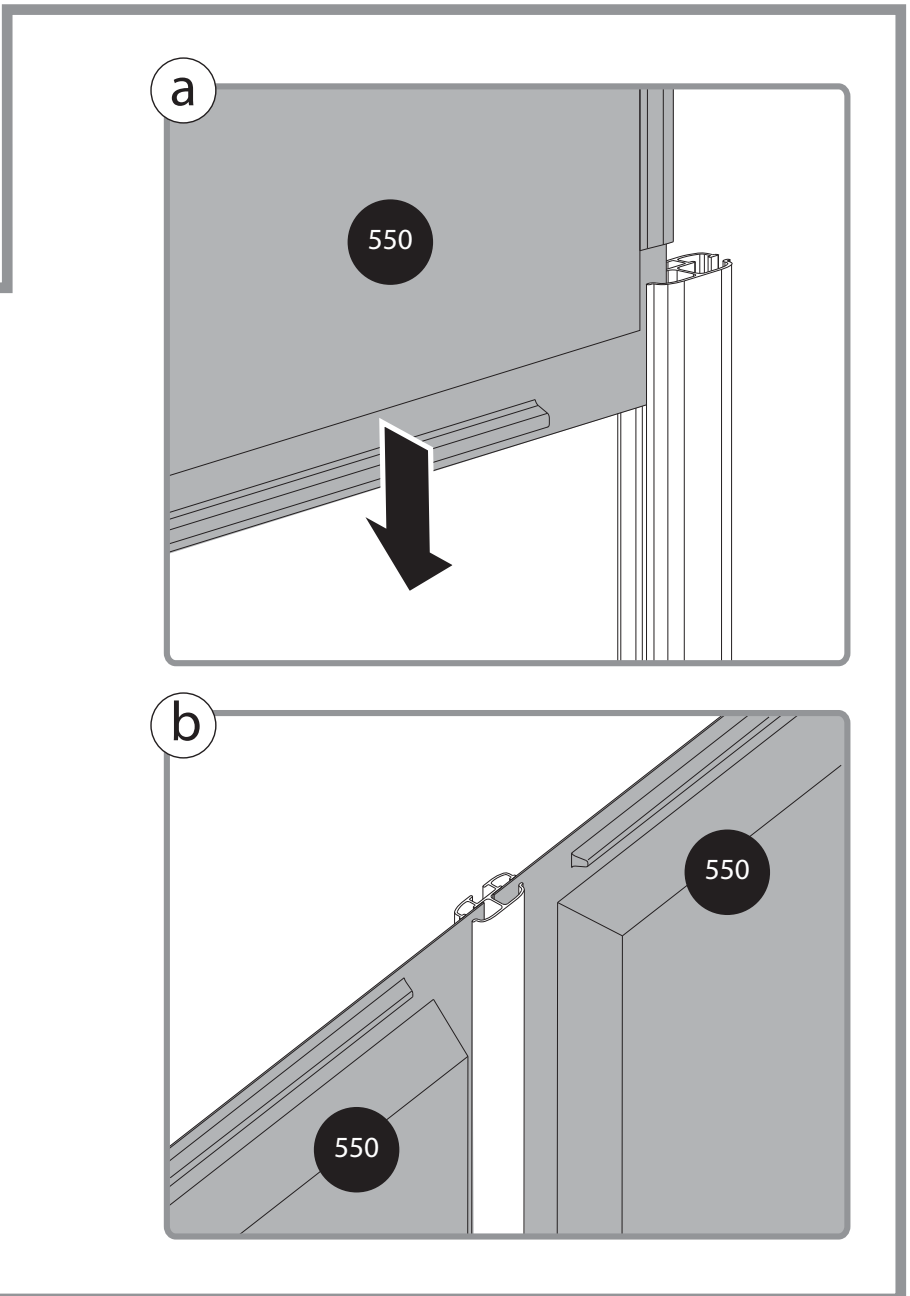
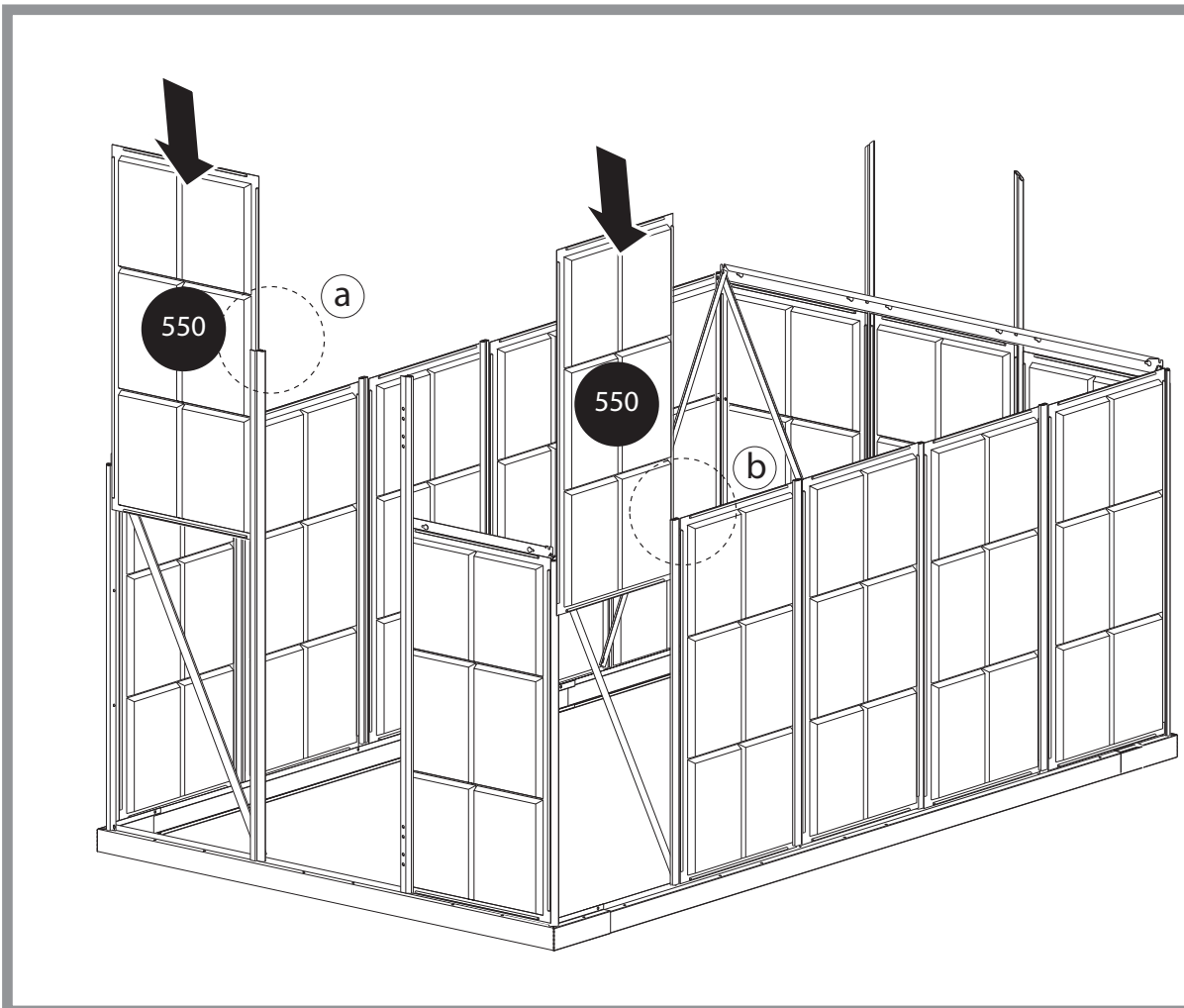
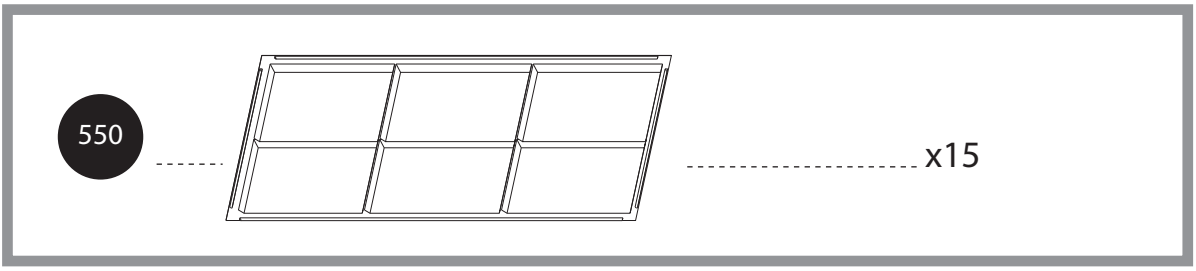
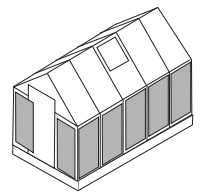

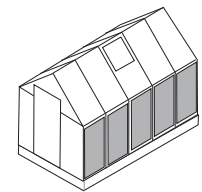

318
PVC

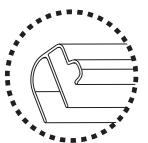

x10

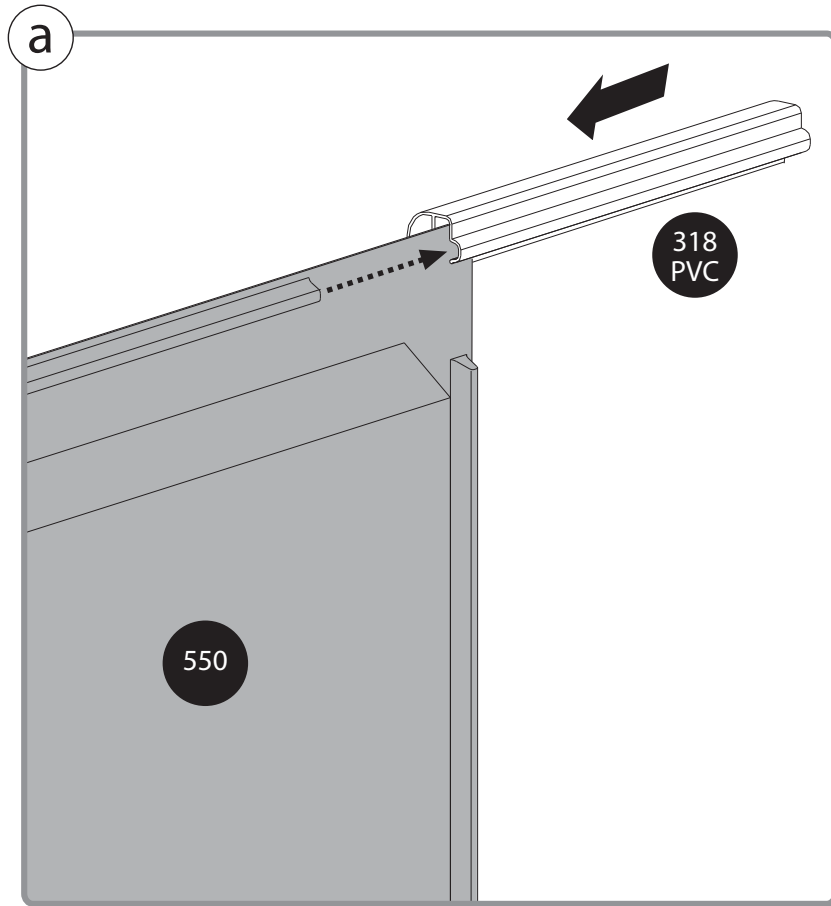
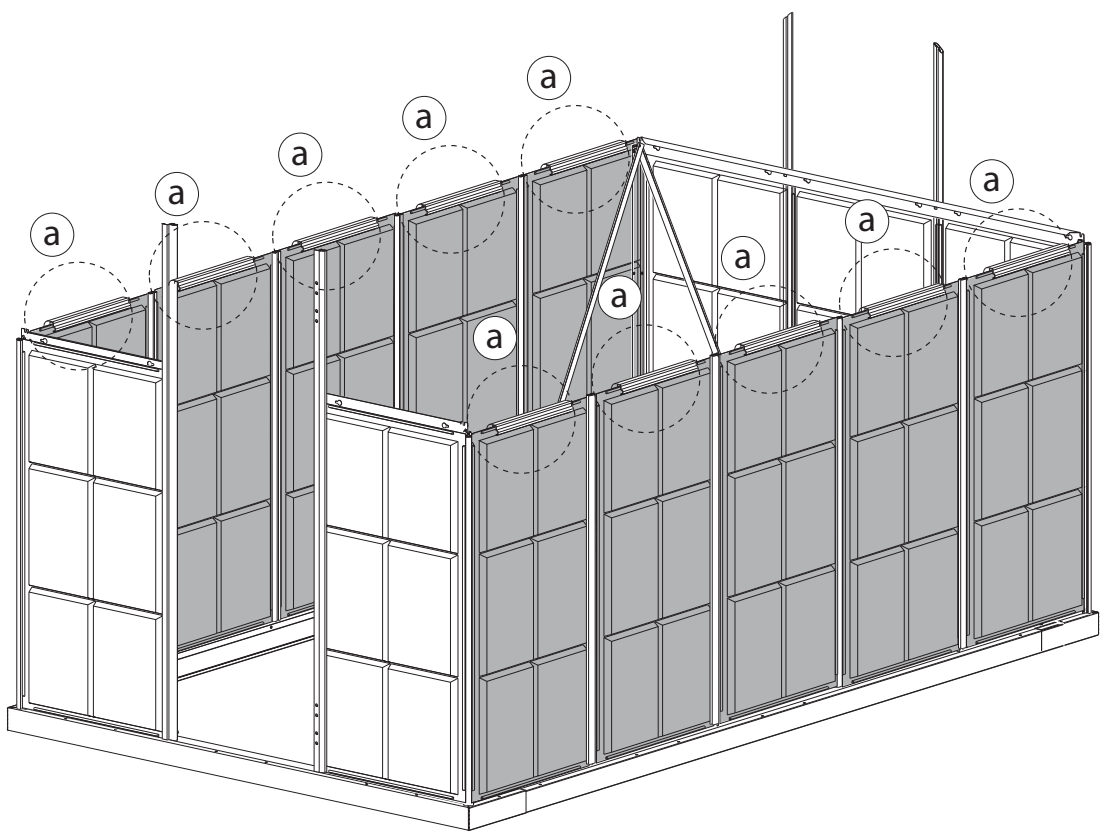

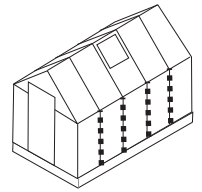

412



411

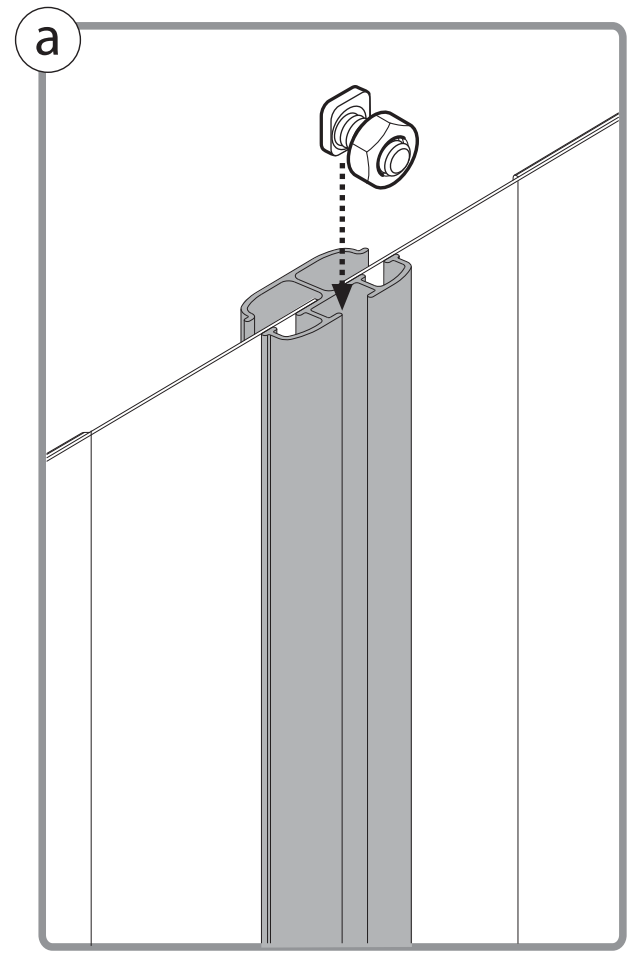
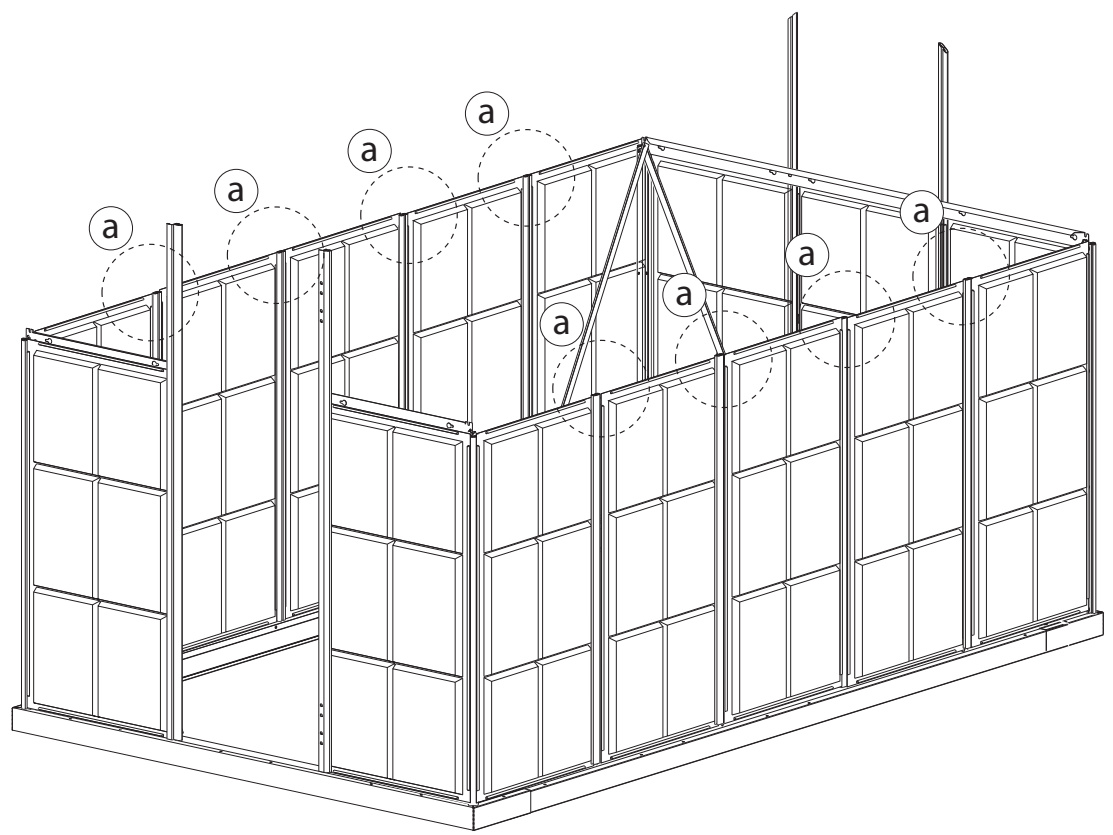
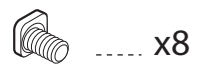

17

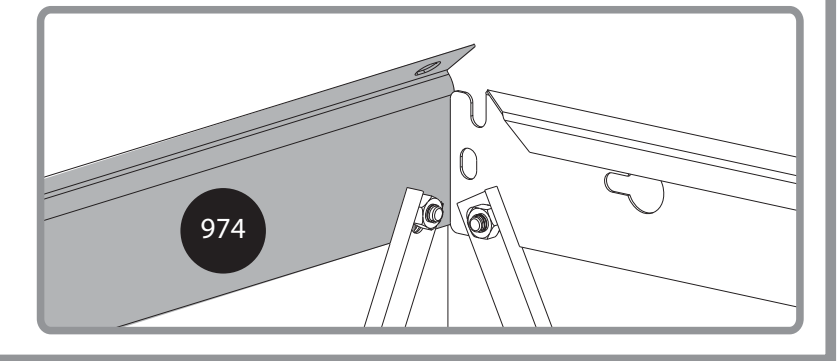
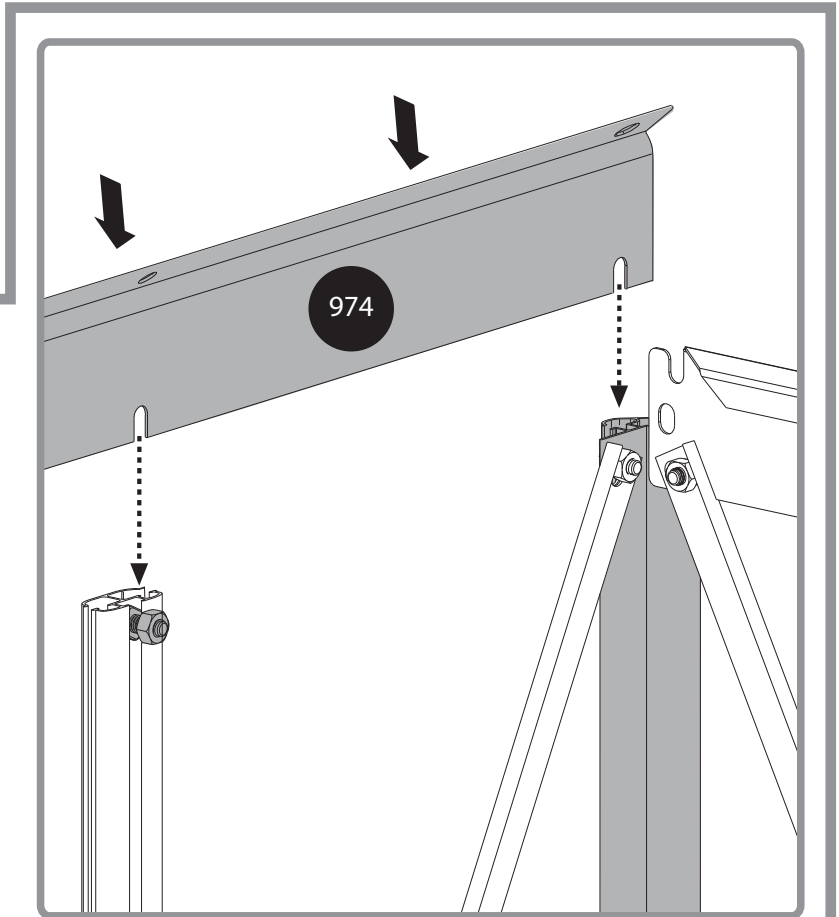
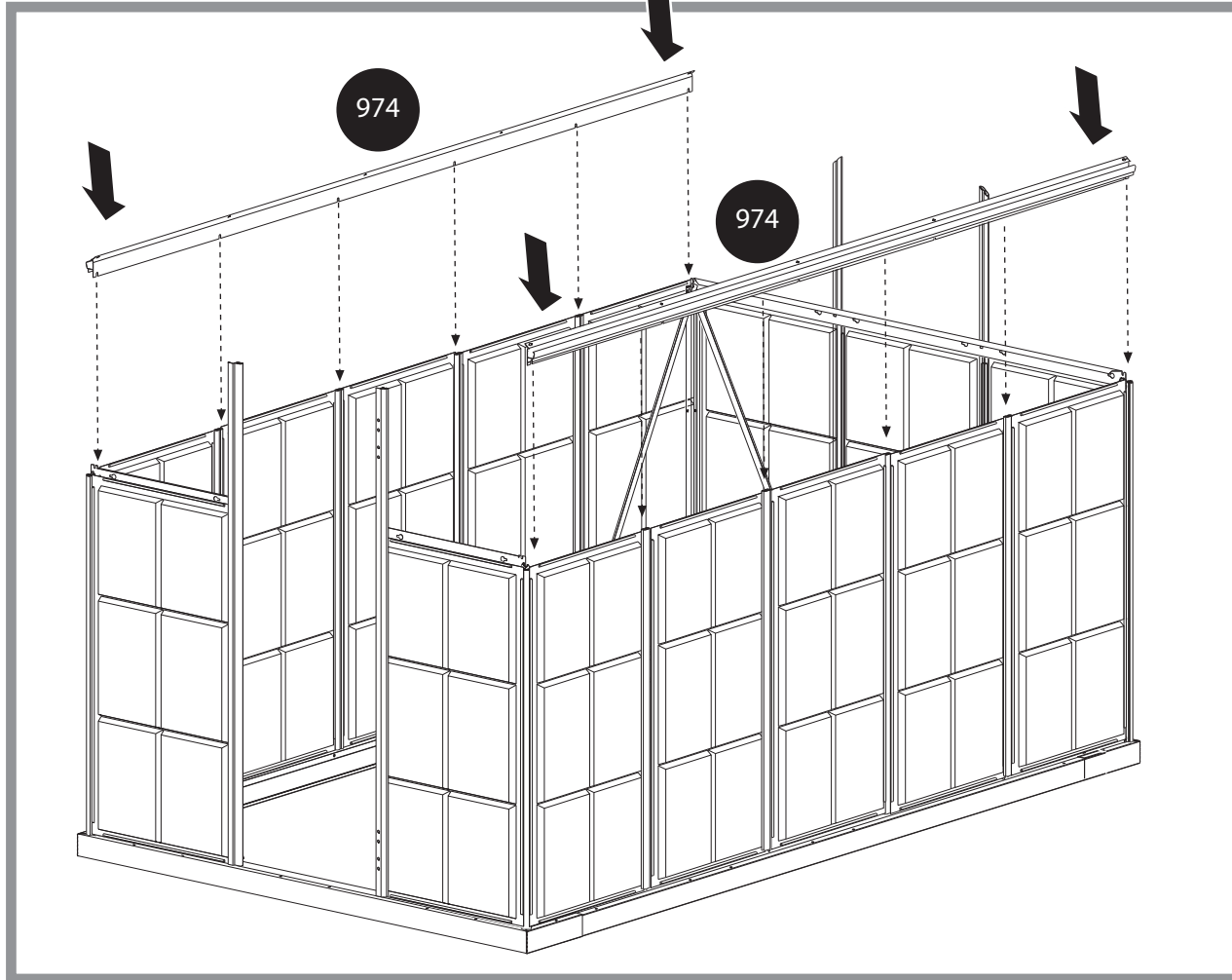
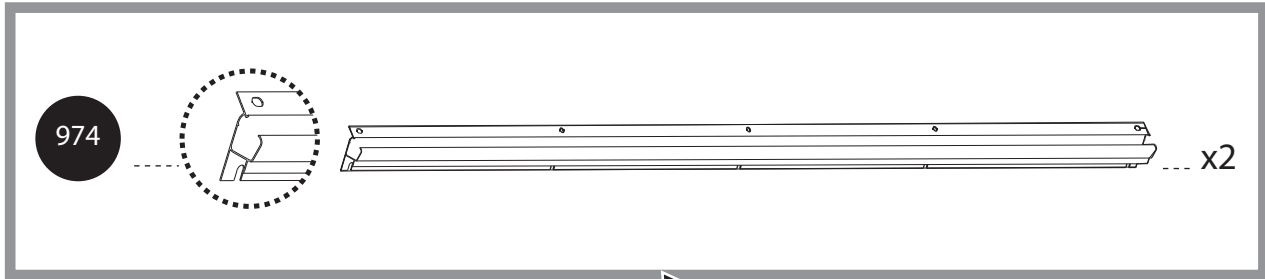
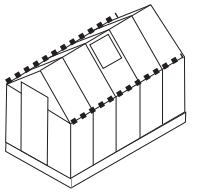

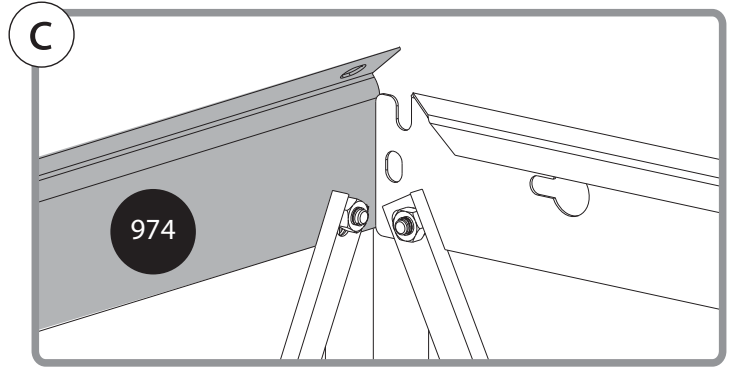
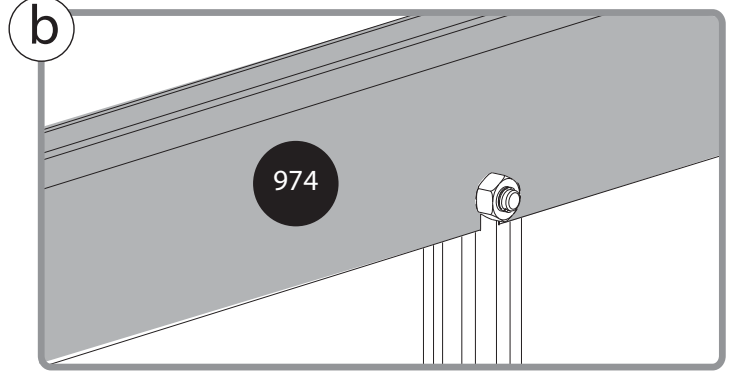
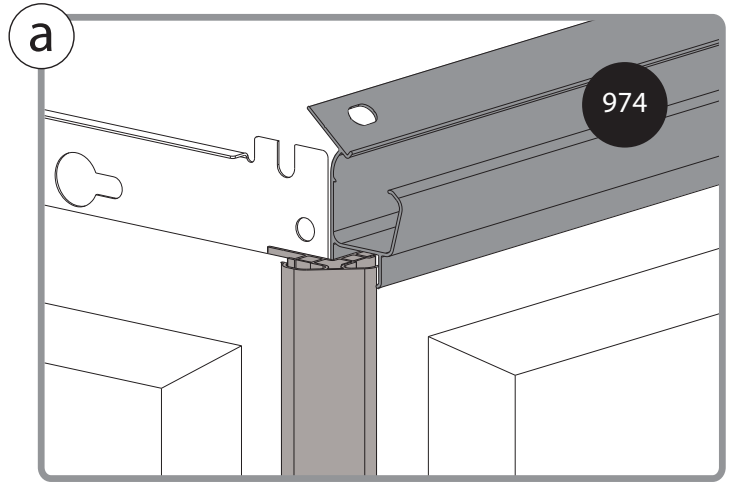
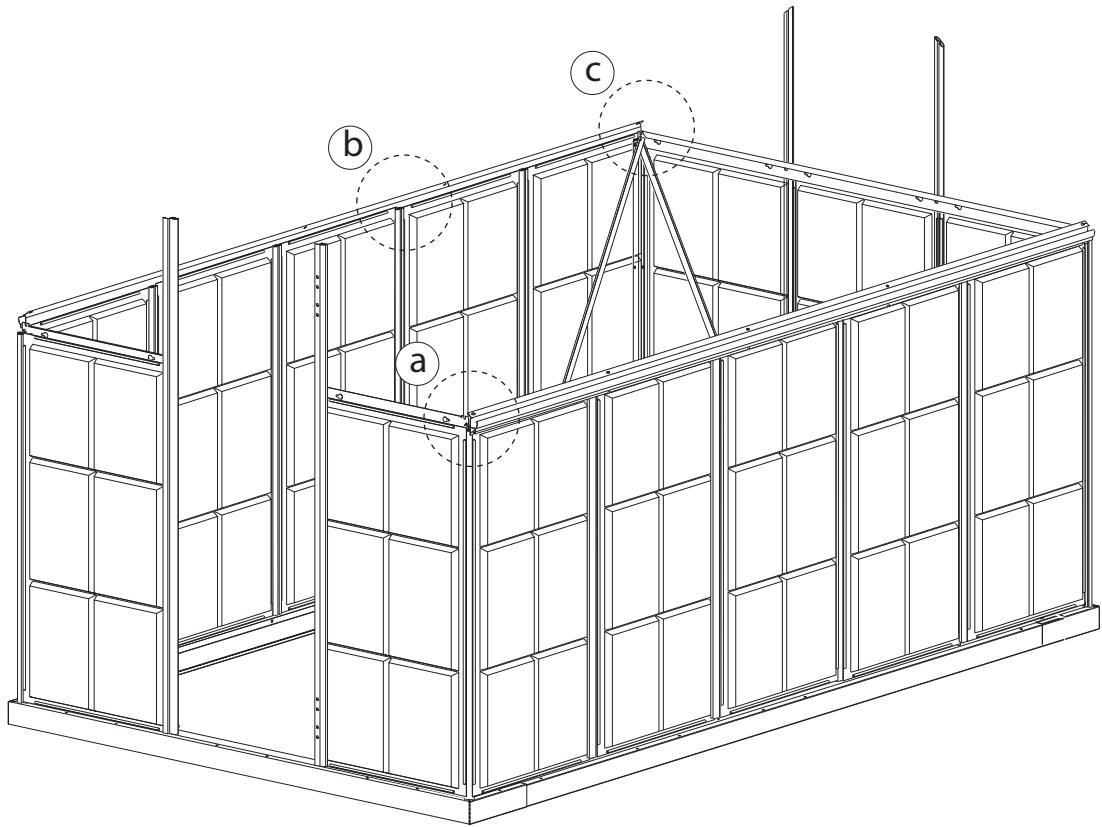
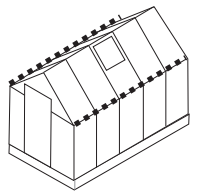

19

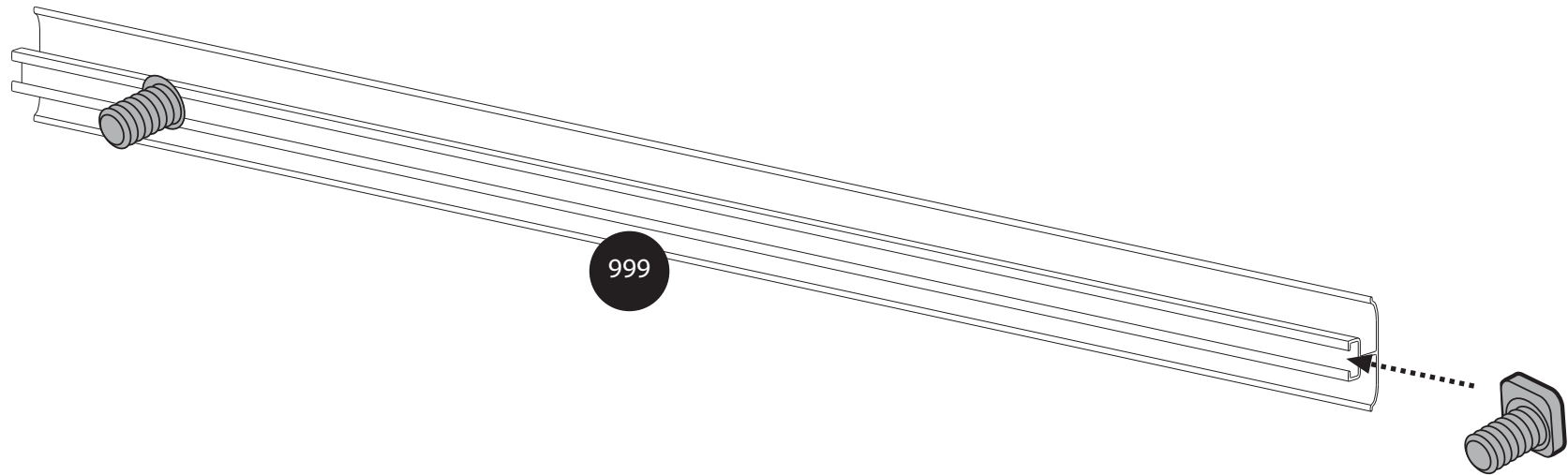
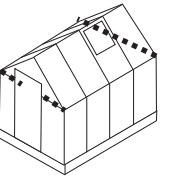

999

x5

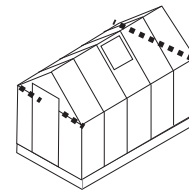

999

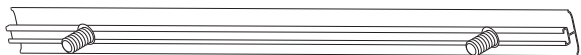

x5

412



x10

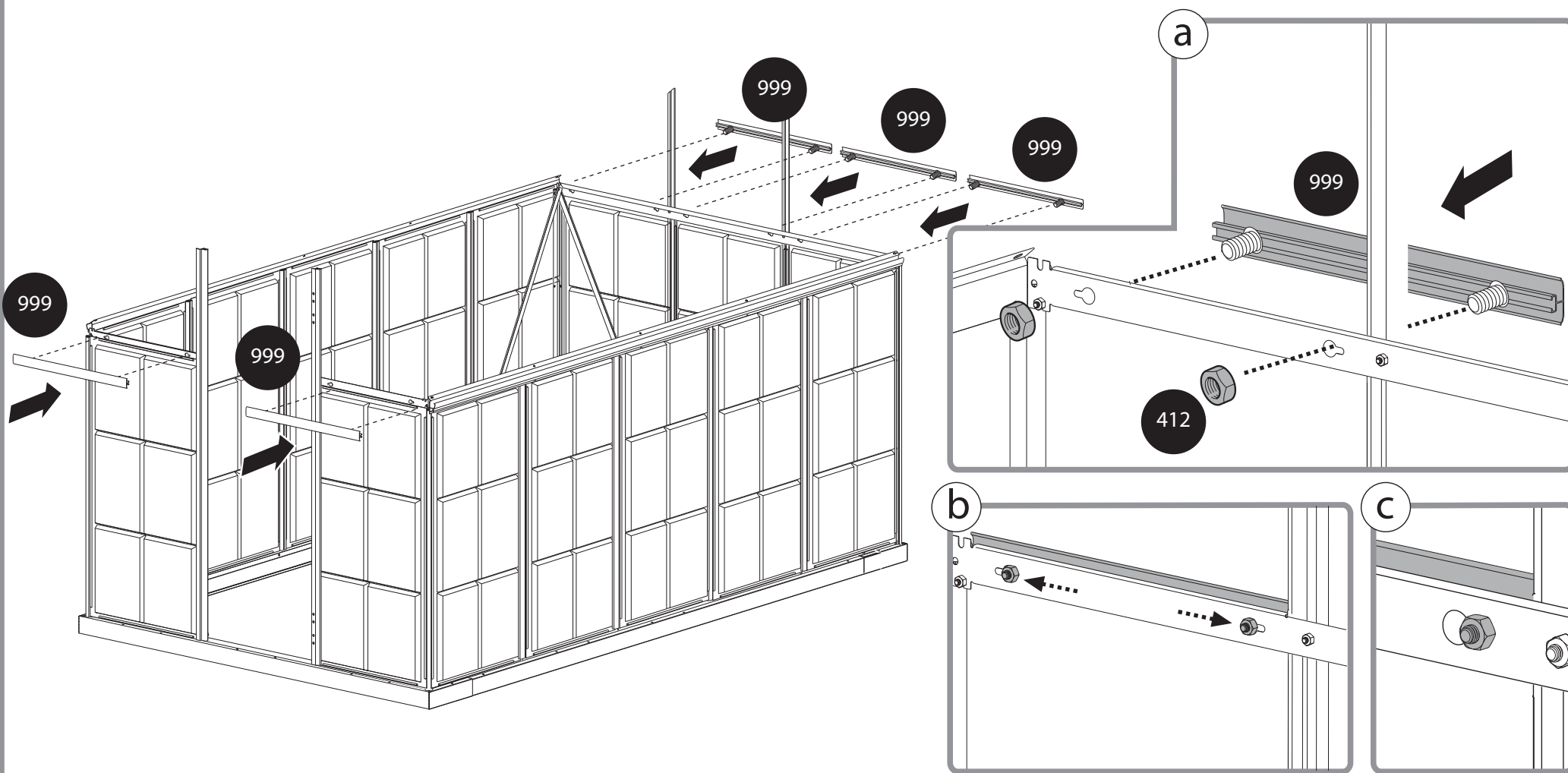

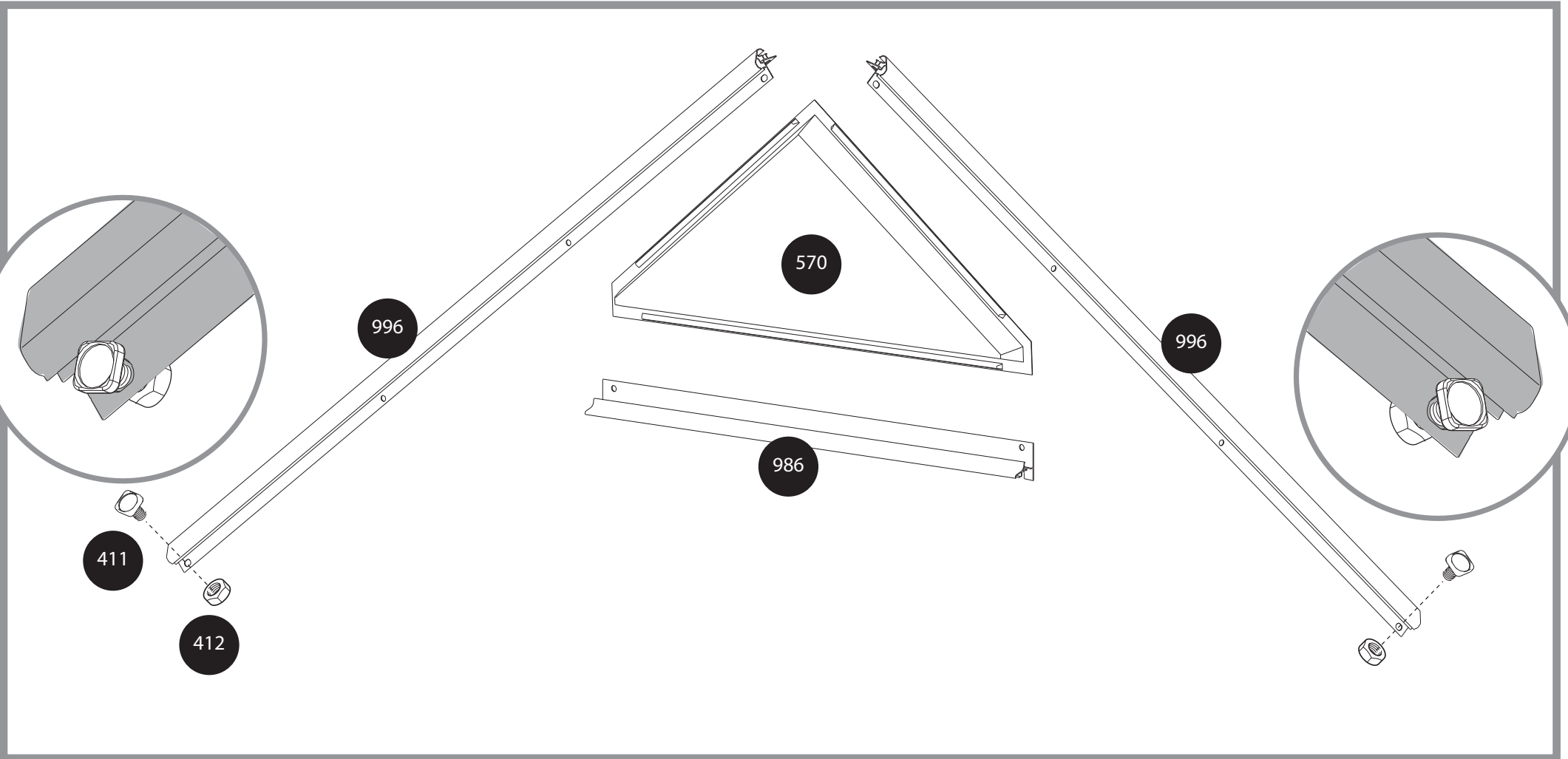
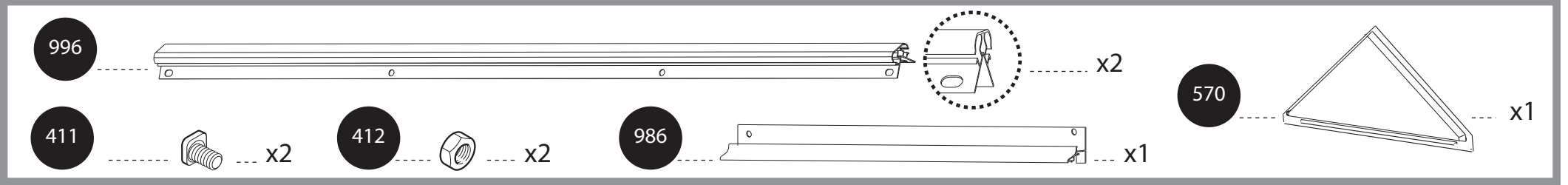
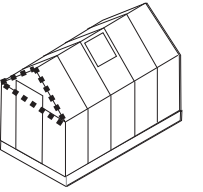

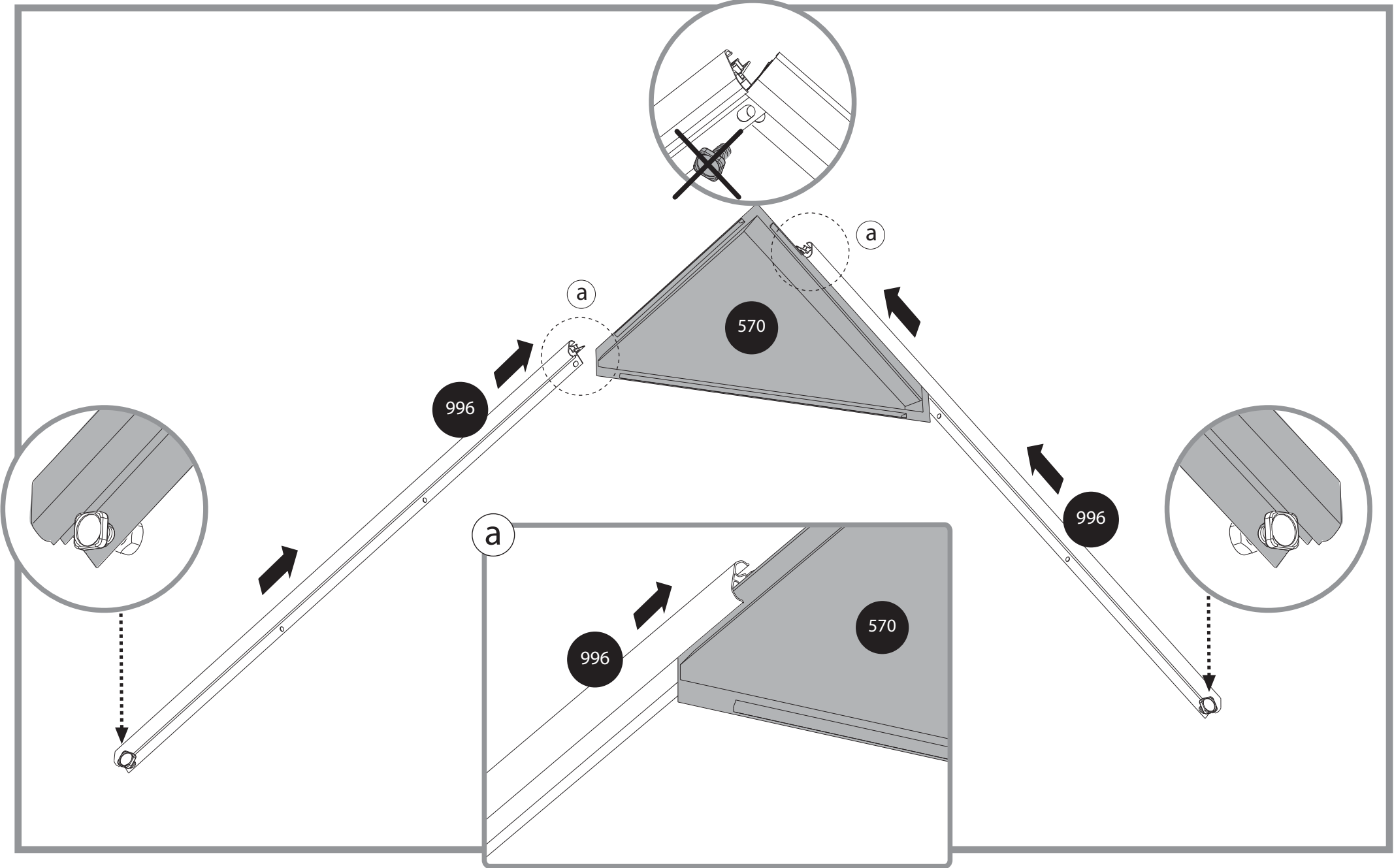
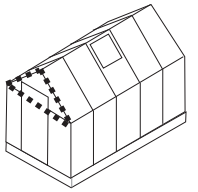

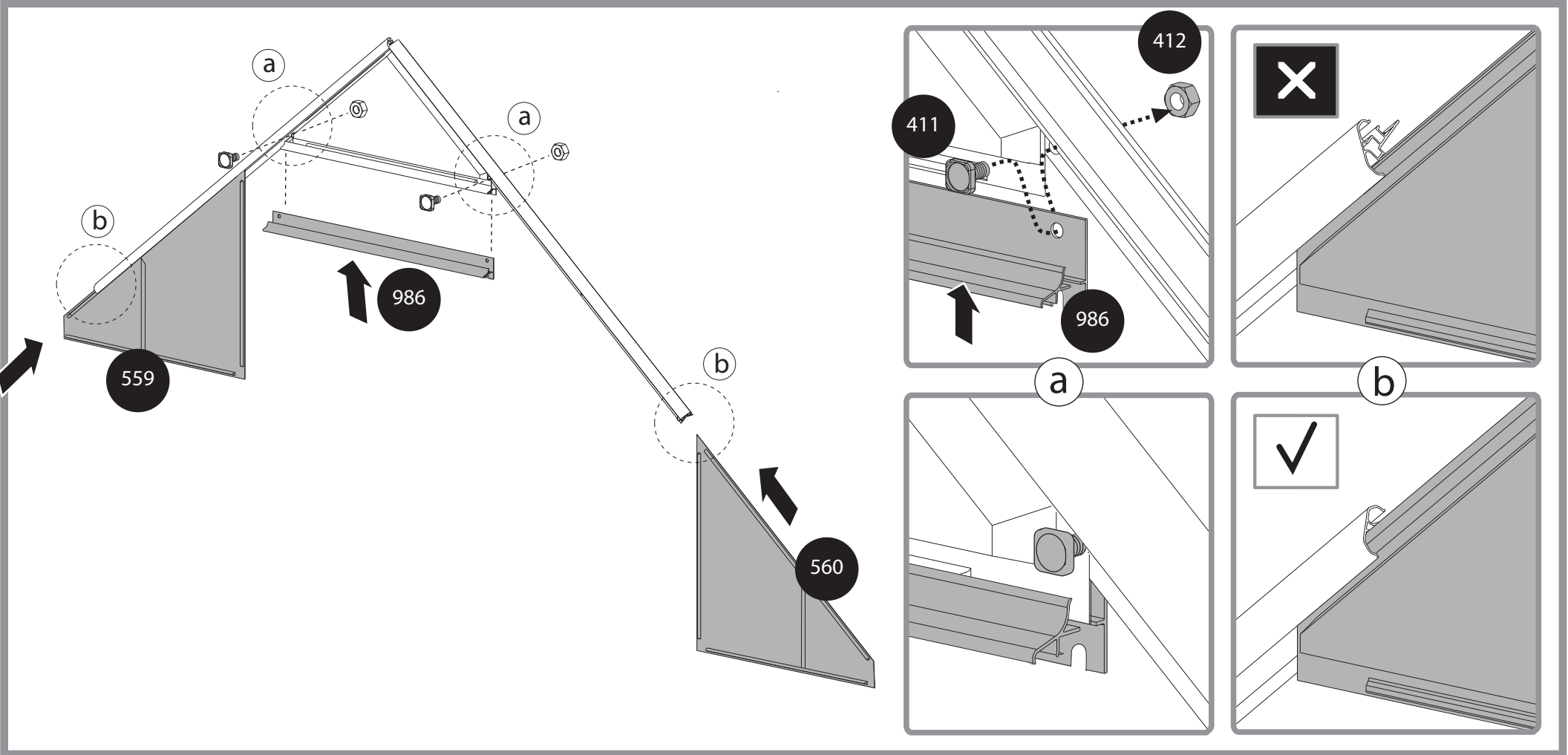
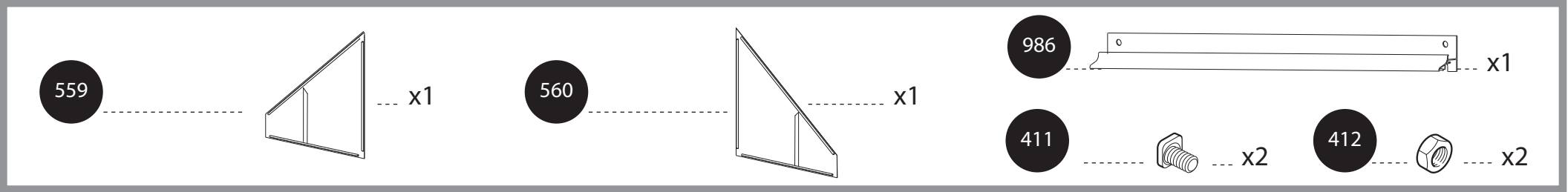
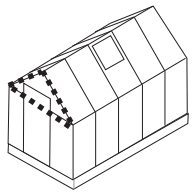

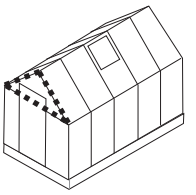

411

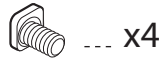

412

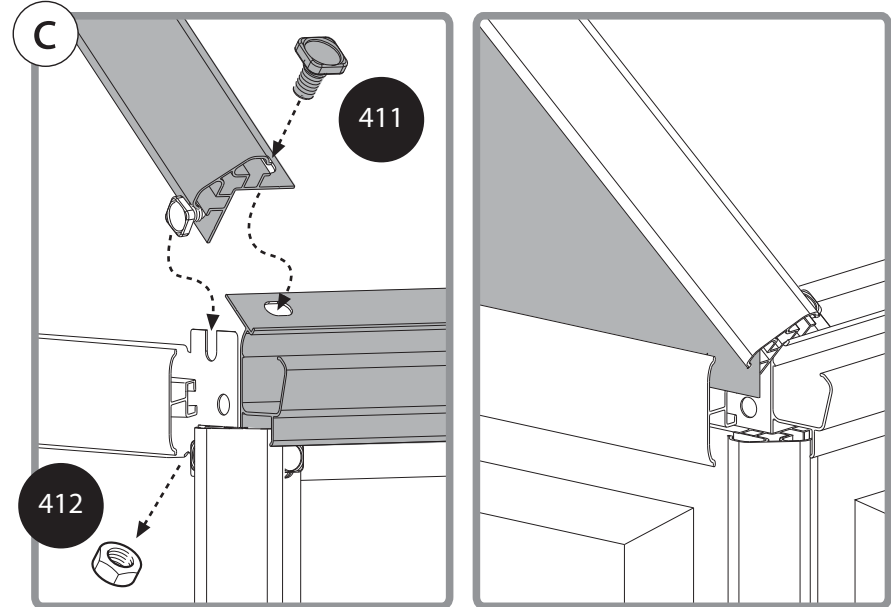
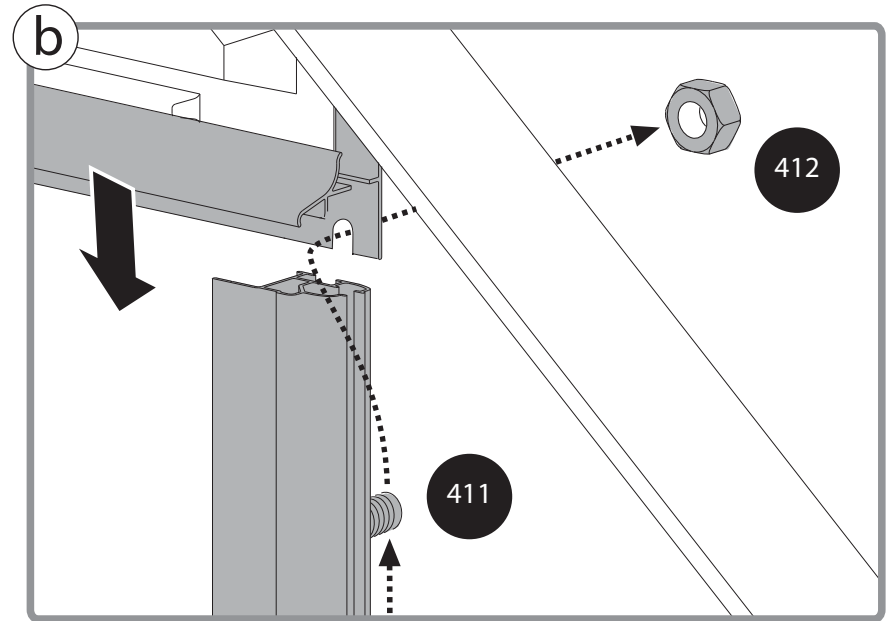
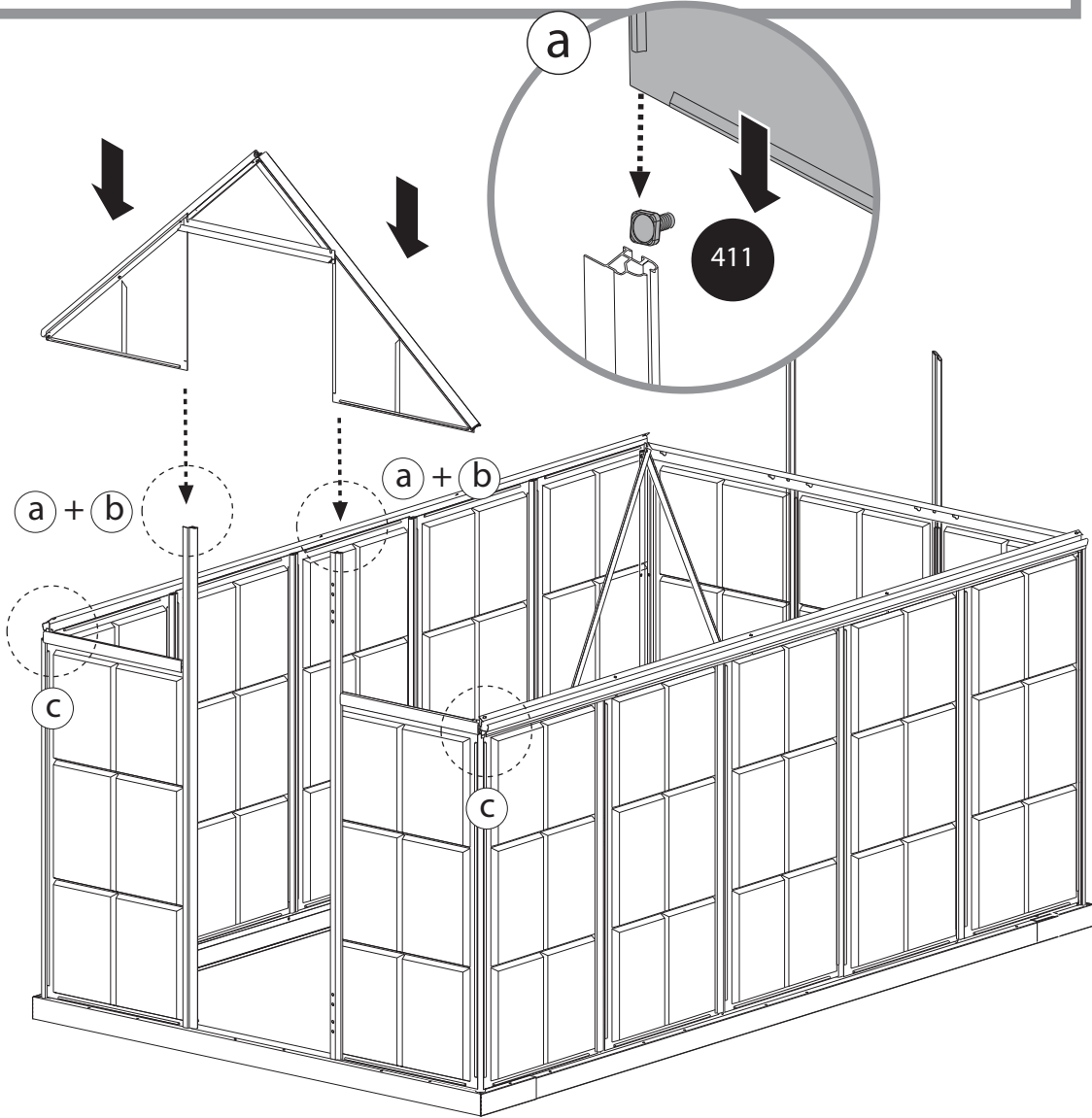

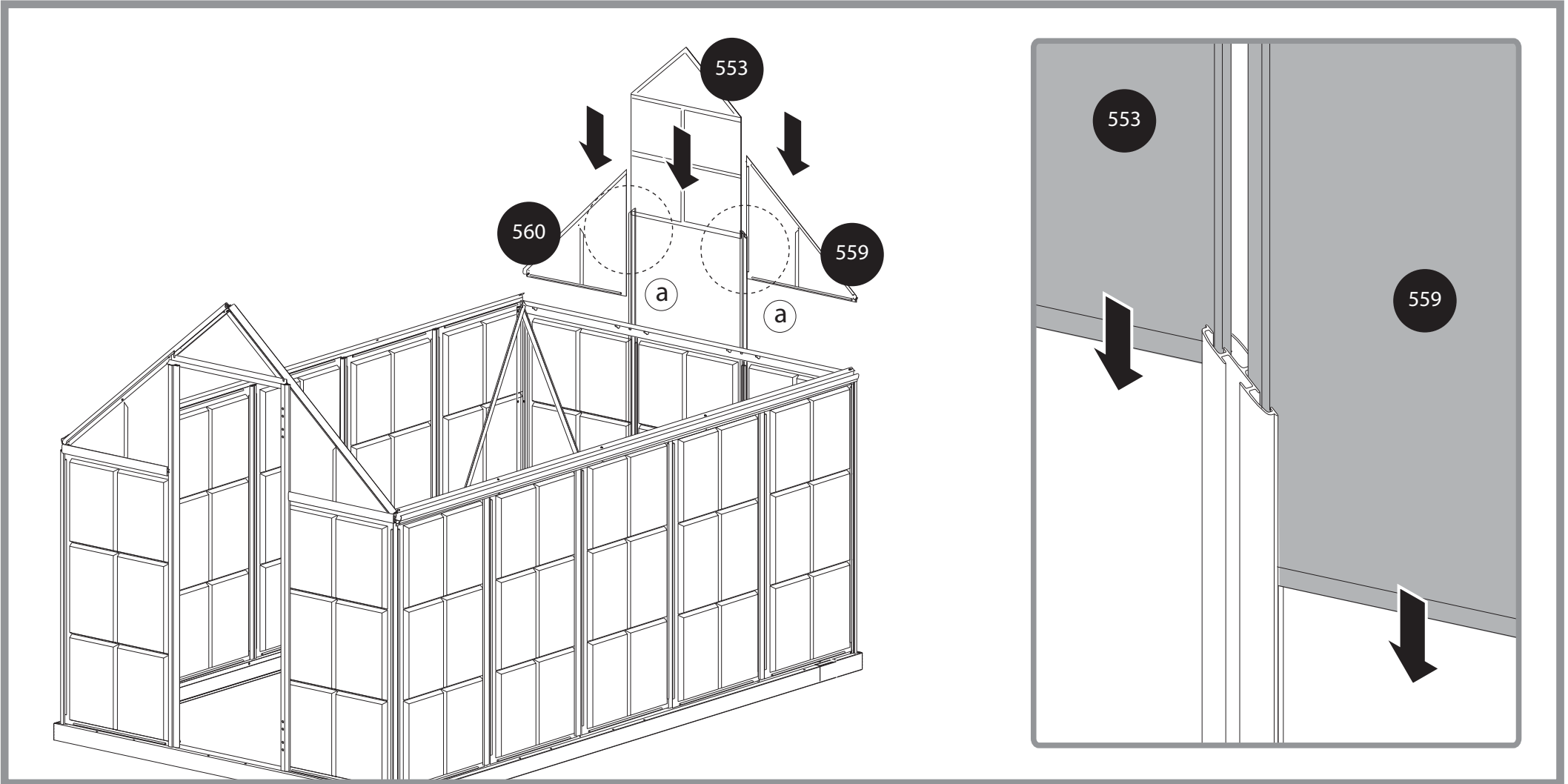
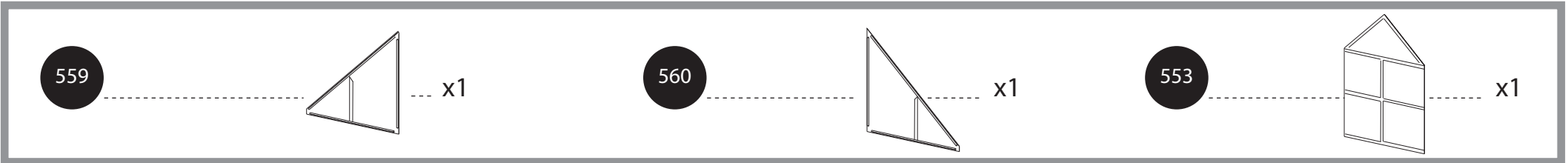
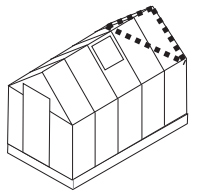

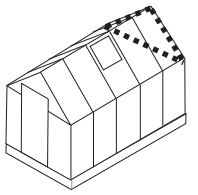

a

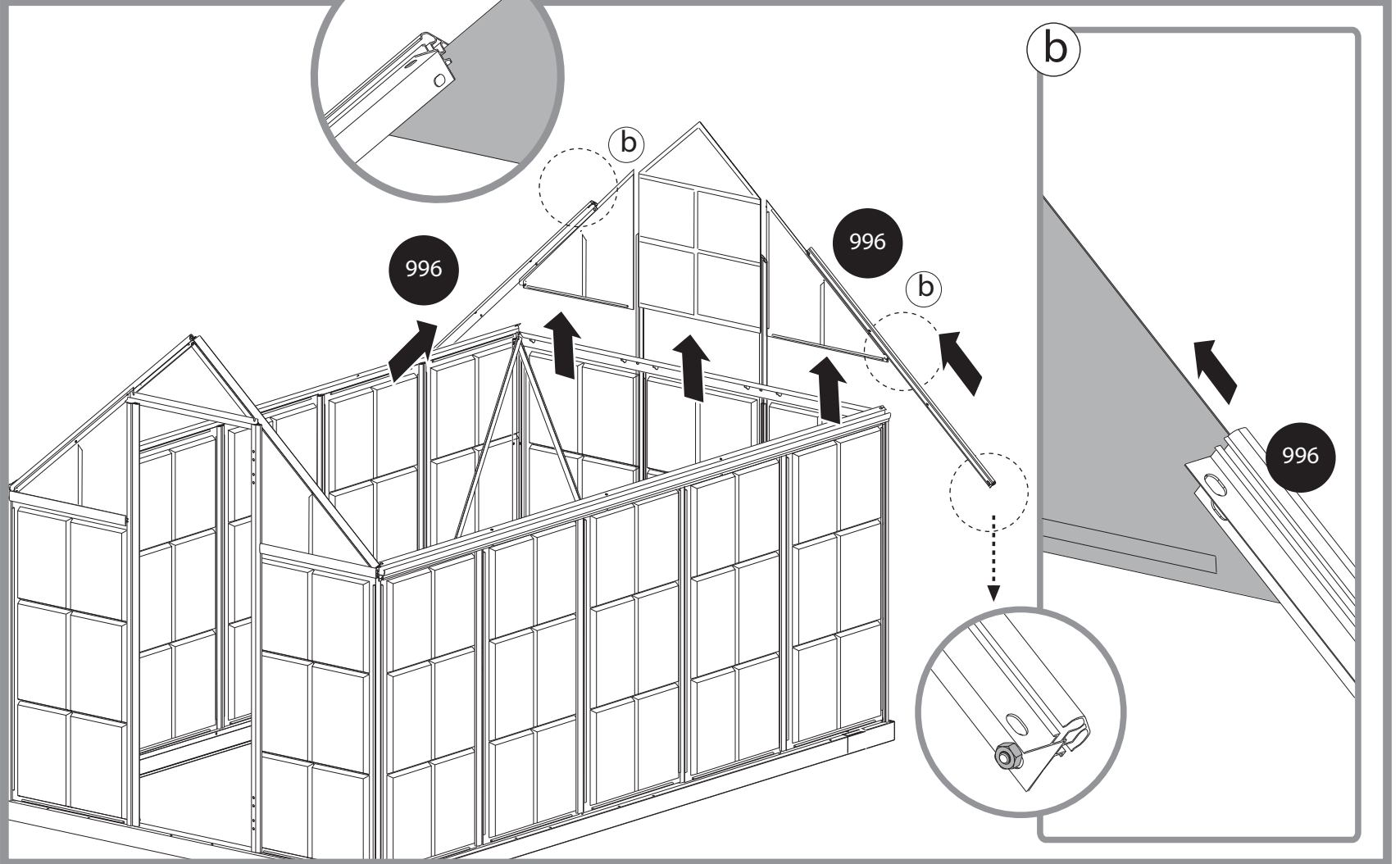
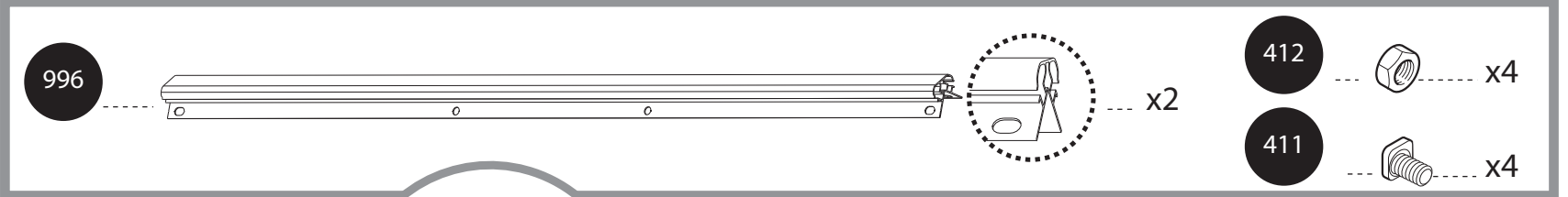
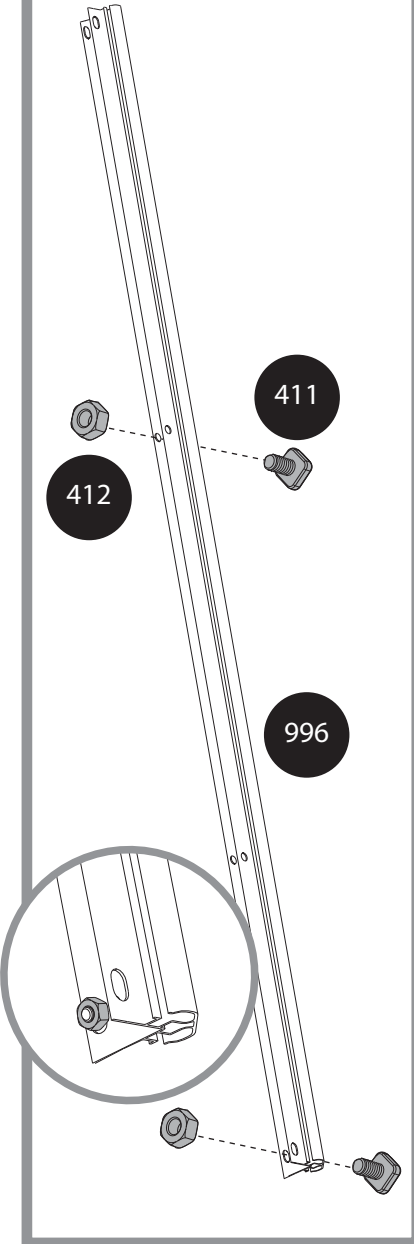

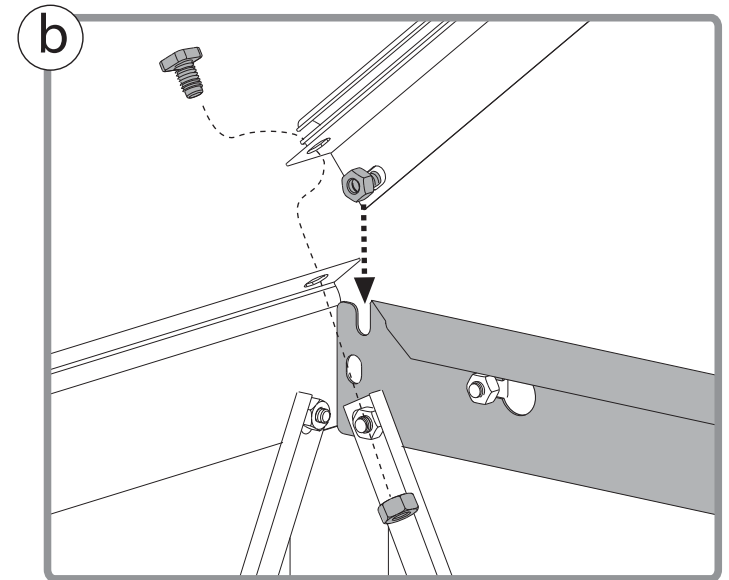
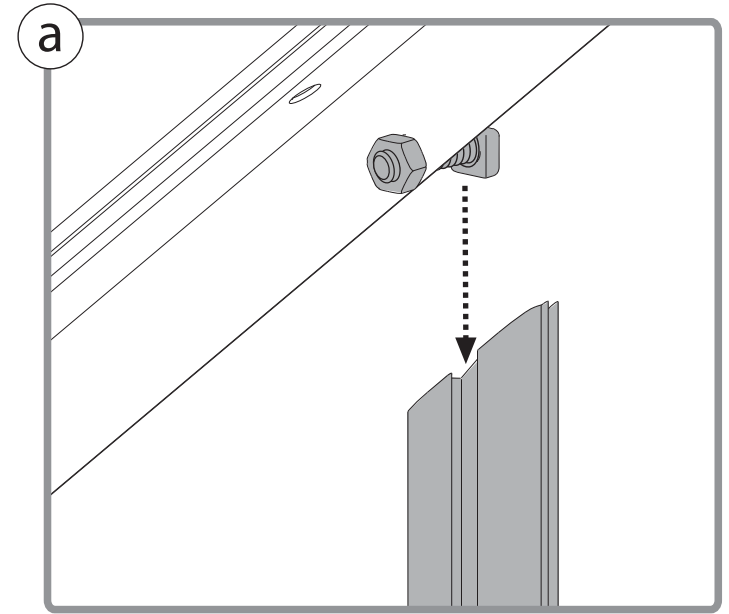
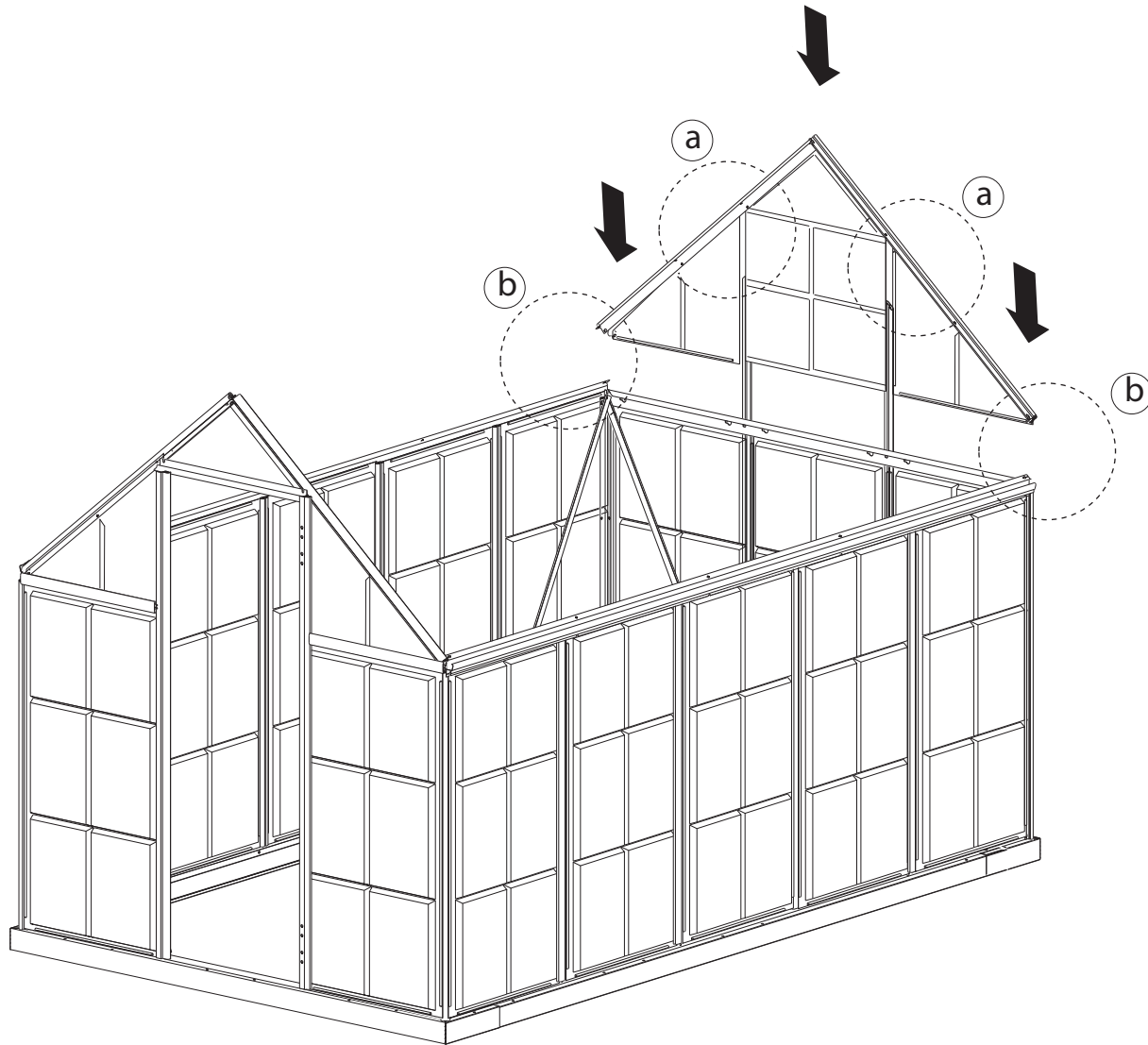
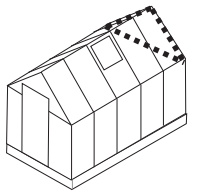

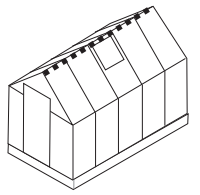

975



412 x4

411 x4

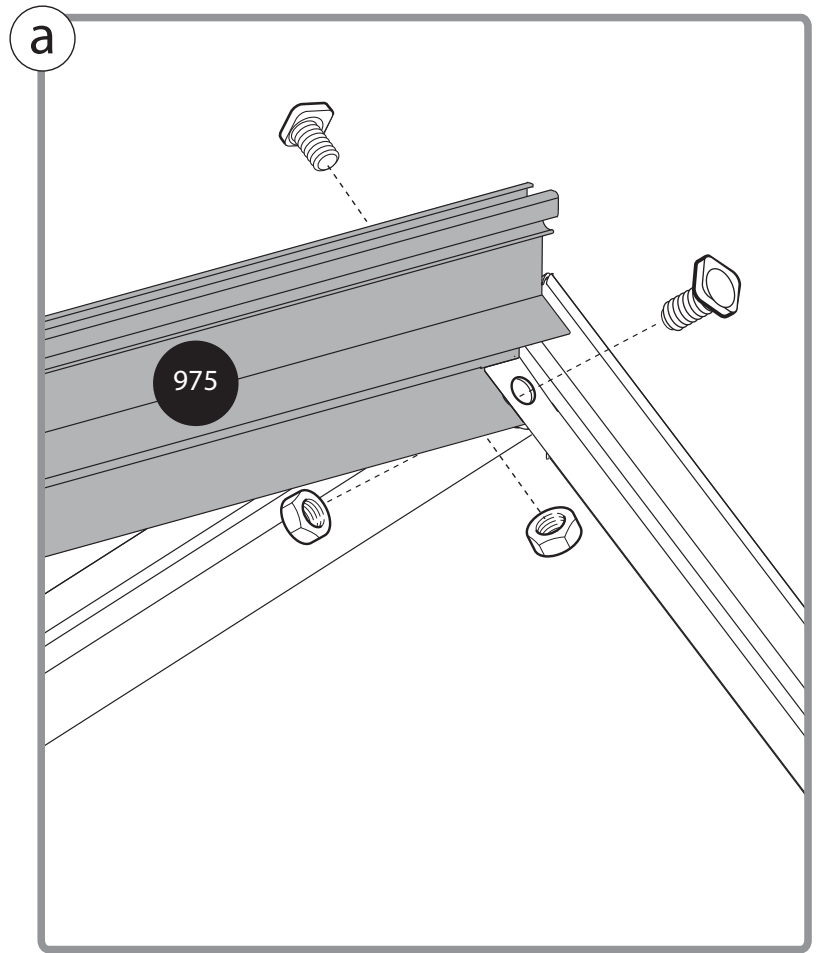
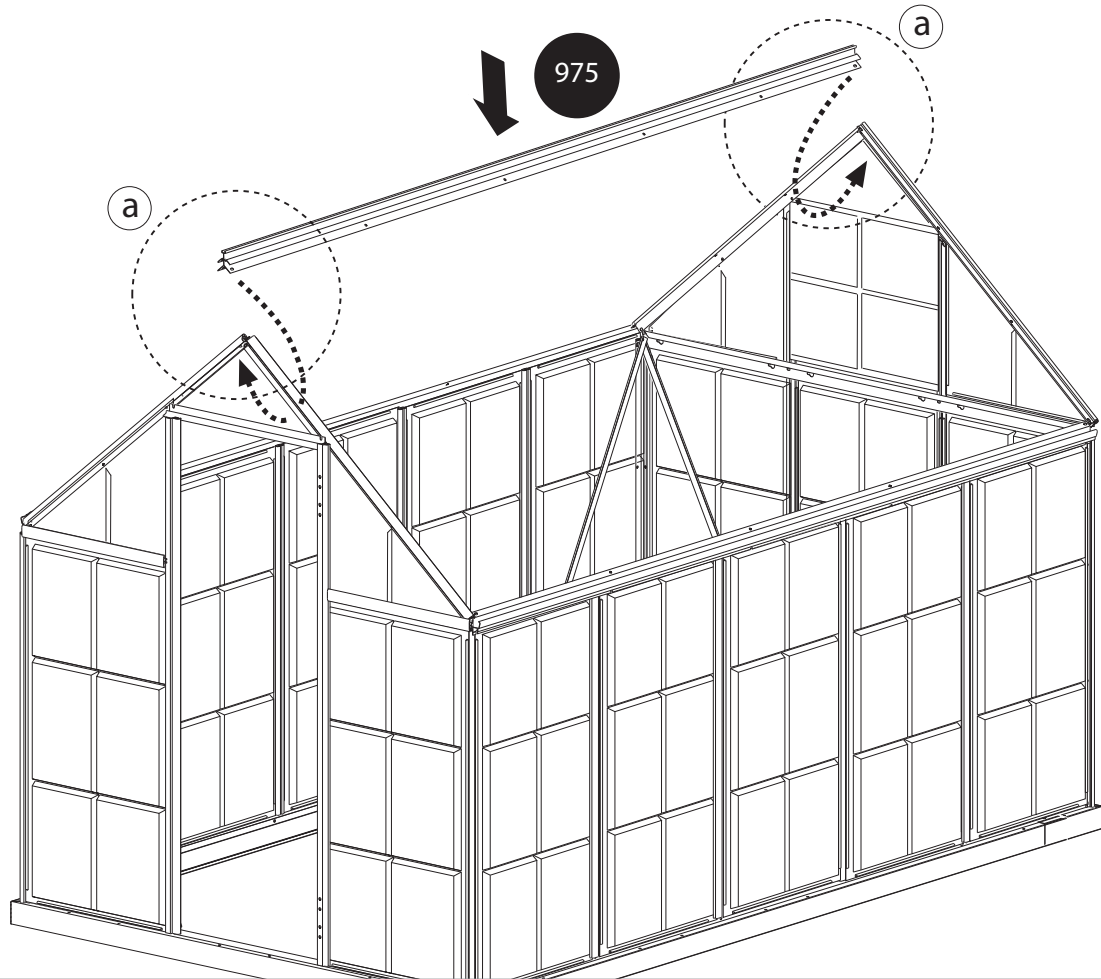

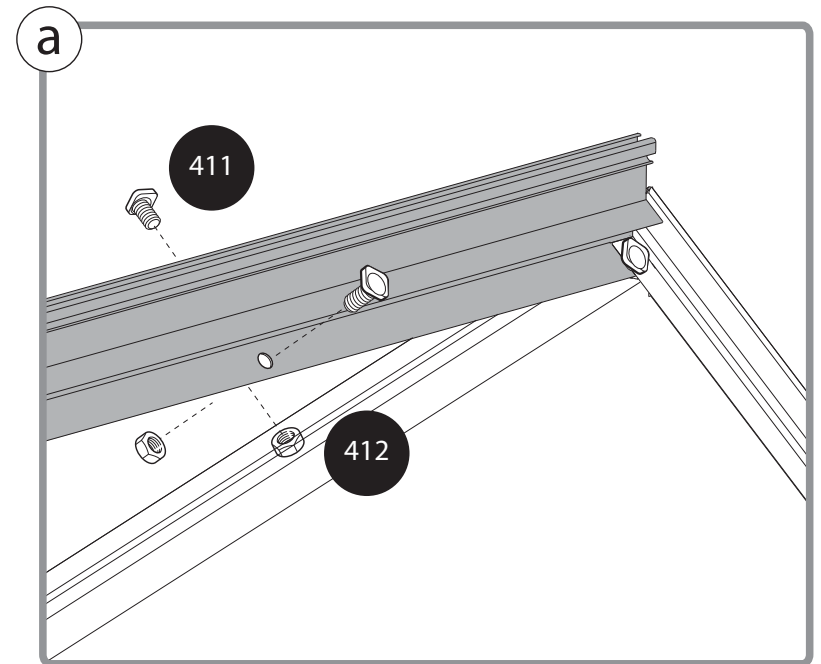
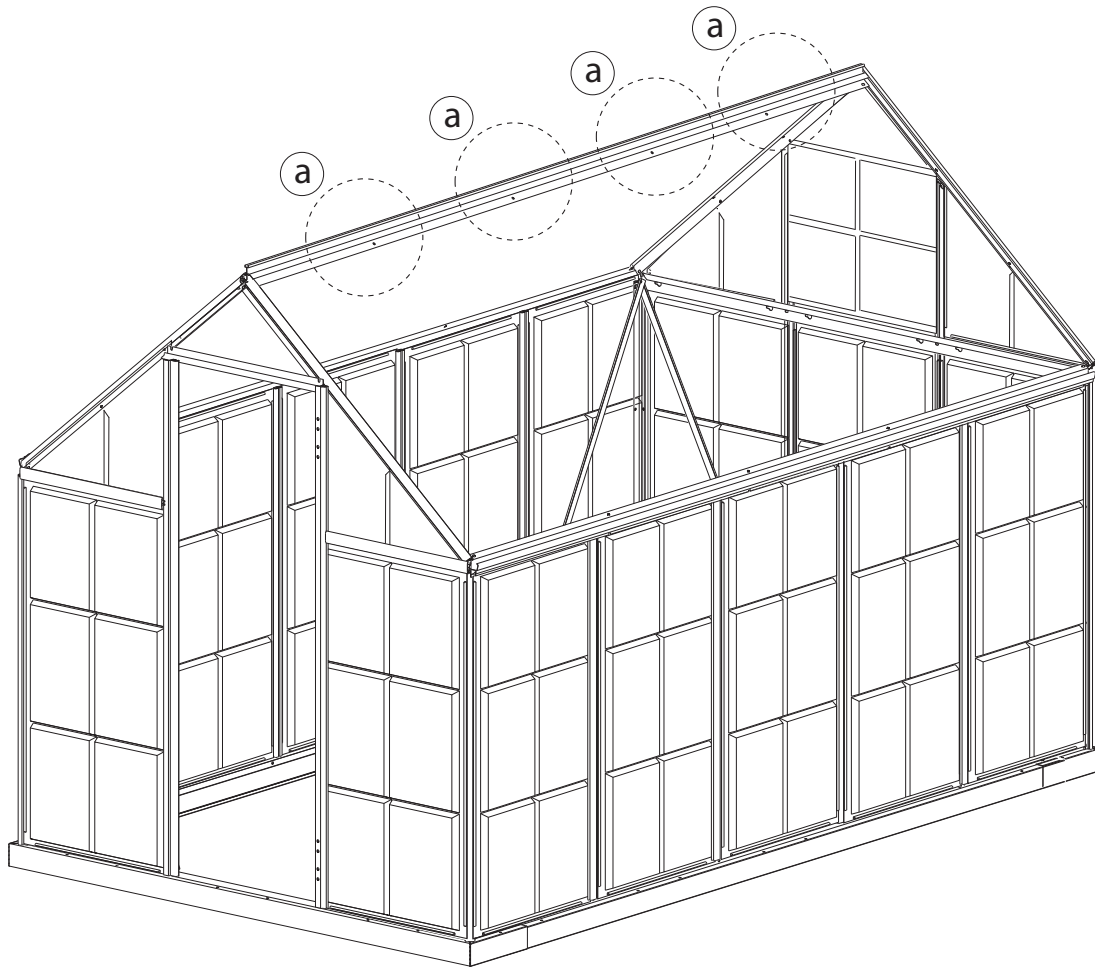
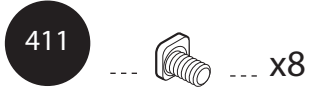
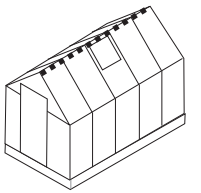

EN Window Location
GR Fenster Standort
FR Fenêtre Emplacement
SP Ventana Ubicación

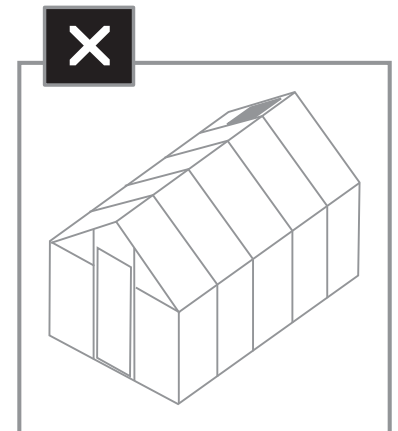
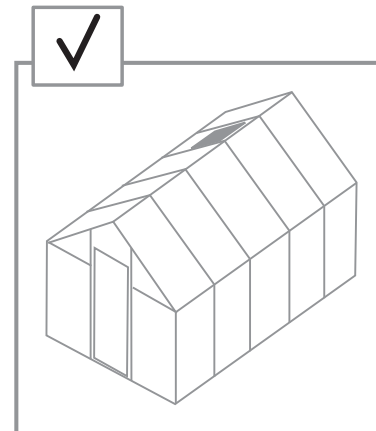
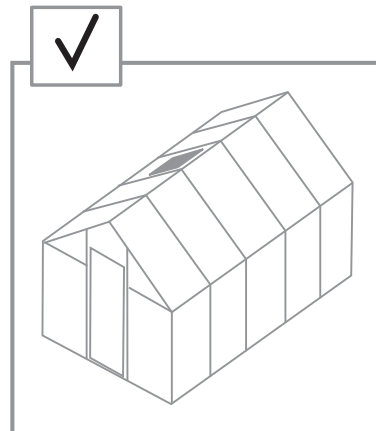
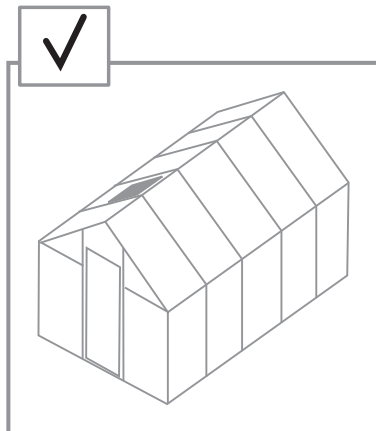
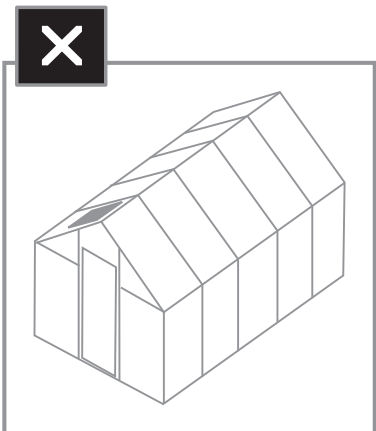
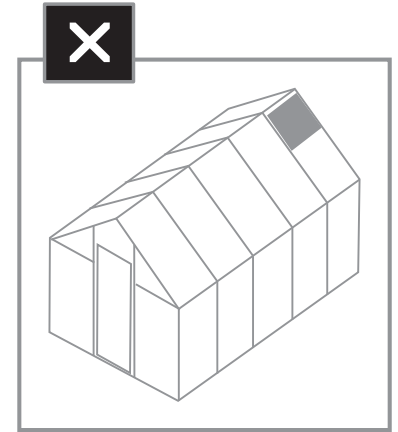
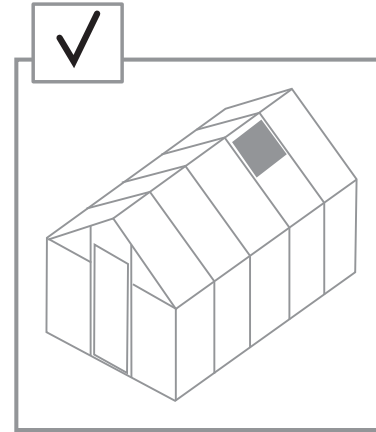
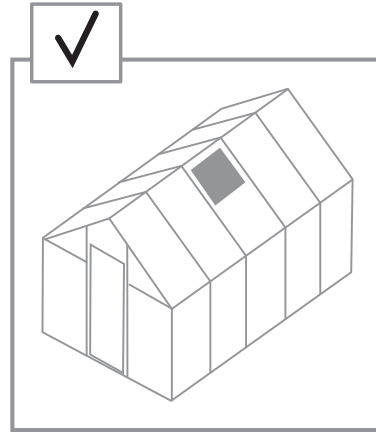
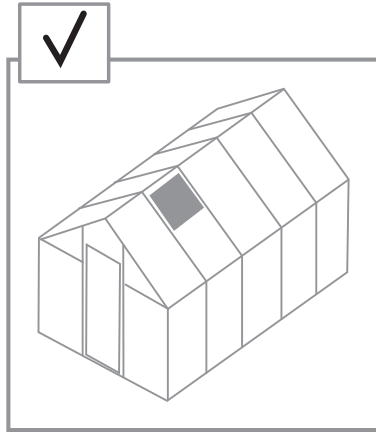
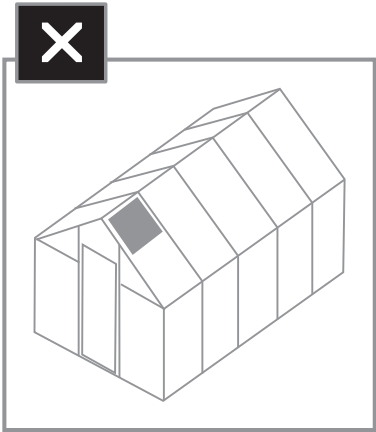
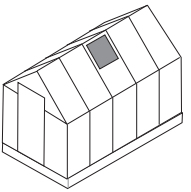

31

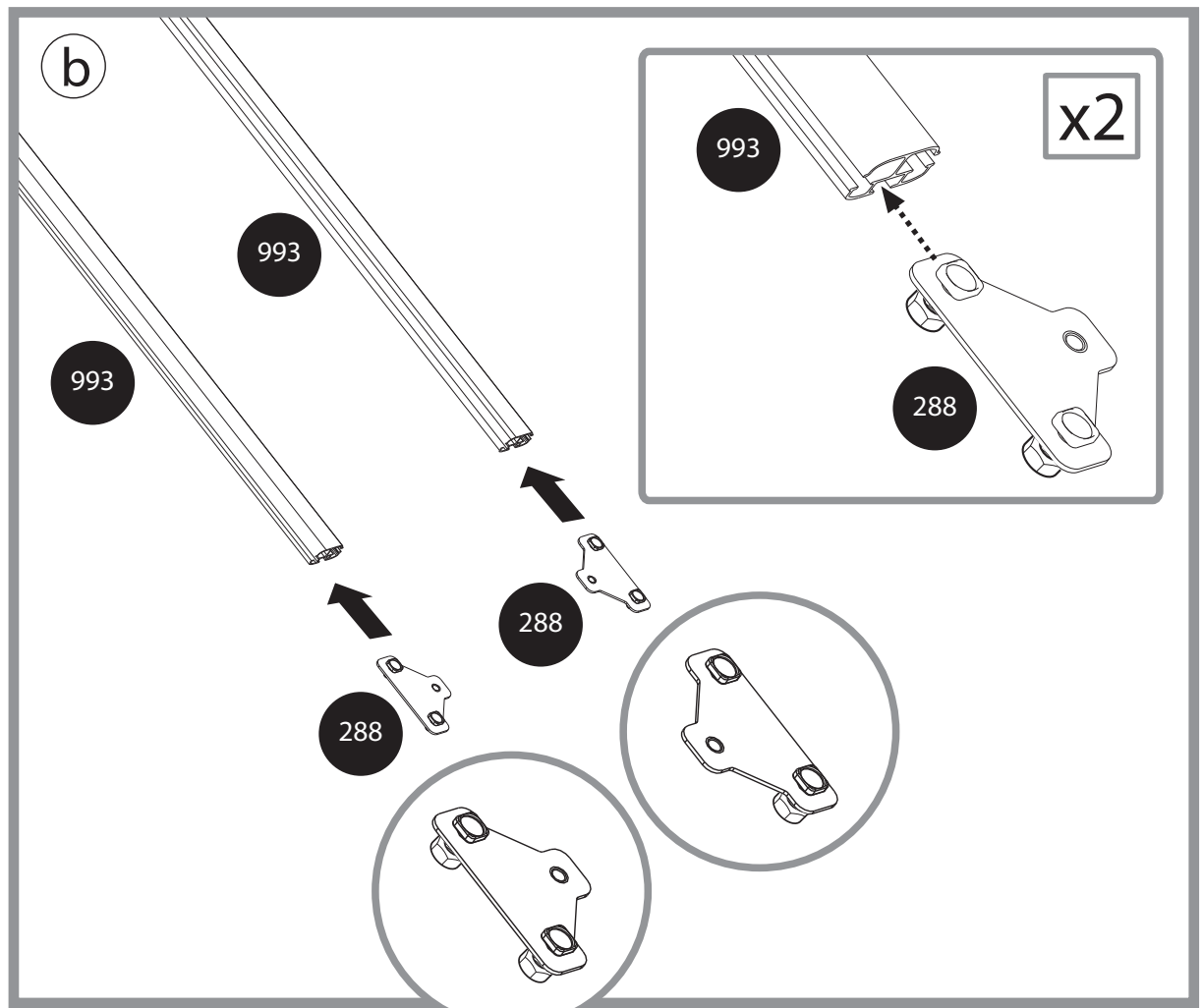
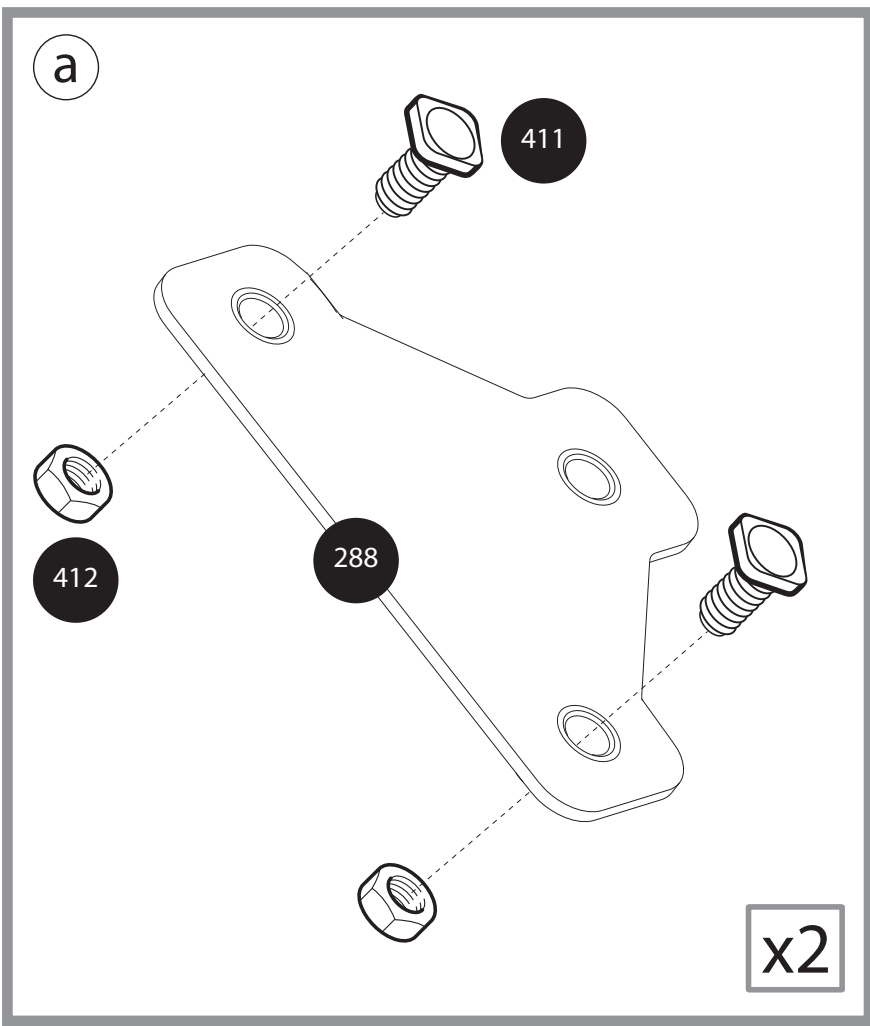
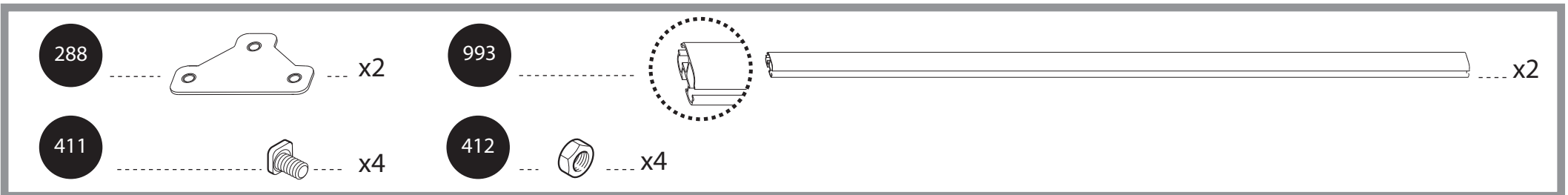
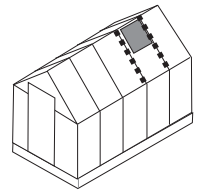

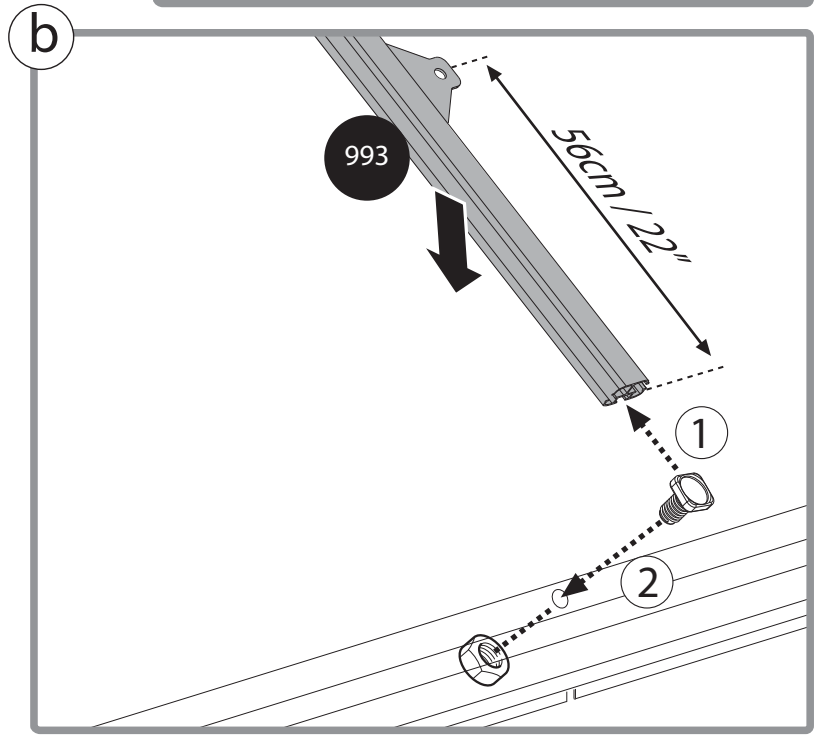
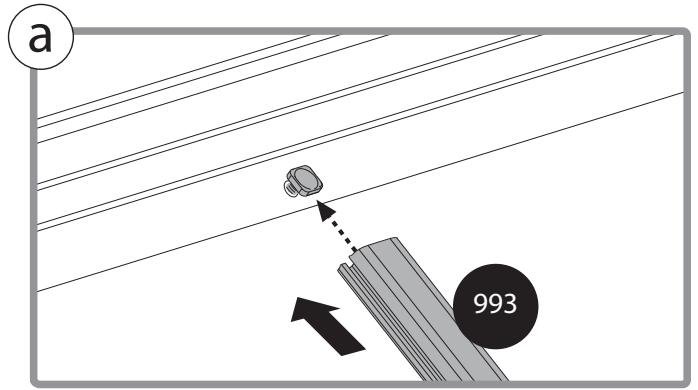
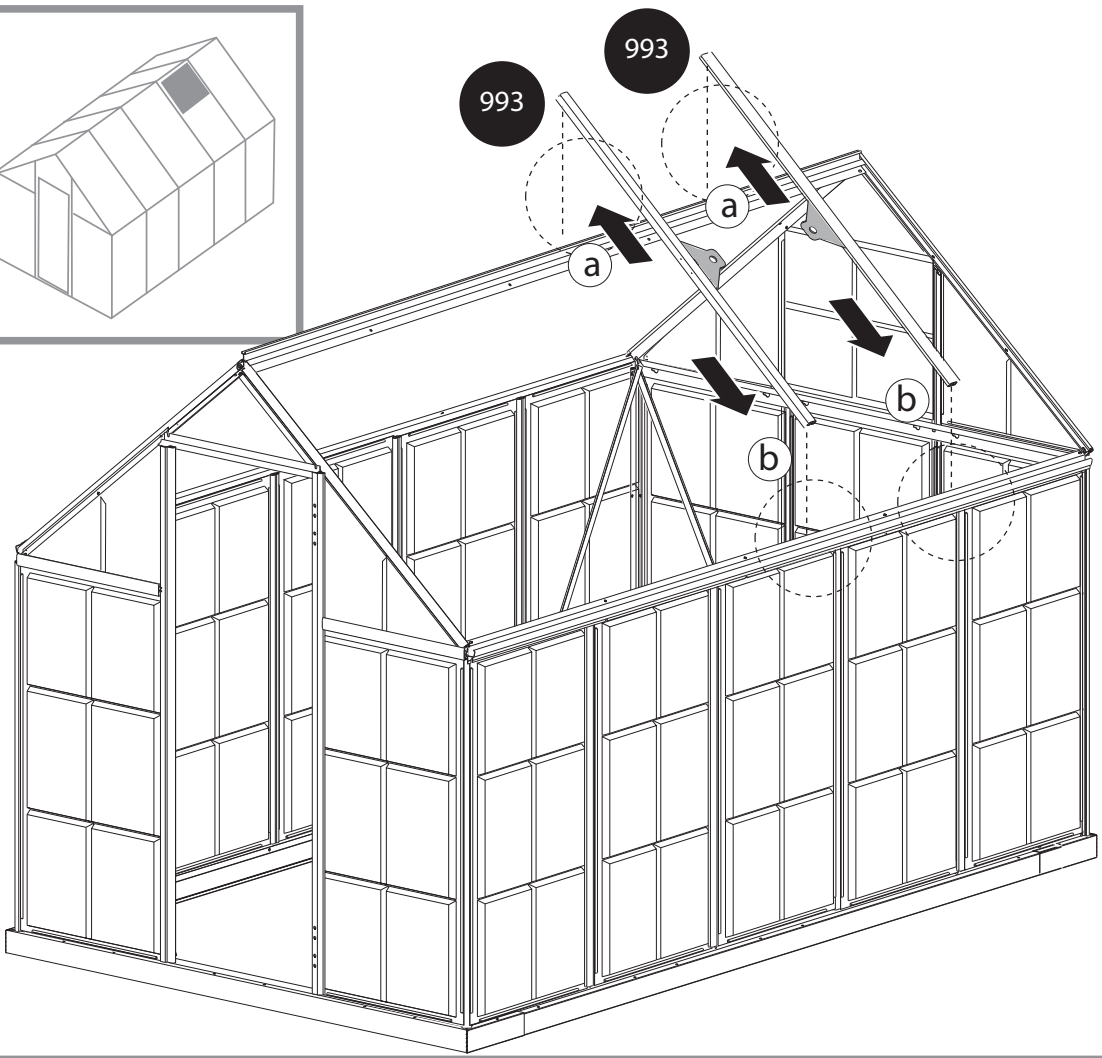
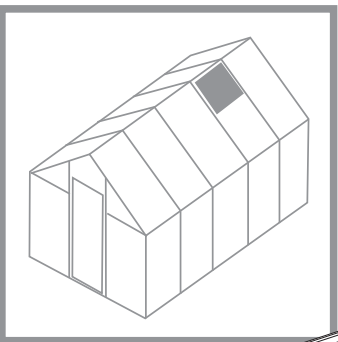
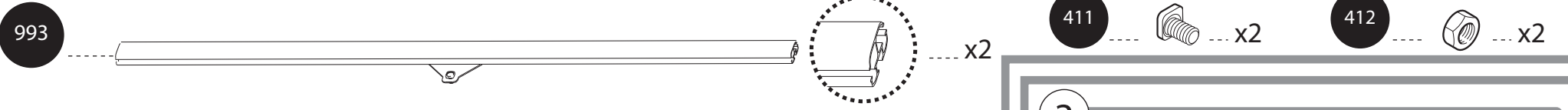
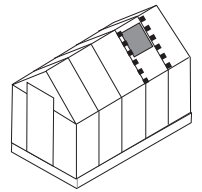

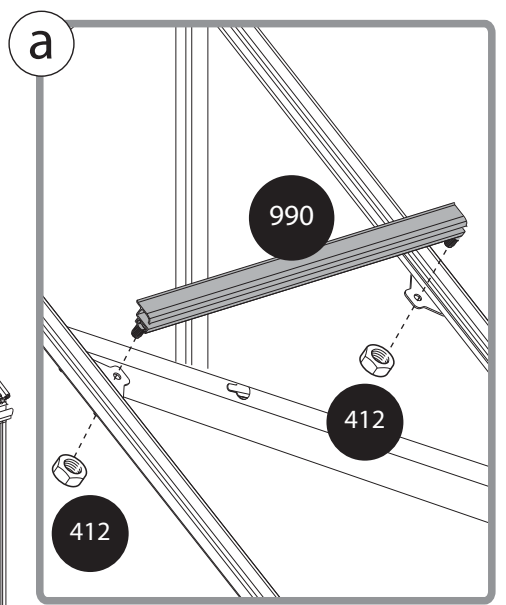
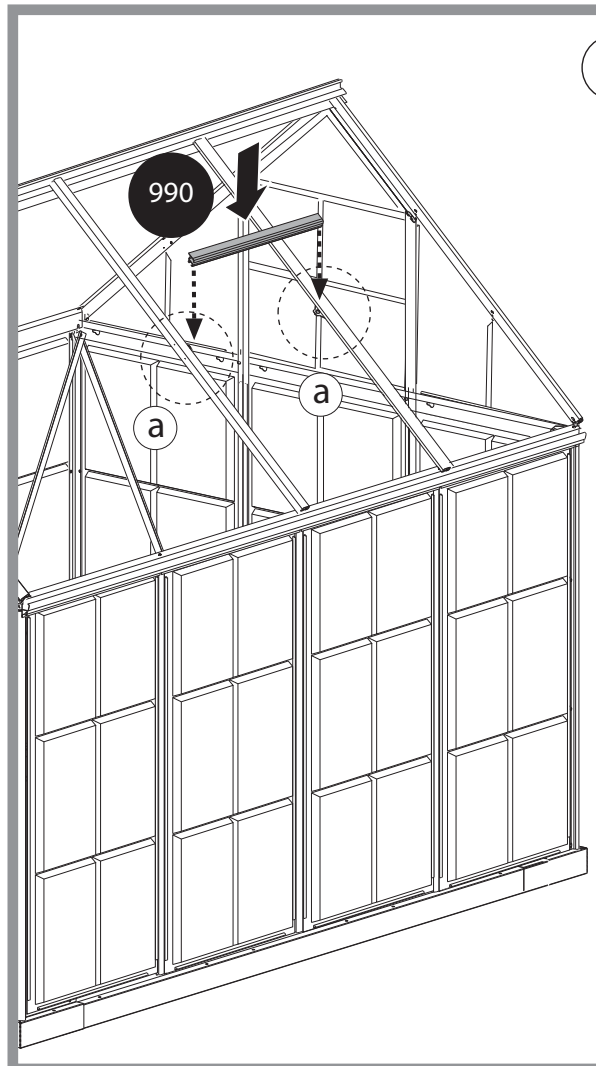
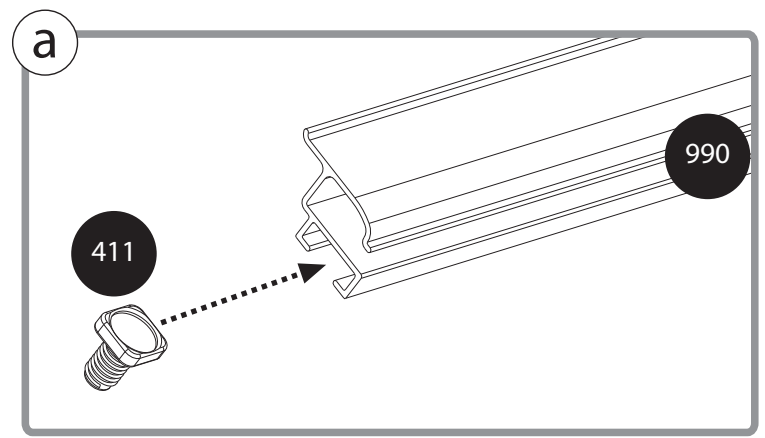
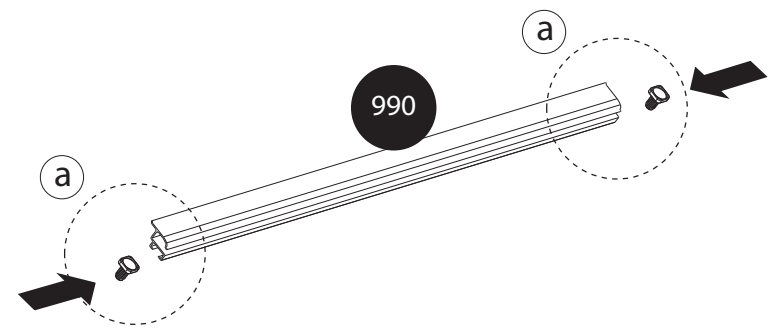
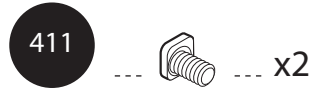
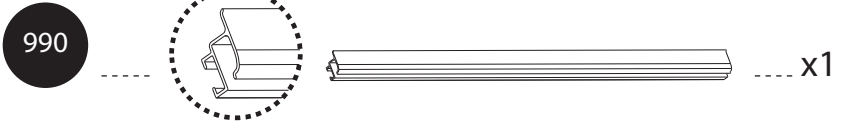
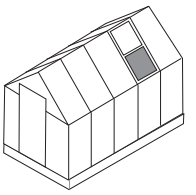

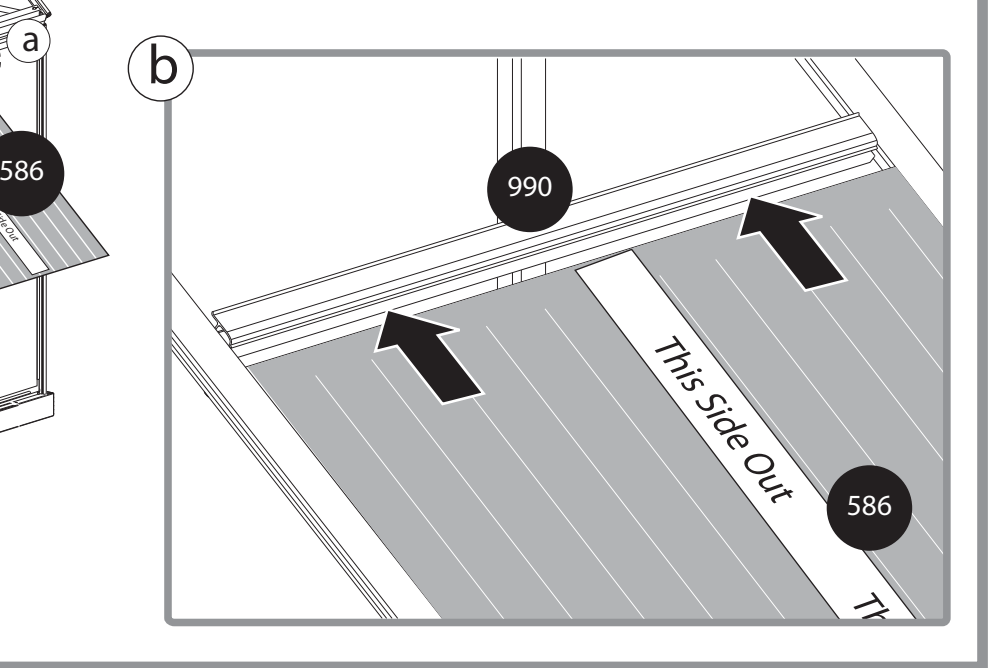
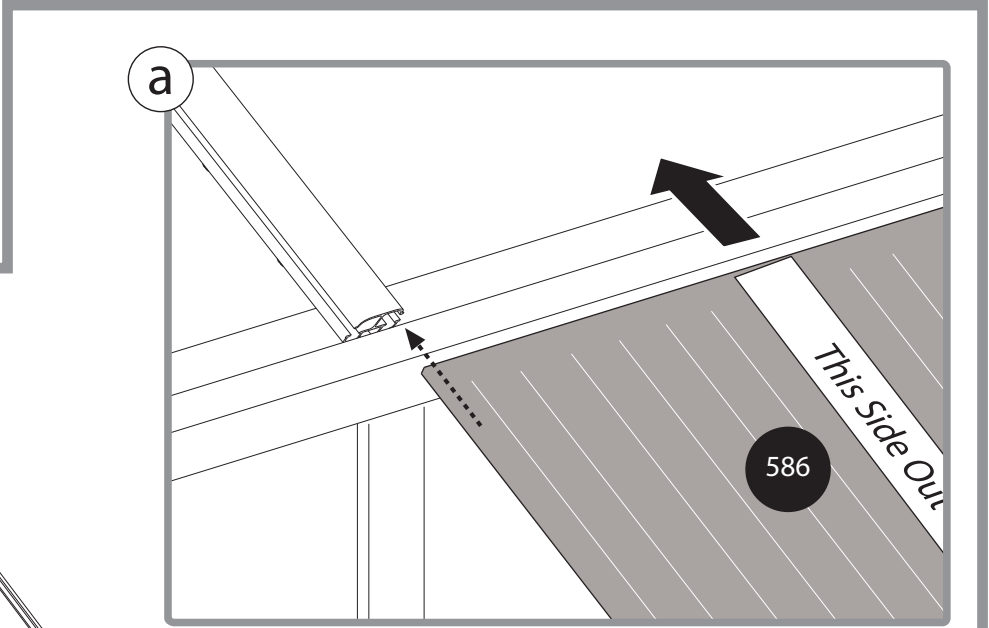
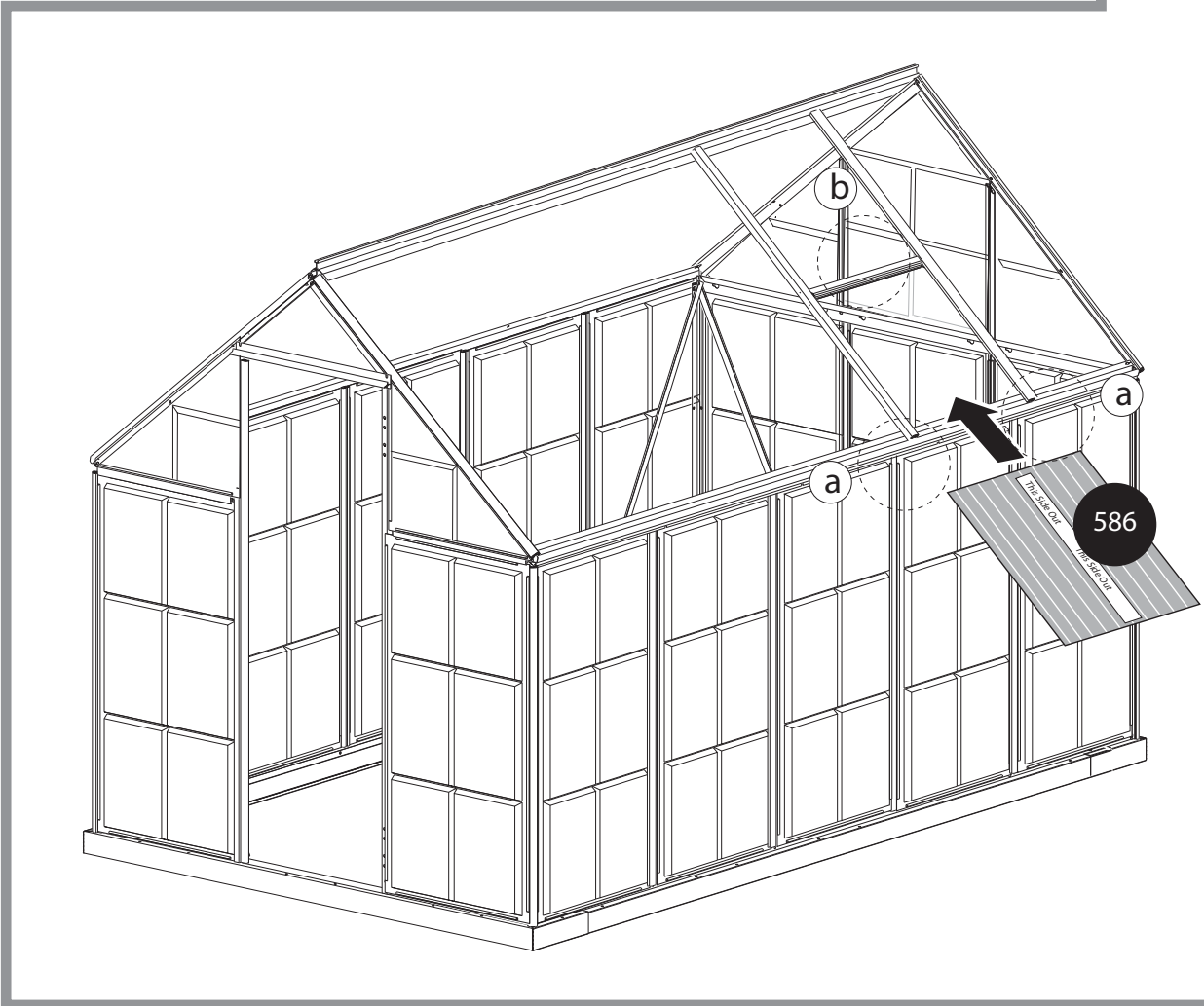
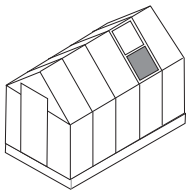

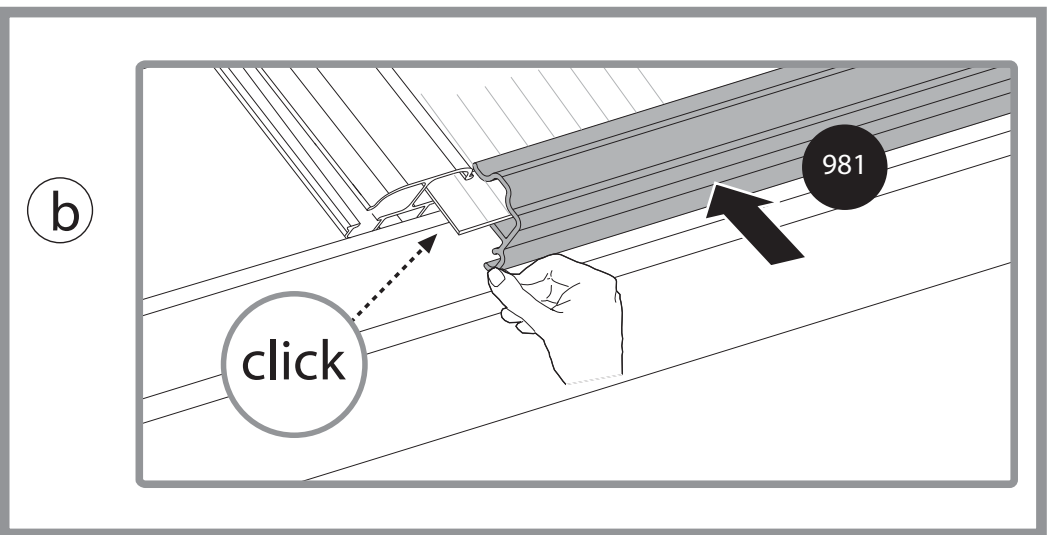
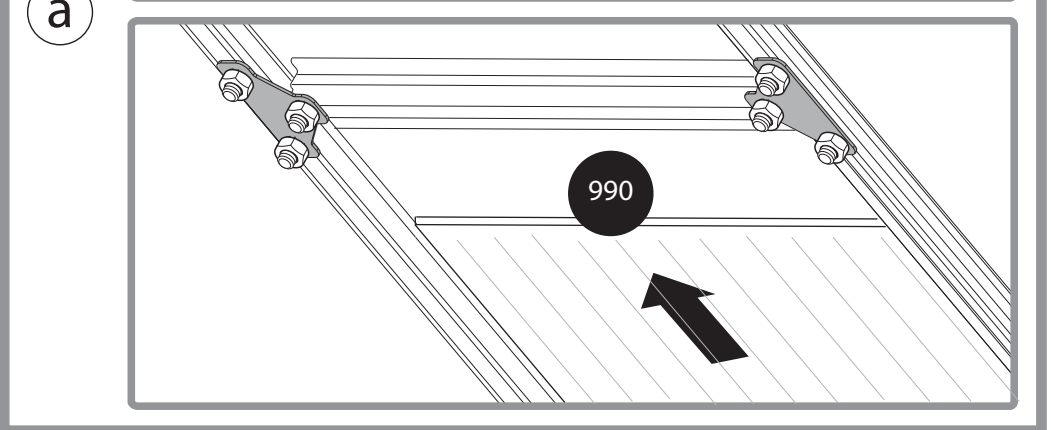
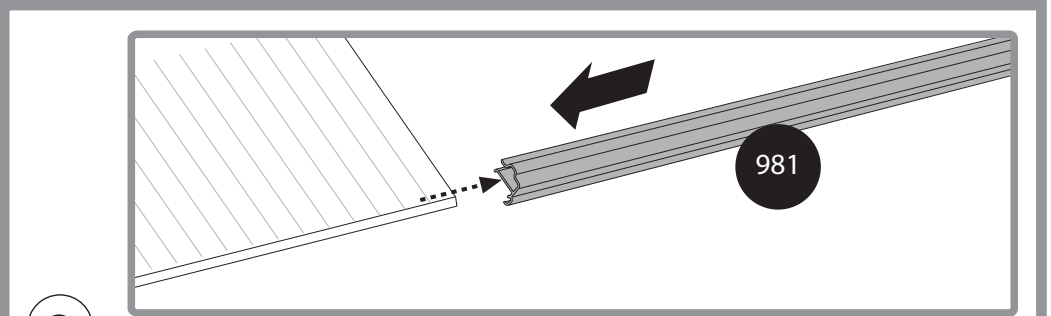
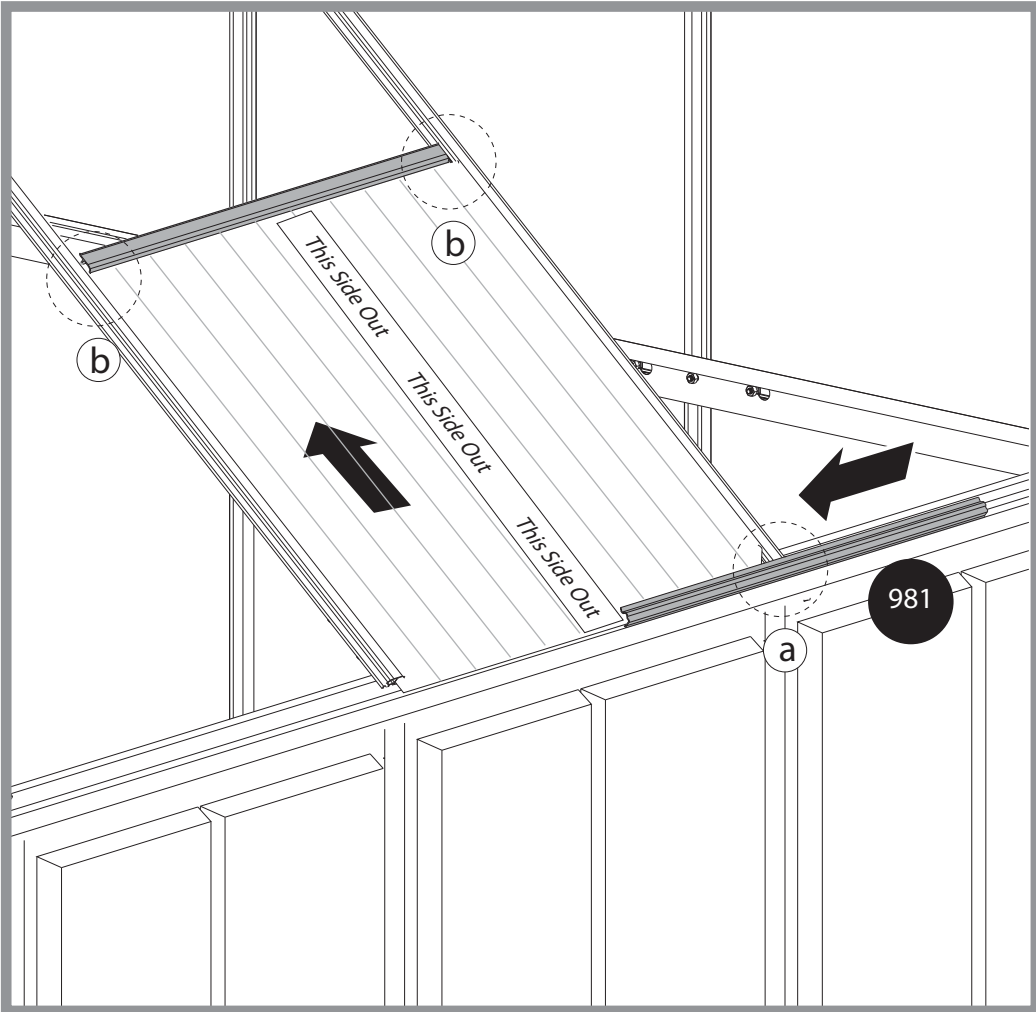
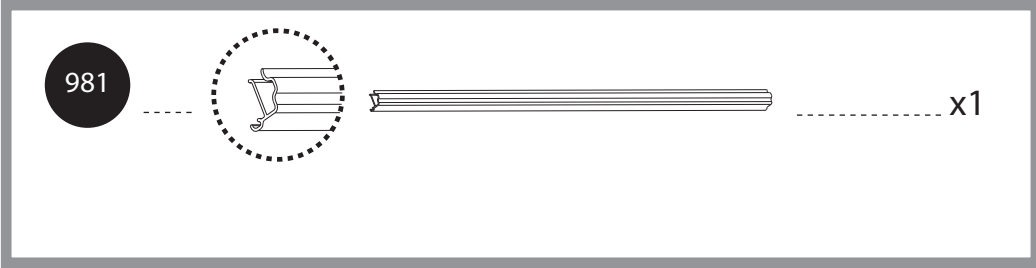
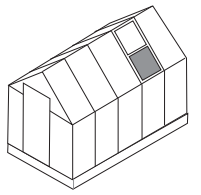

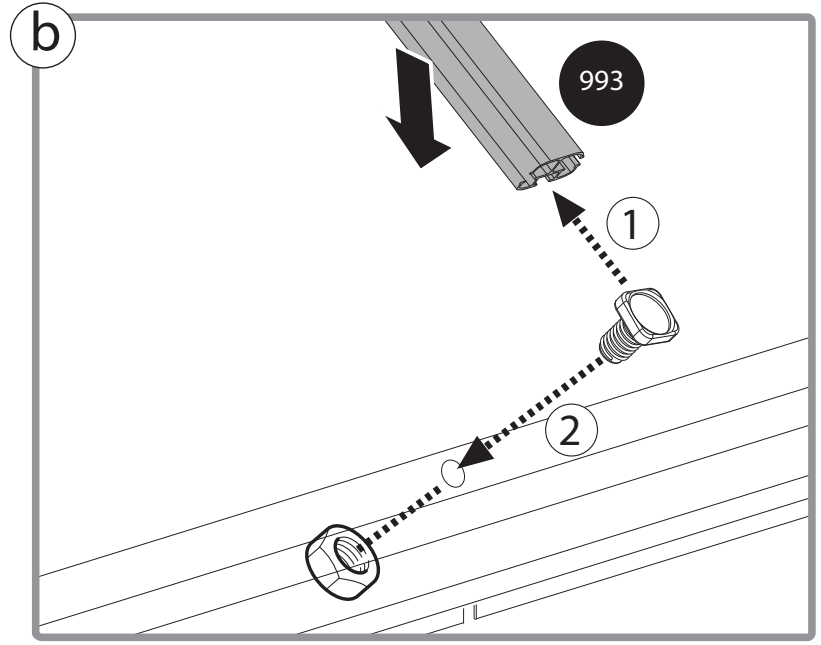
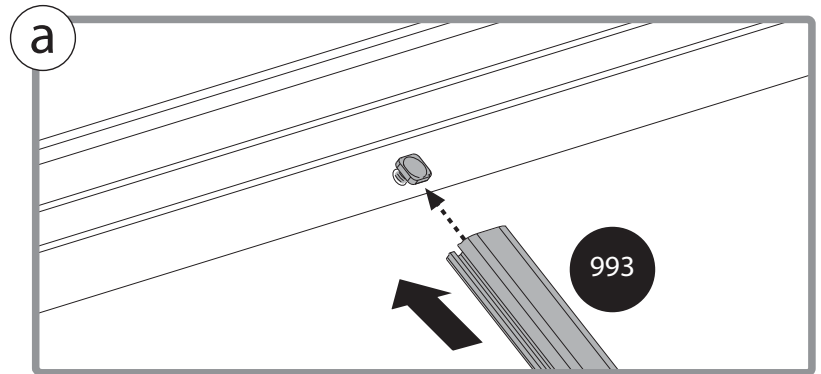
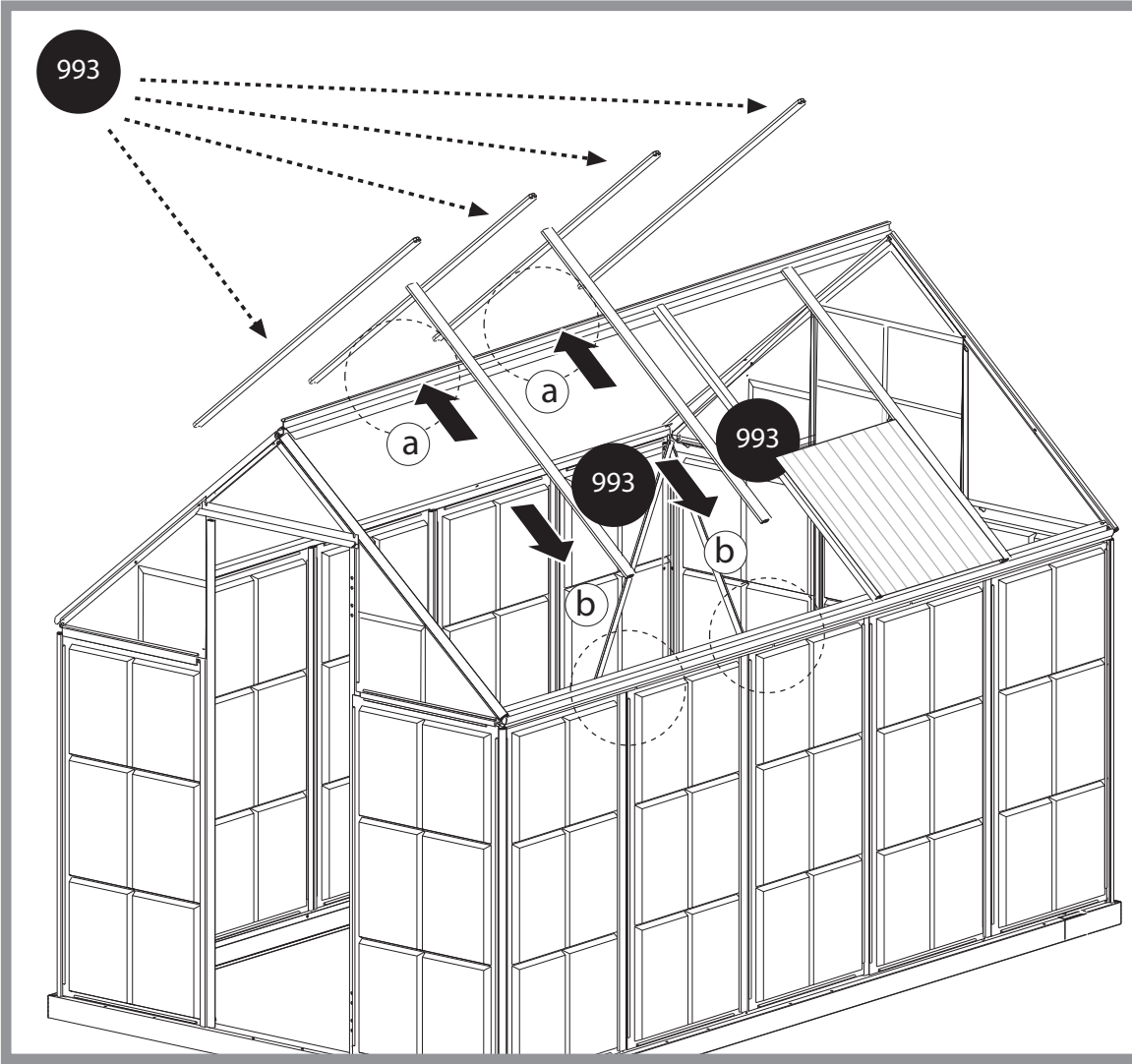
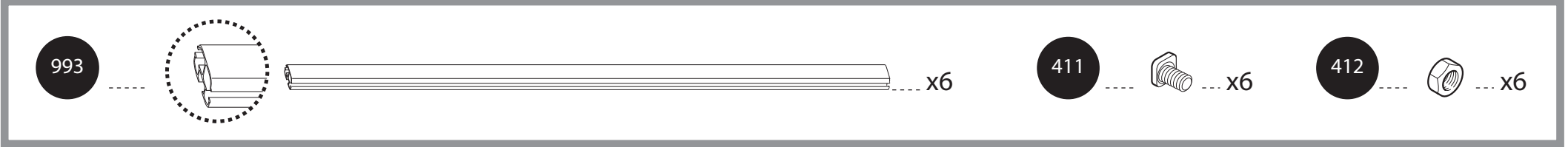
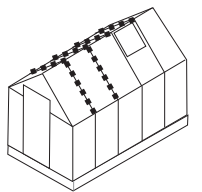

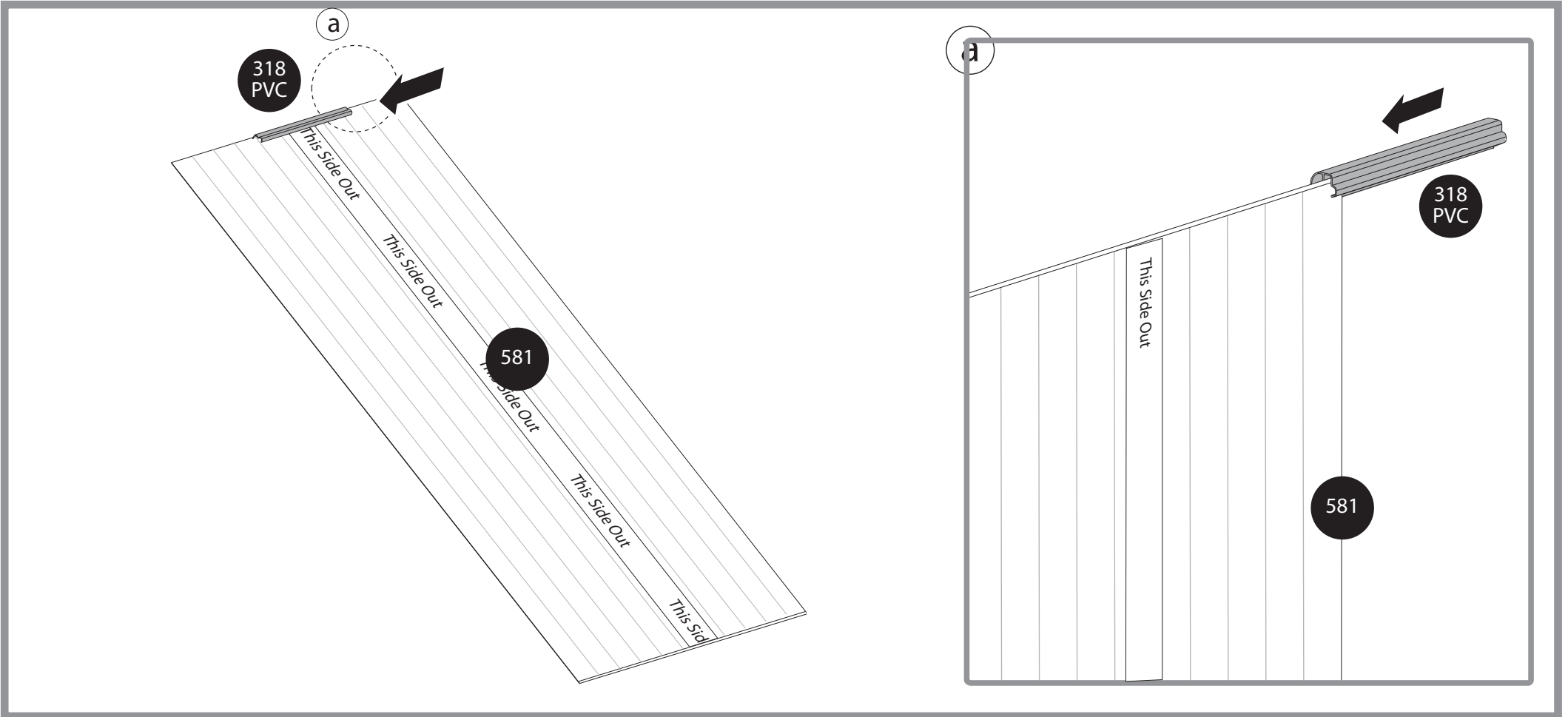
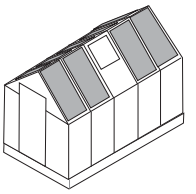

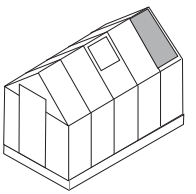

581



981

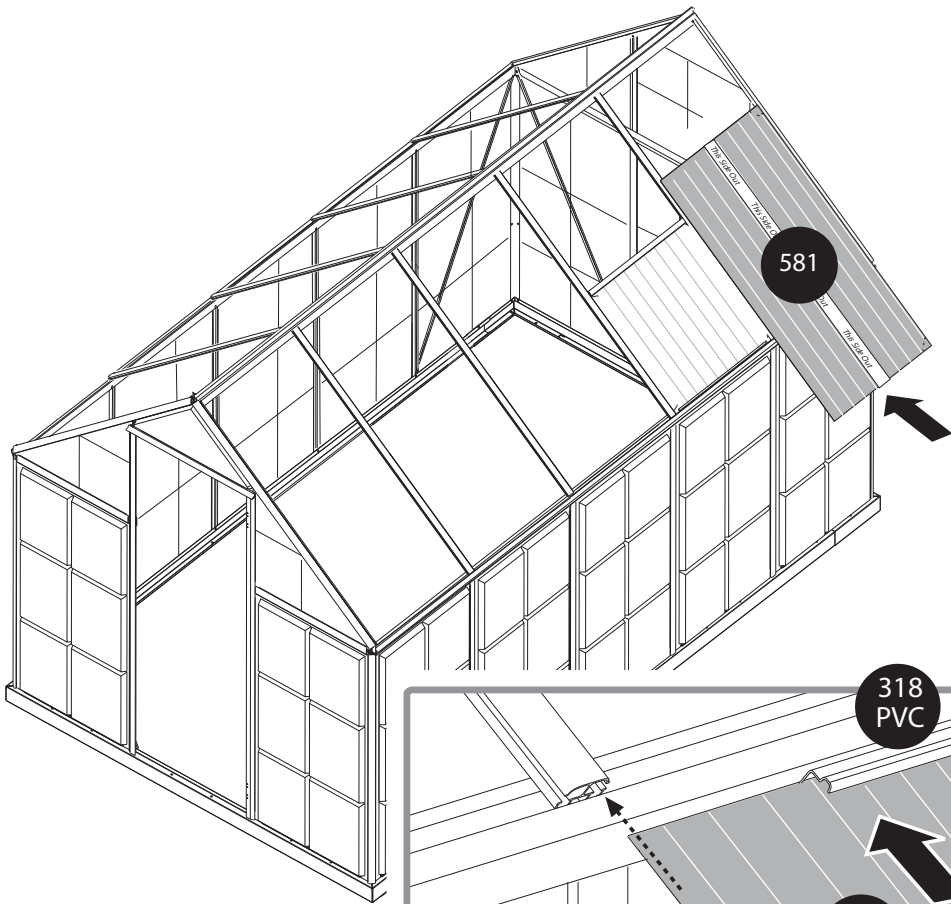
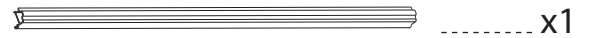
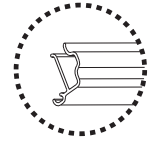

581

318
PVC

581

a

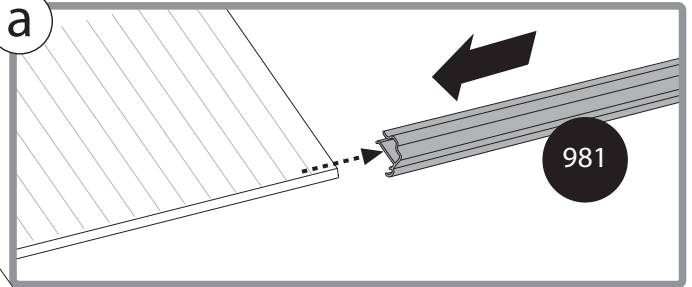

981

981

b

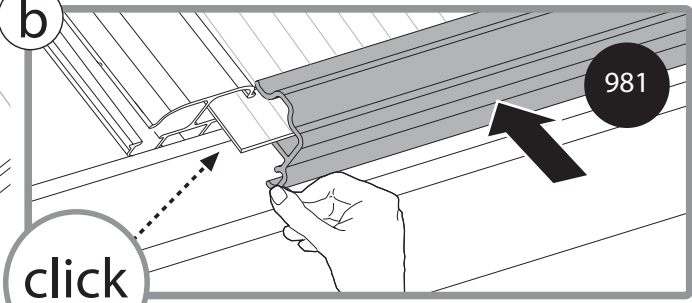

981

click

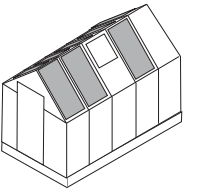

581

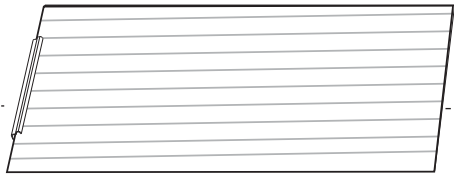

x8

981



x8

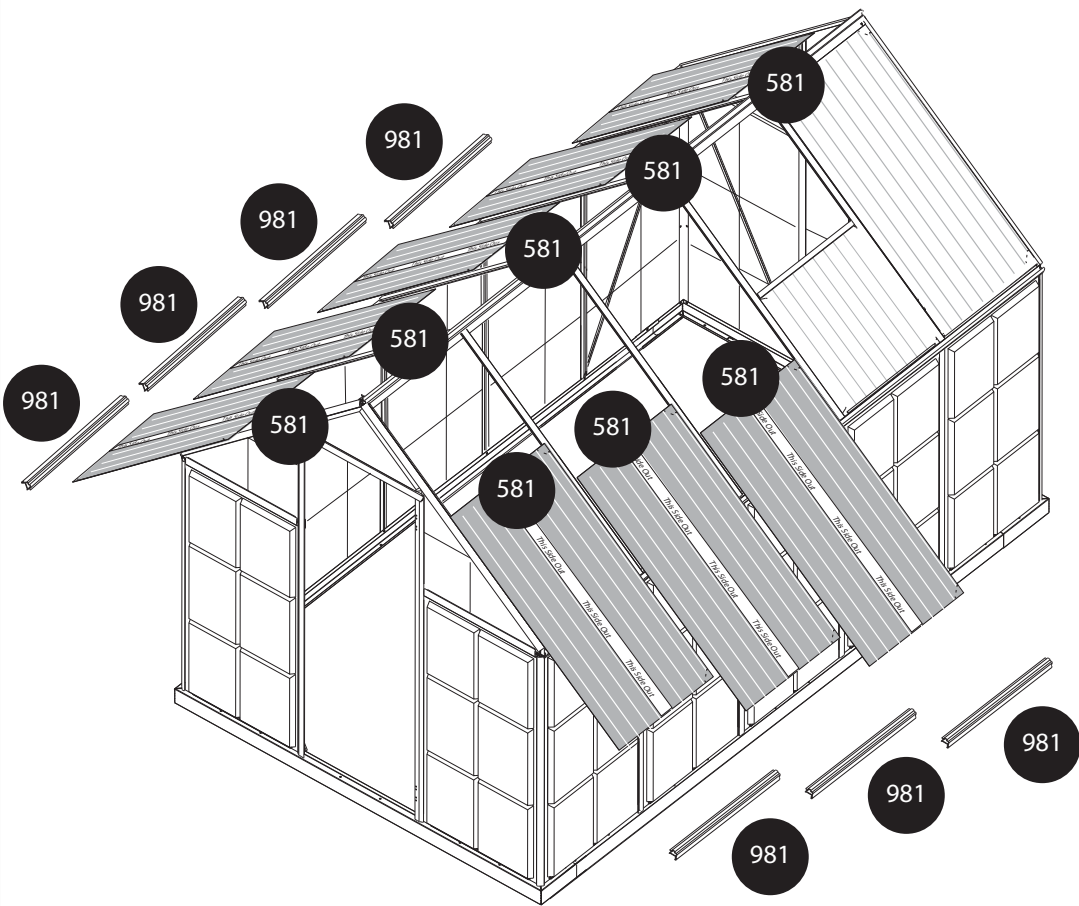

a

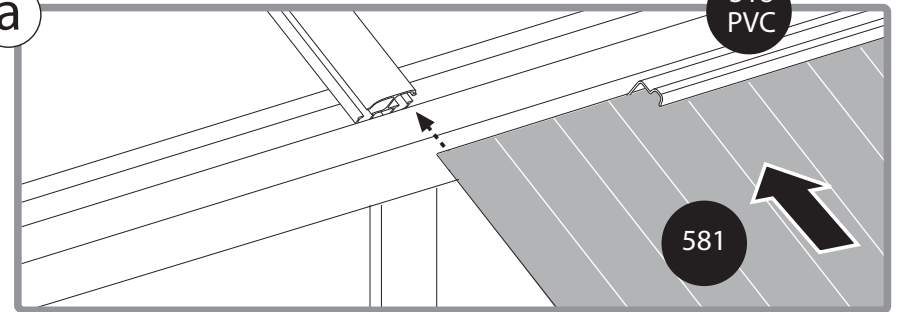

b

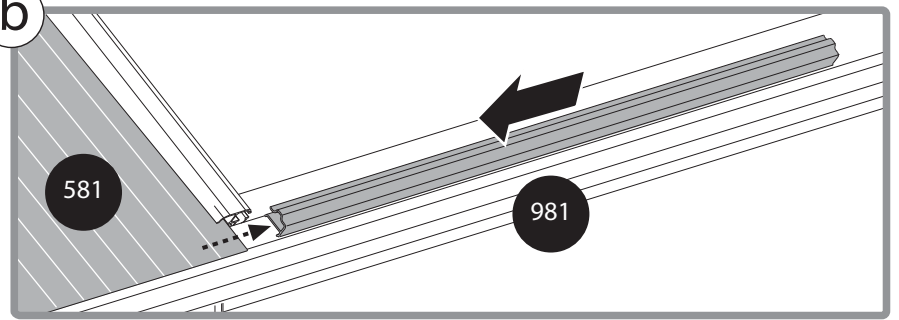

c

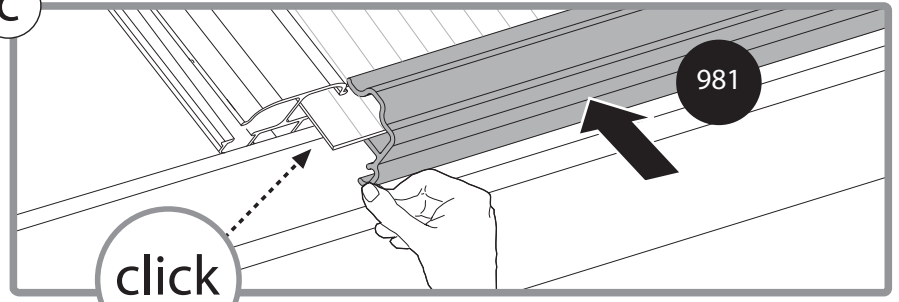

click

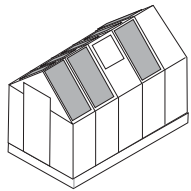

329

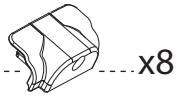

4043

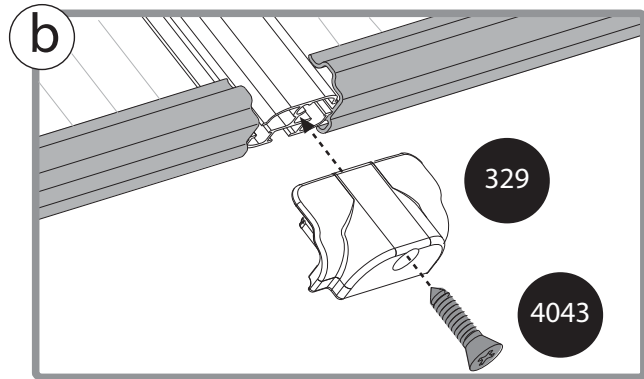
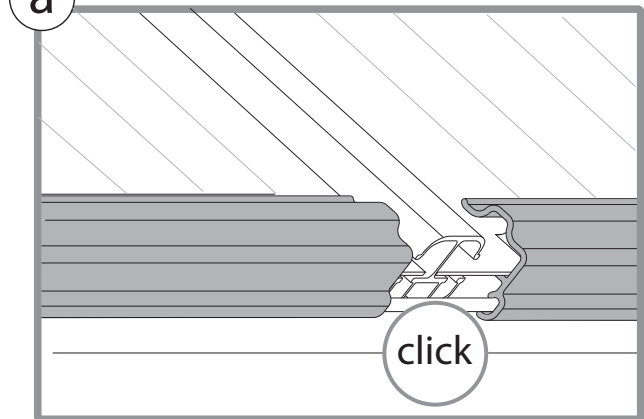
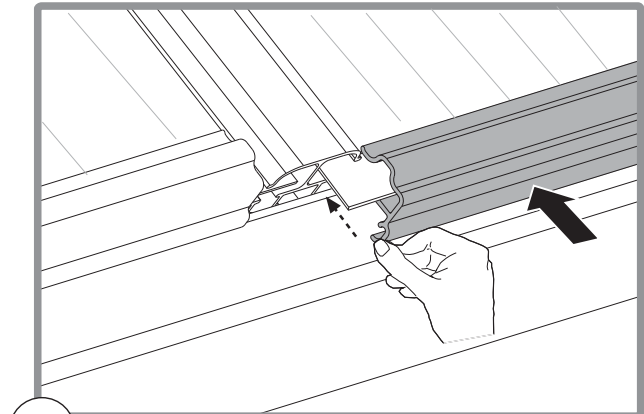
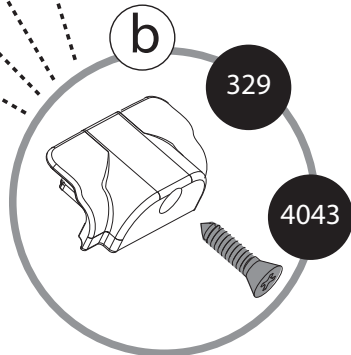
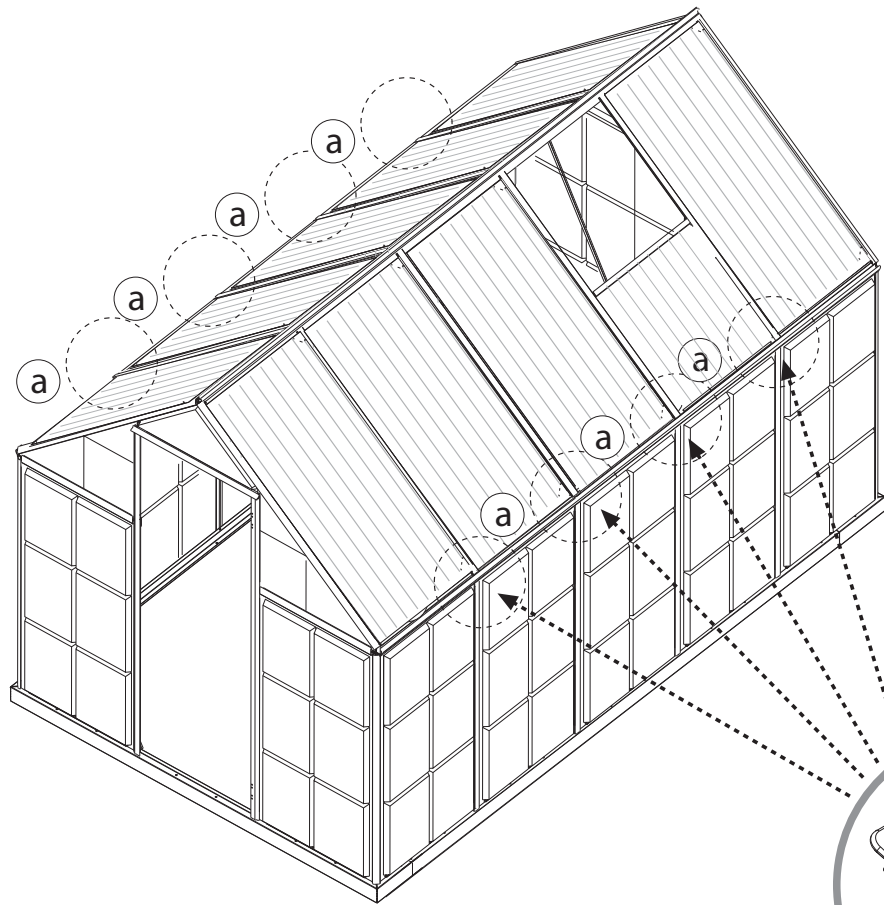

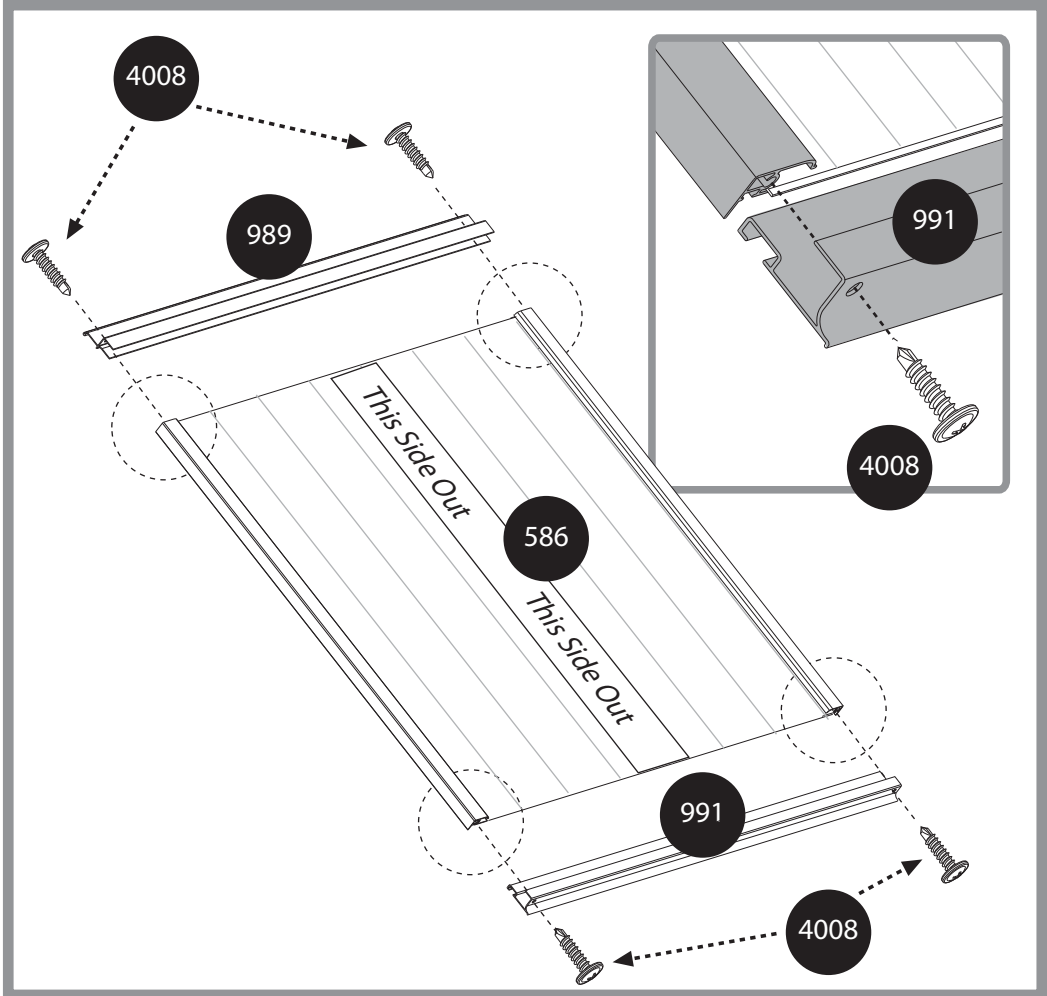
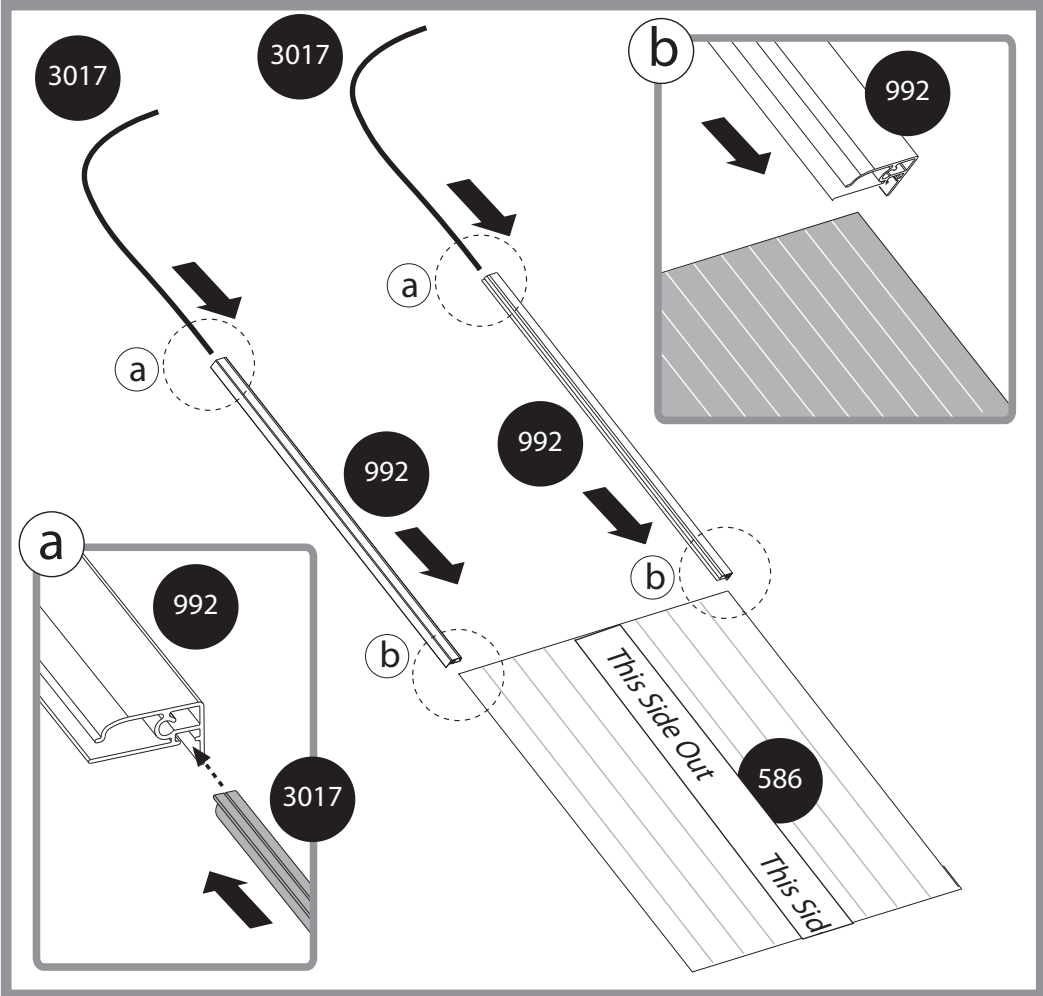
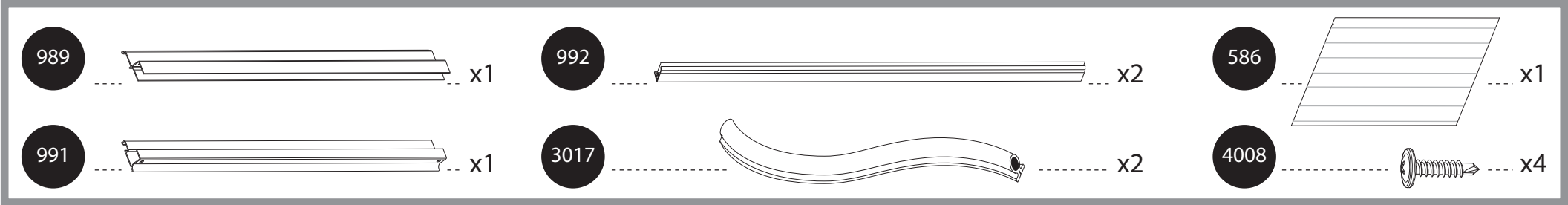
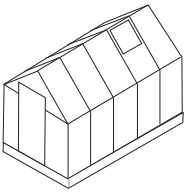

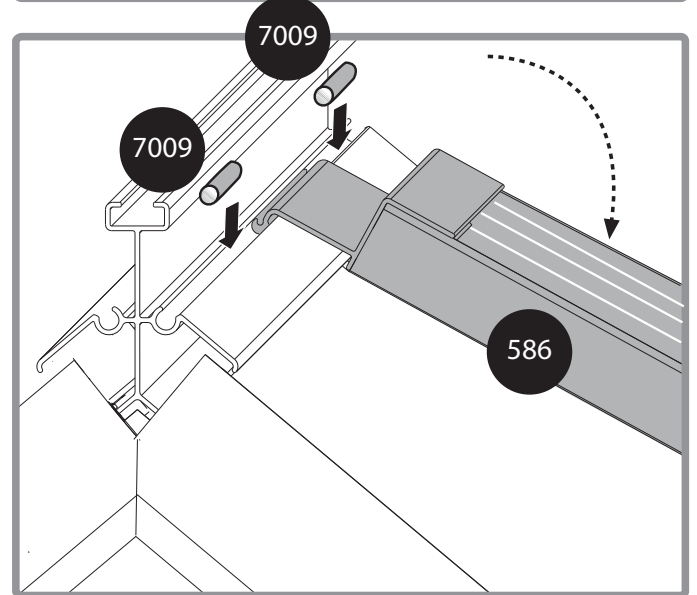
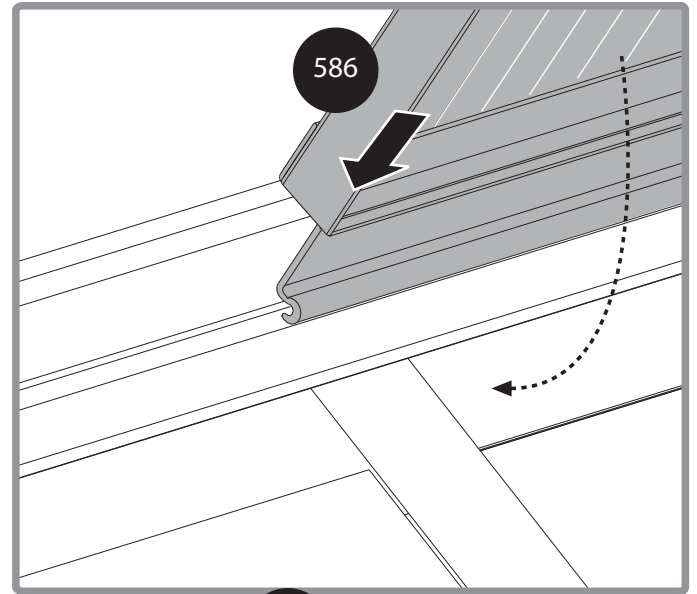
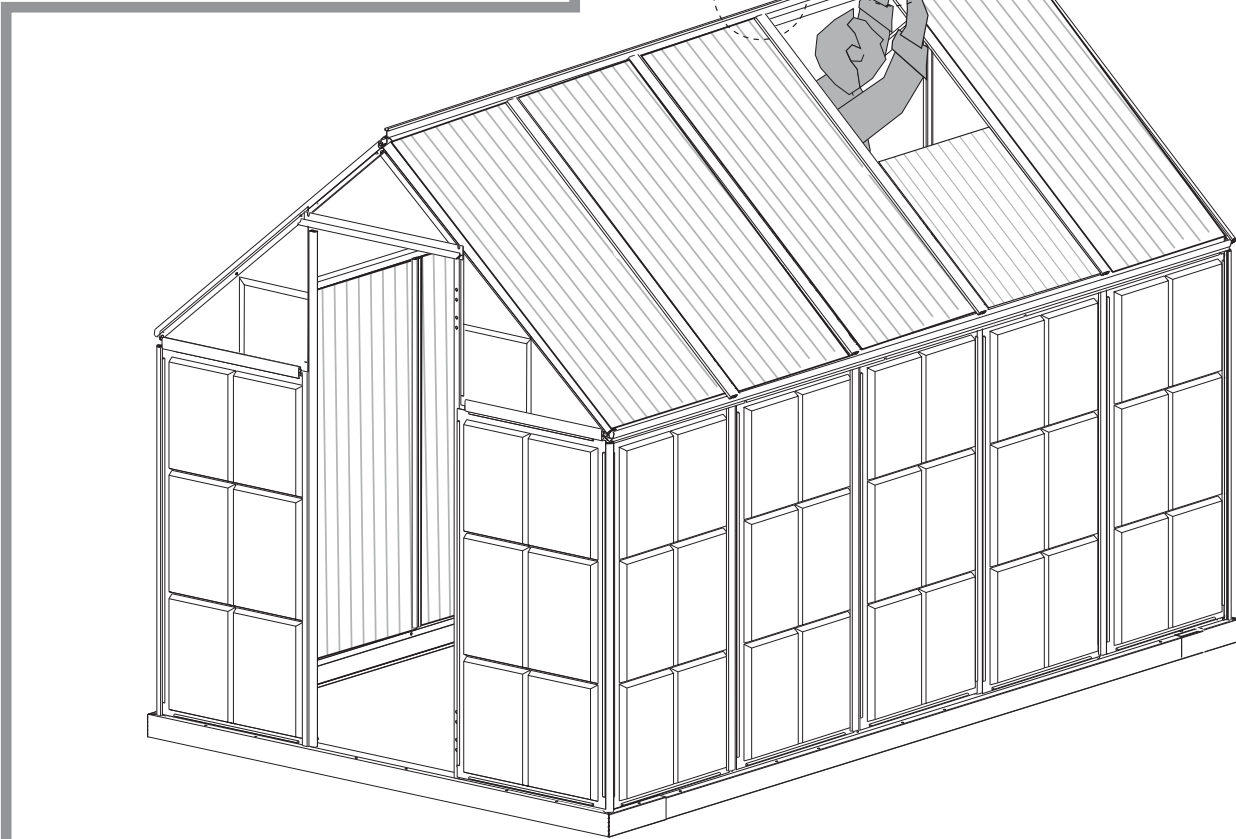
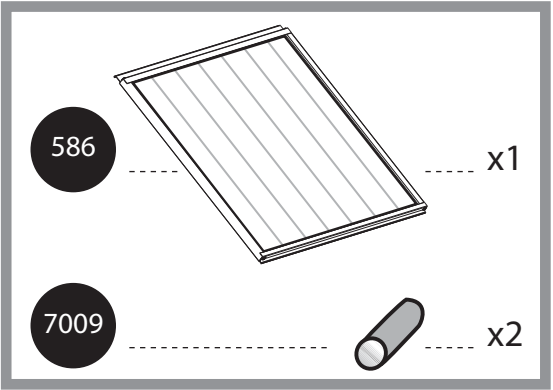
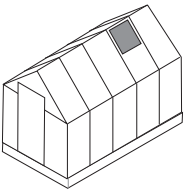

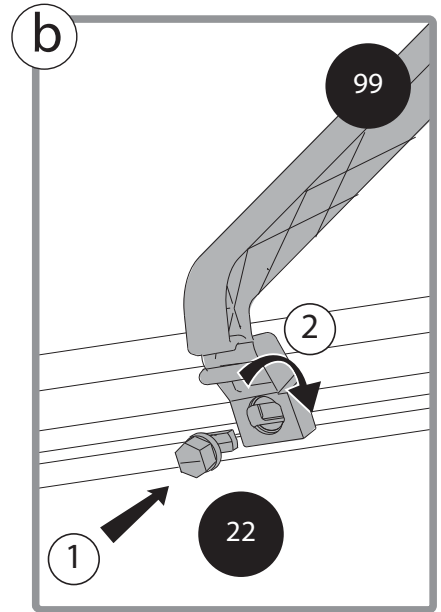
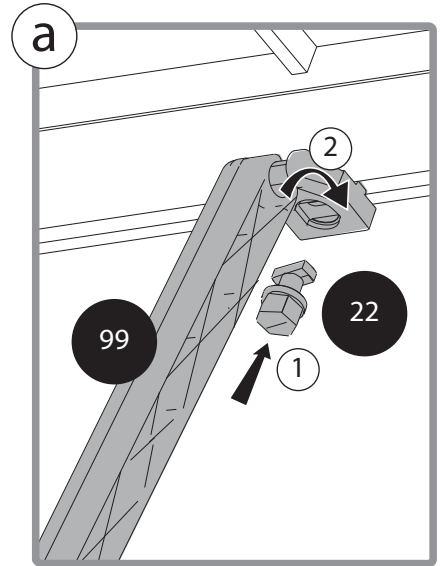
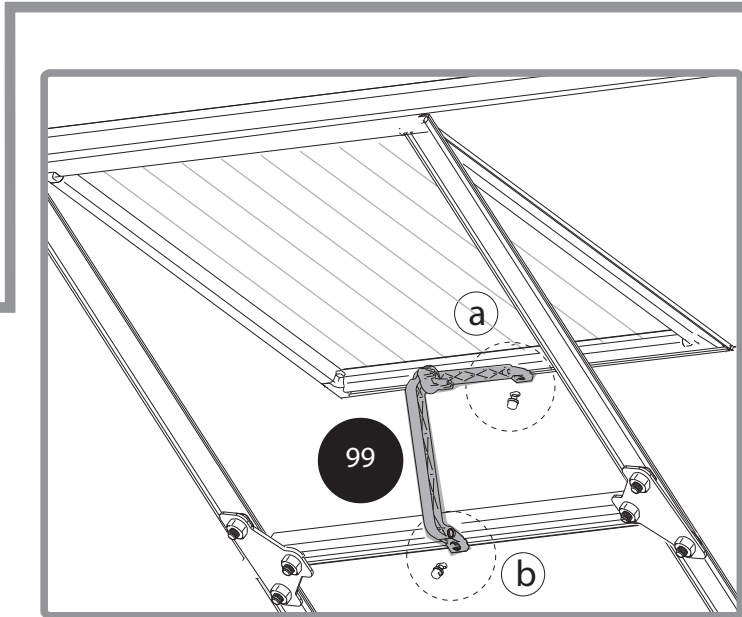
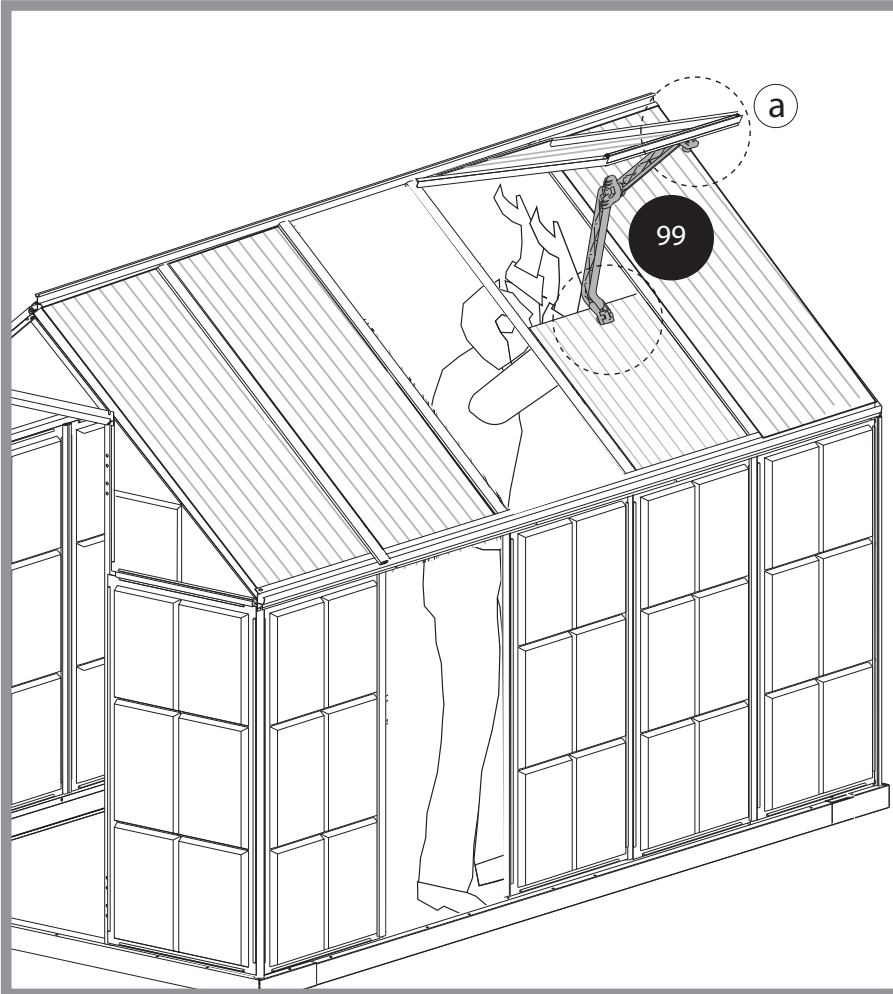
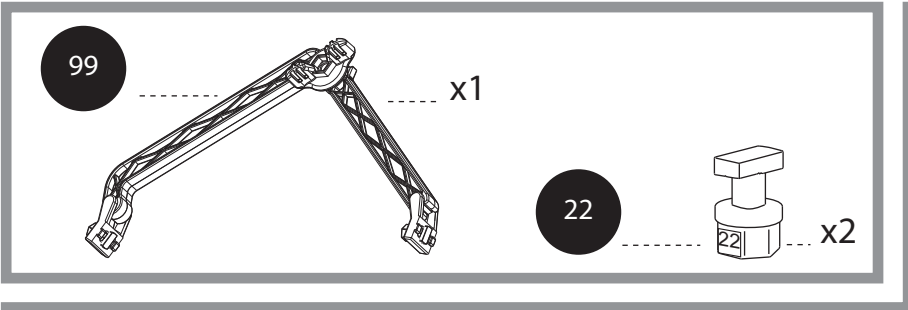
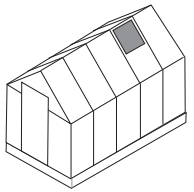

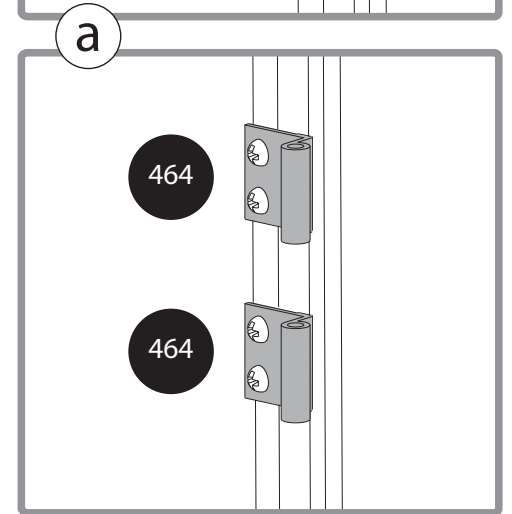
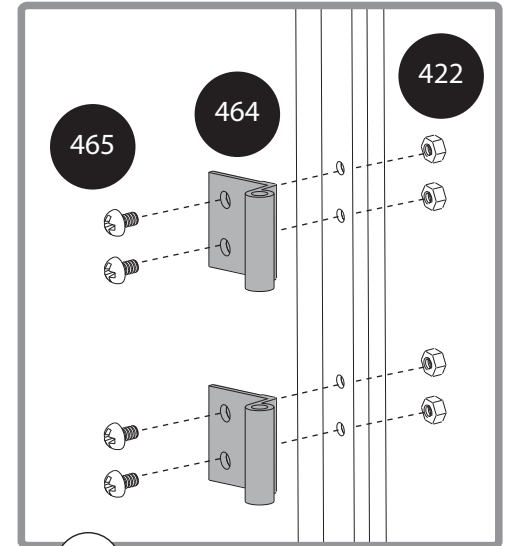
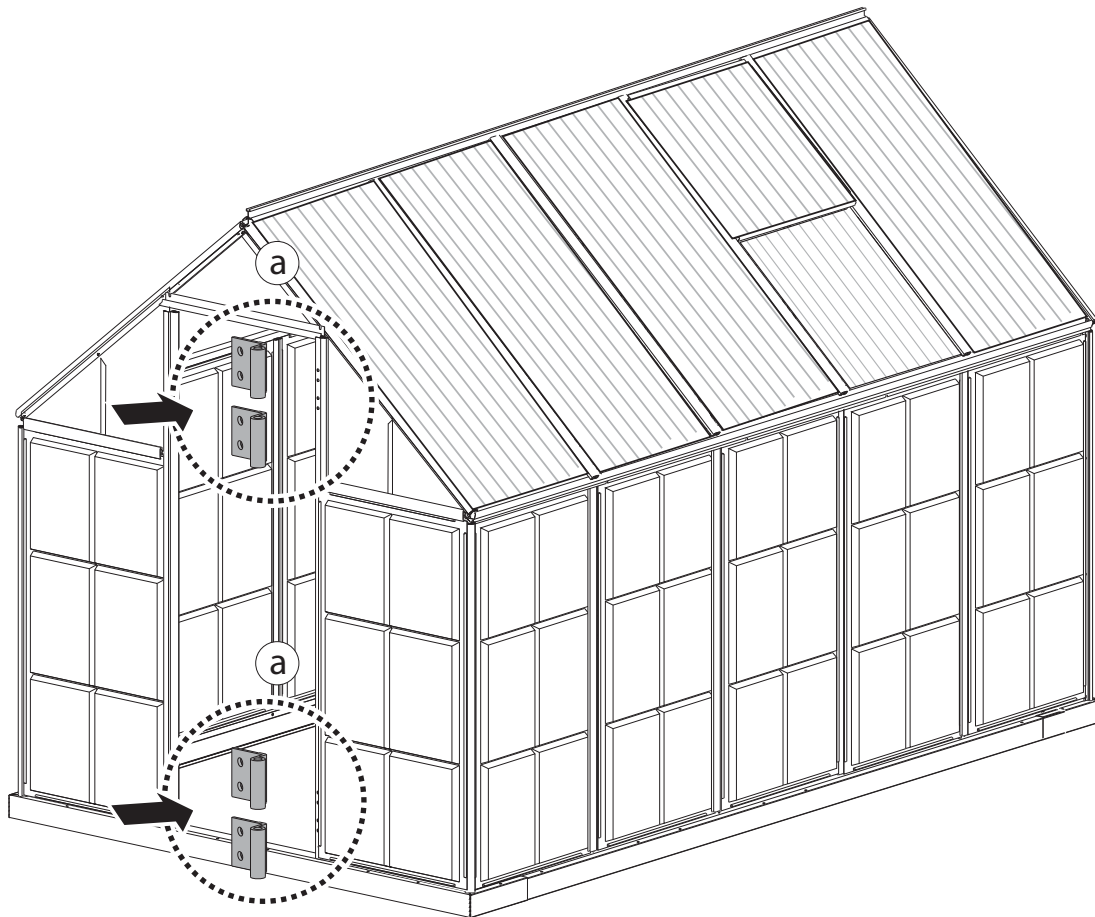
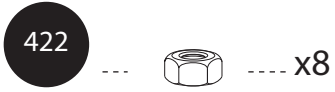
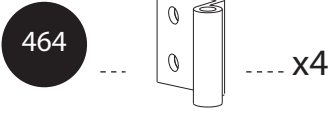
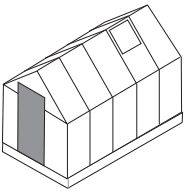

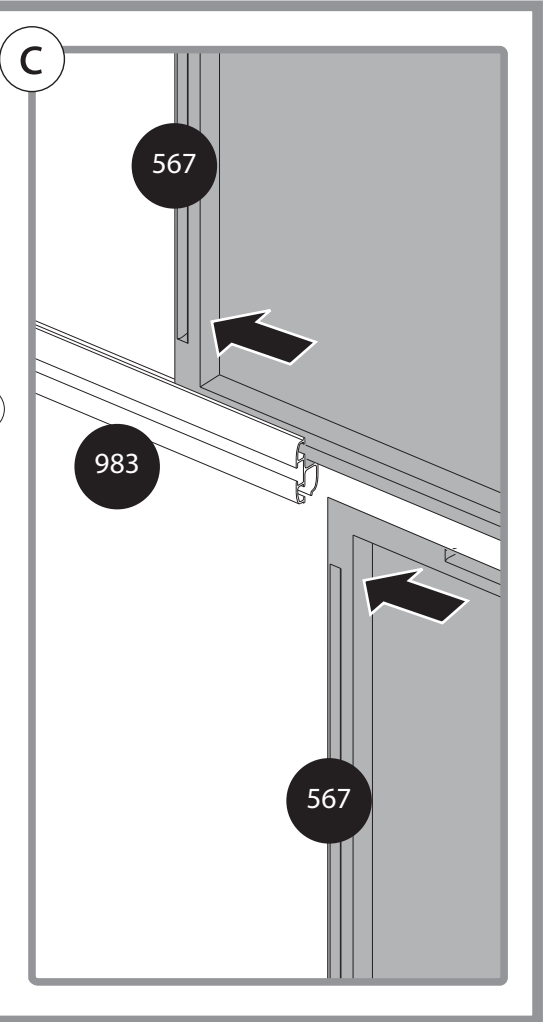
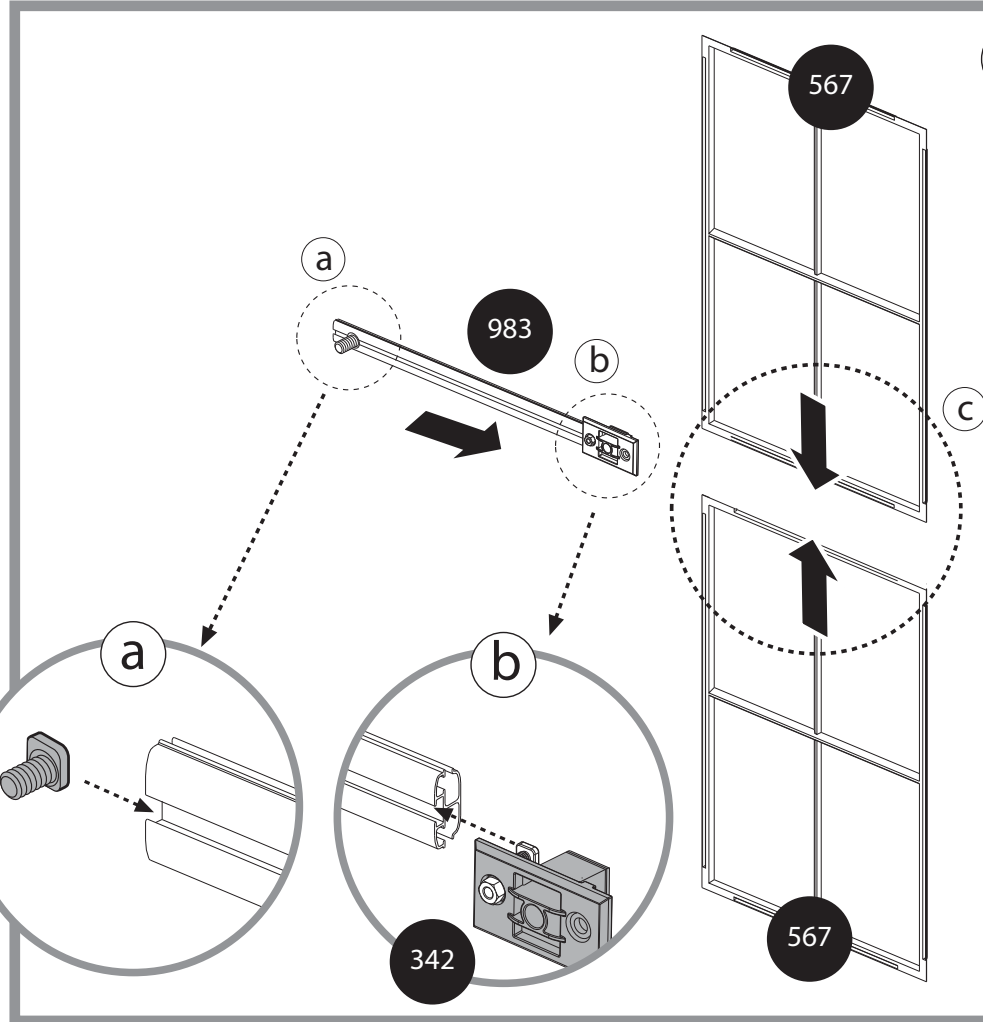
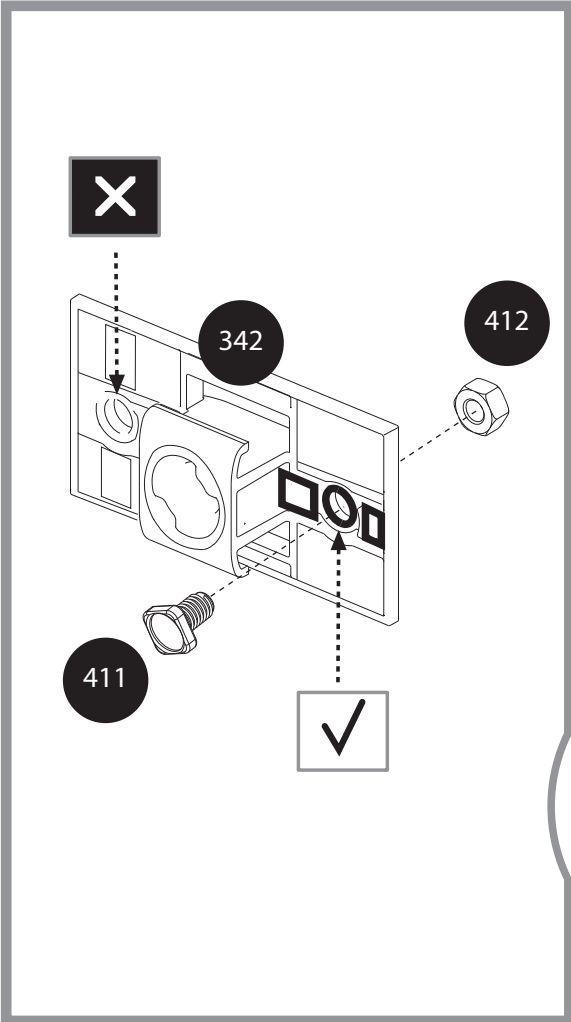
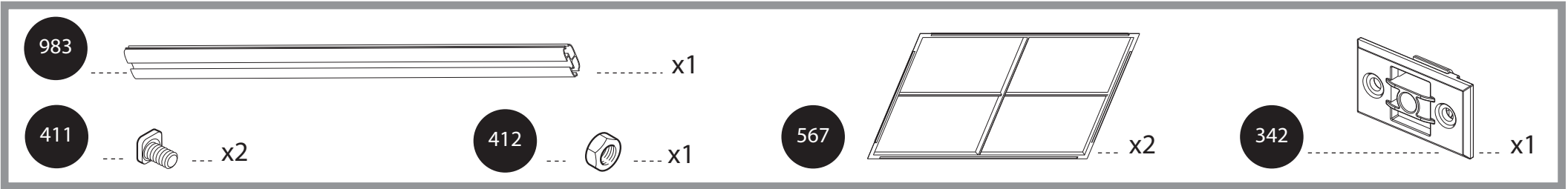
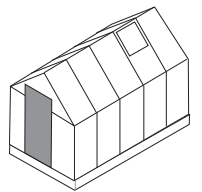

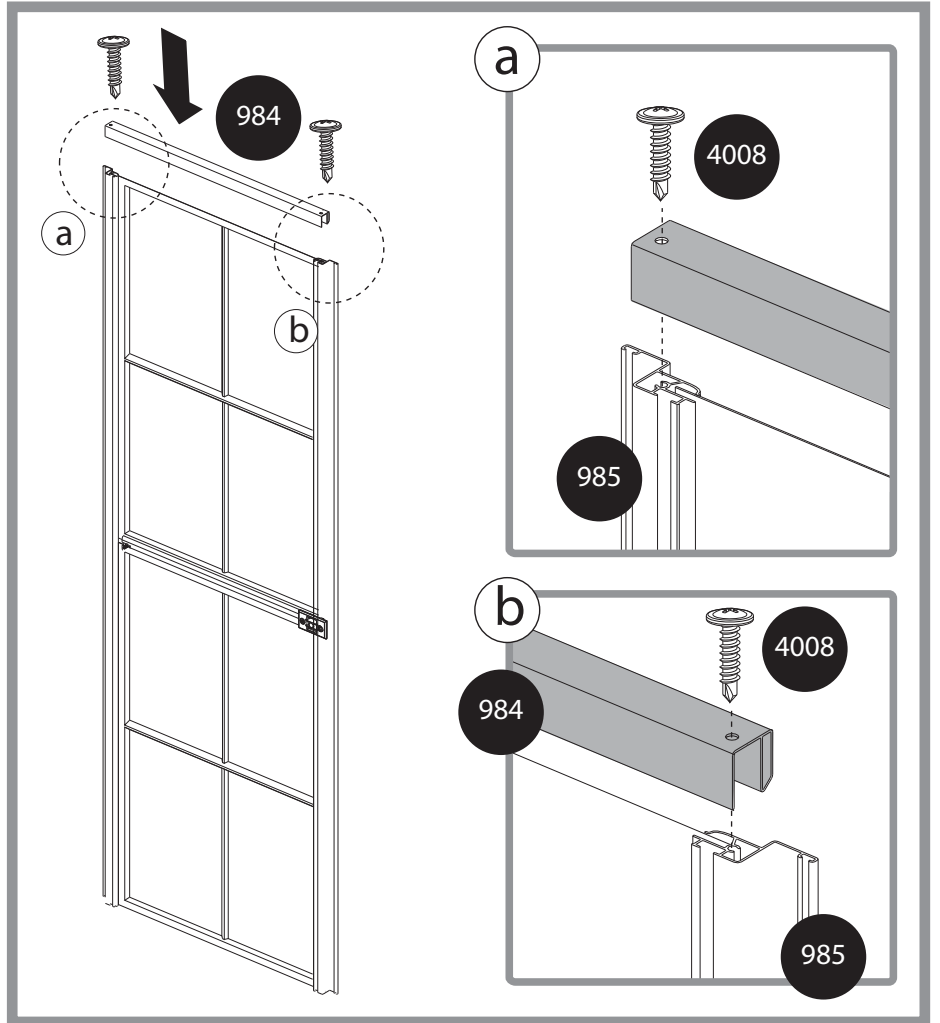
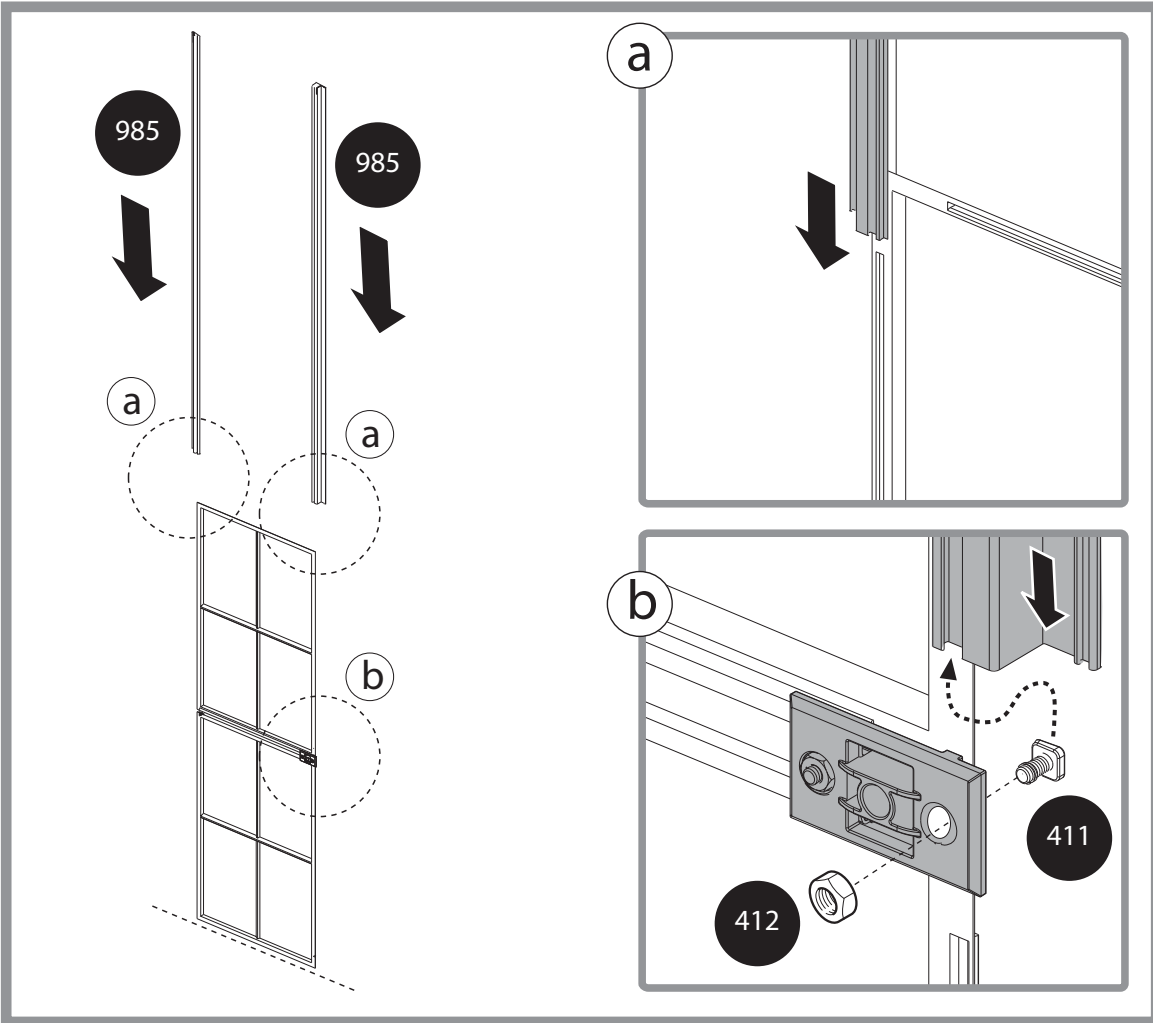
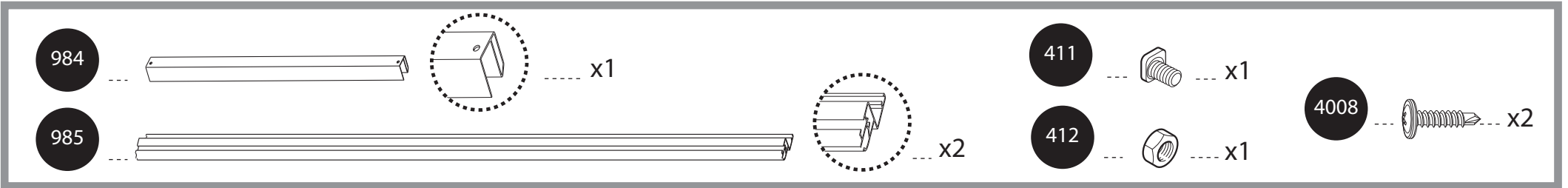
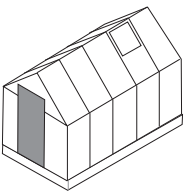

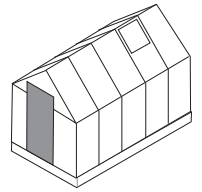

3016 x1

288 x1

412 x7

462 x2

411 x6

a

b

411 x6

3016

a

b

x6

412

462

288

412

412

462

288

462

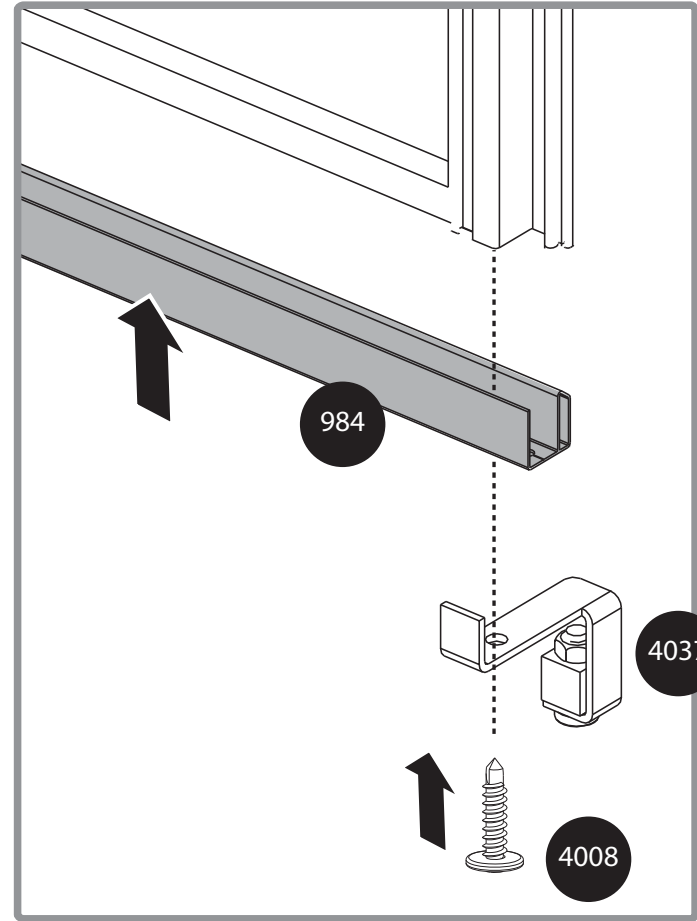
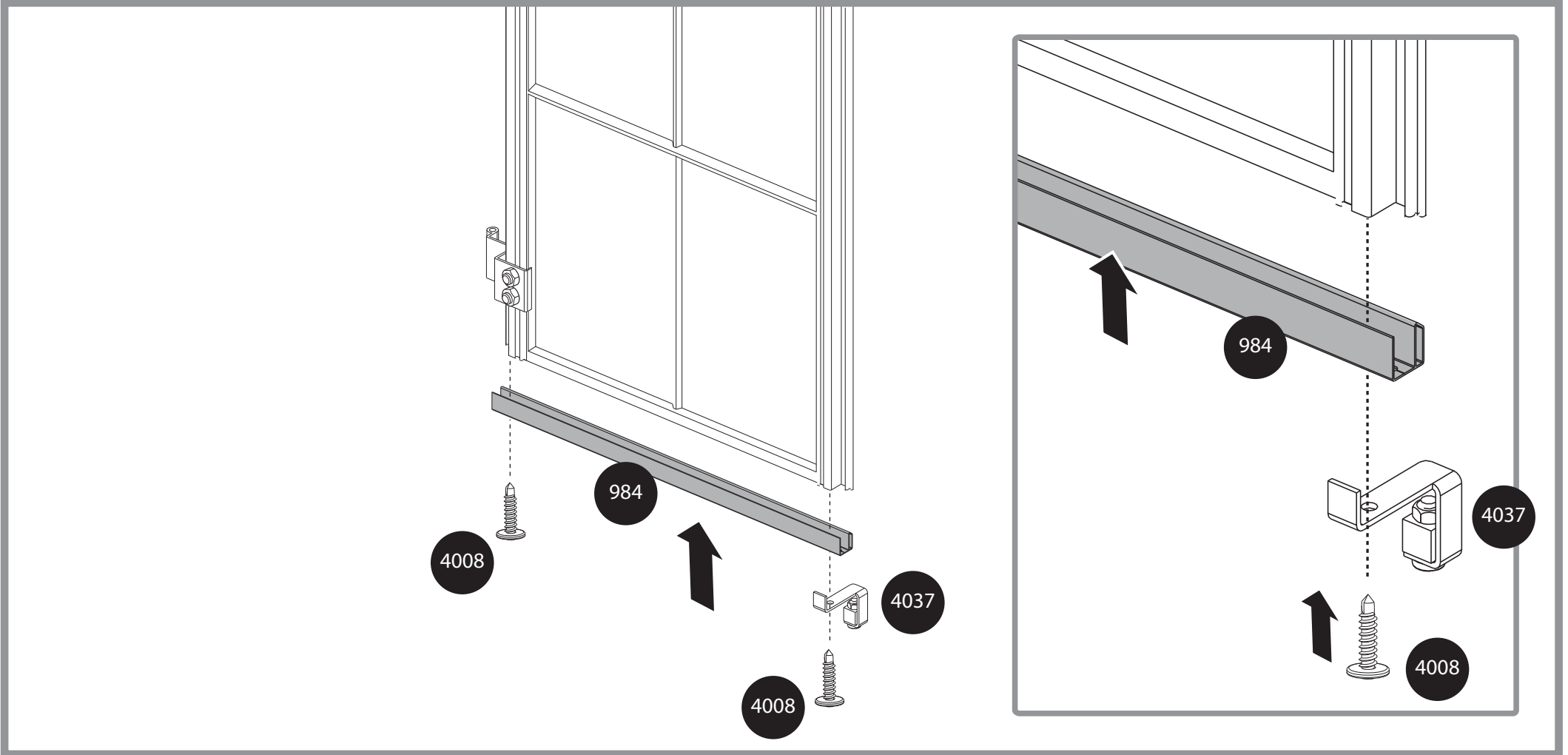
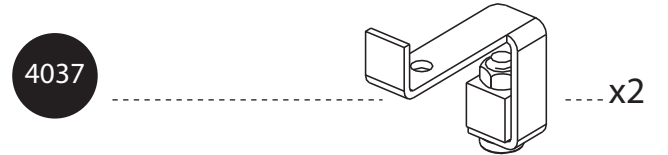
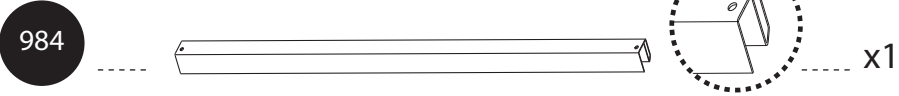
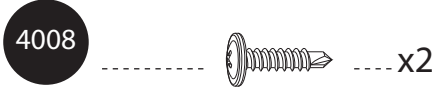
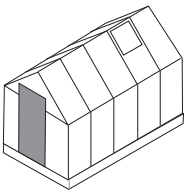

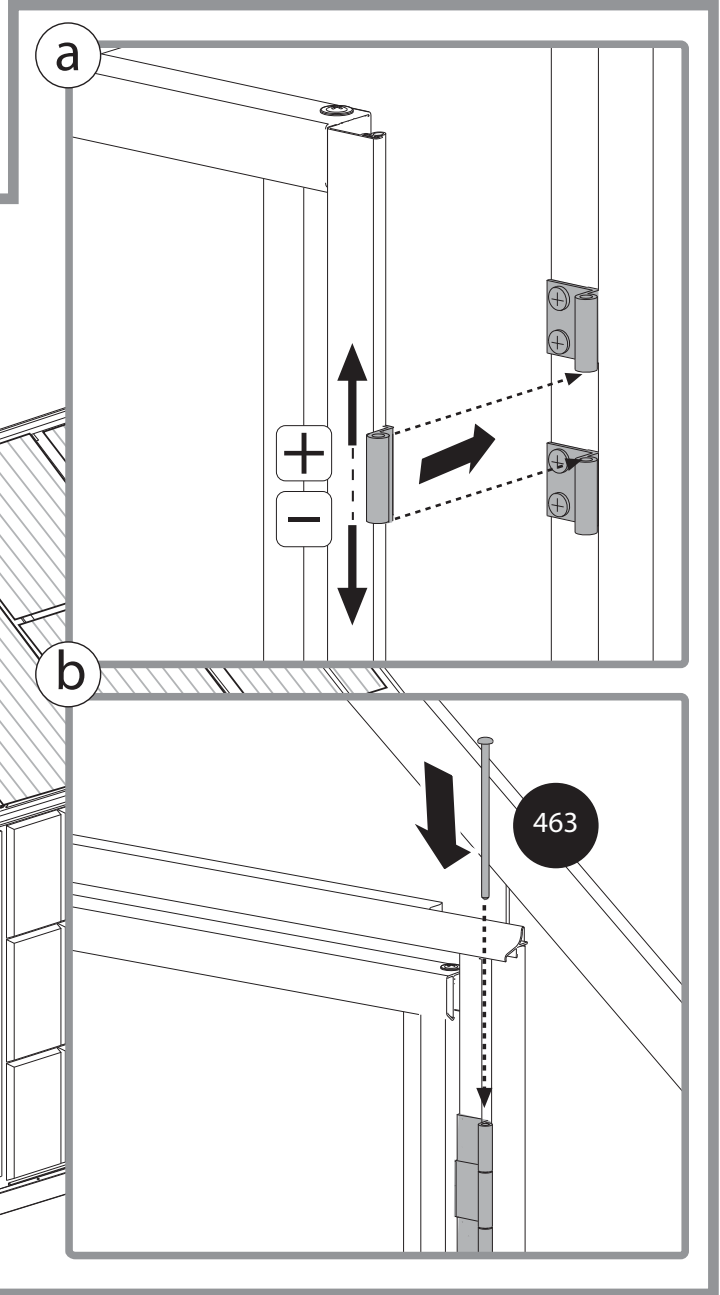
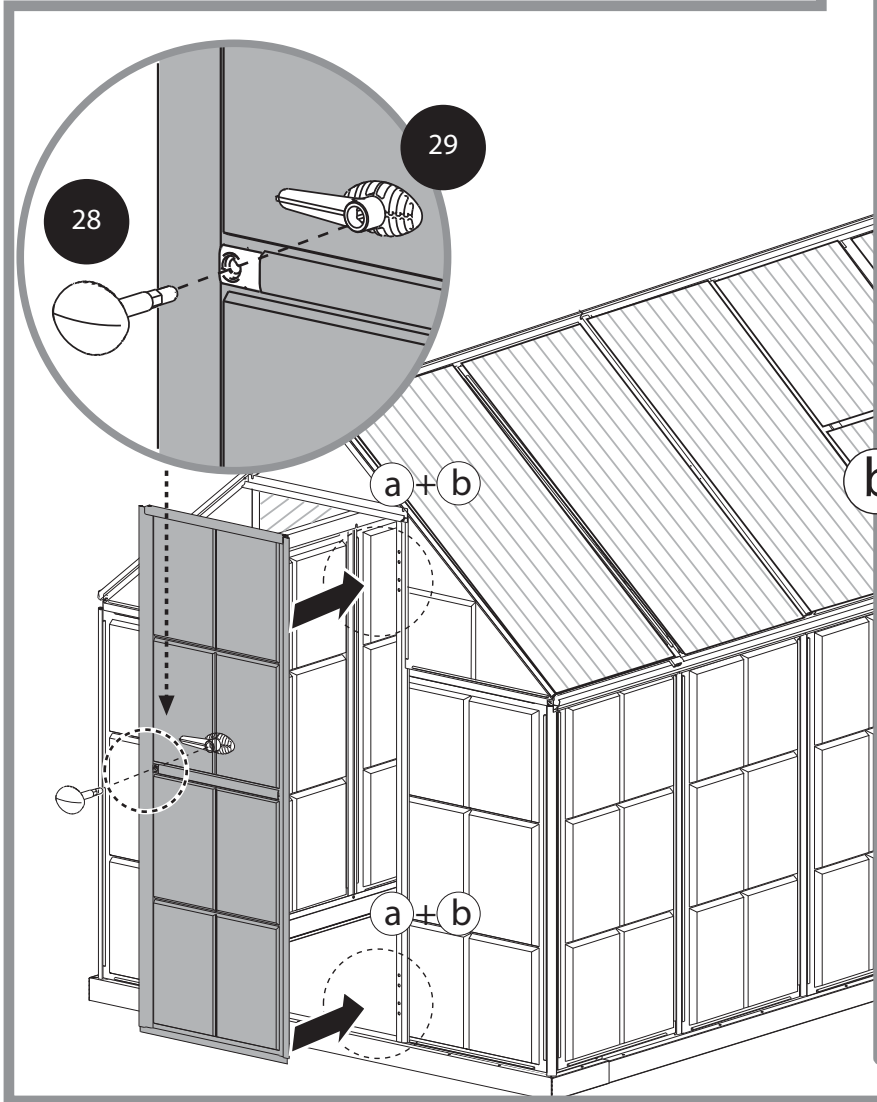
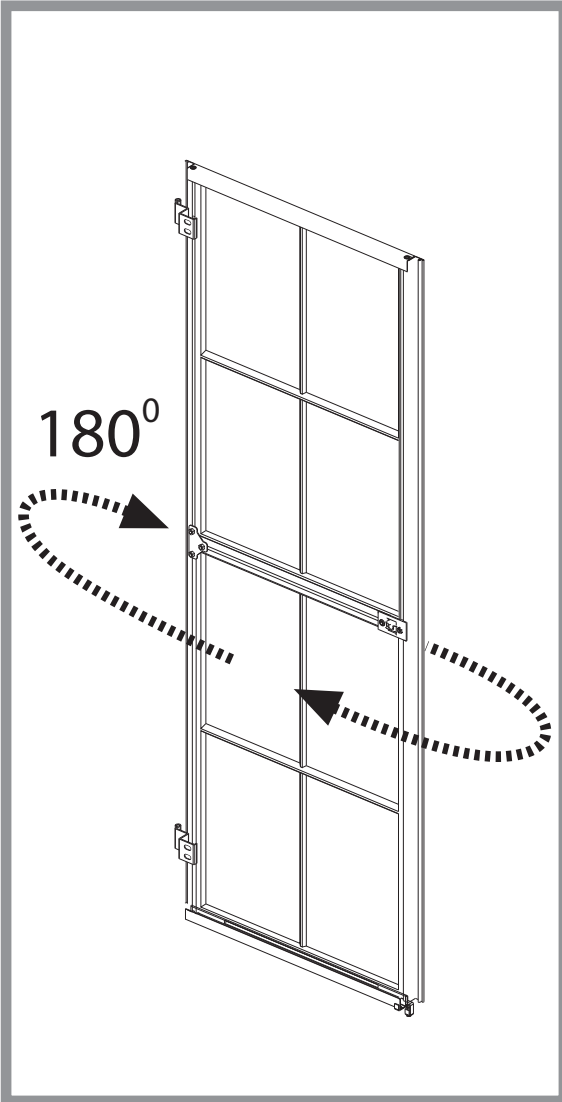
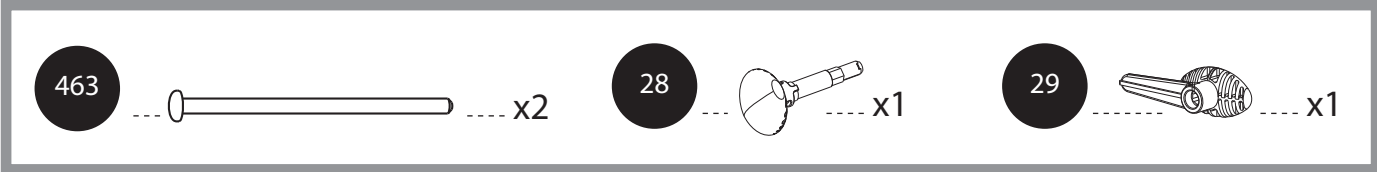
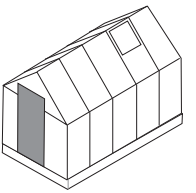

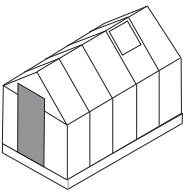

344L x2 344R x2 343 x2 447 x4

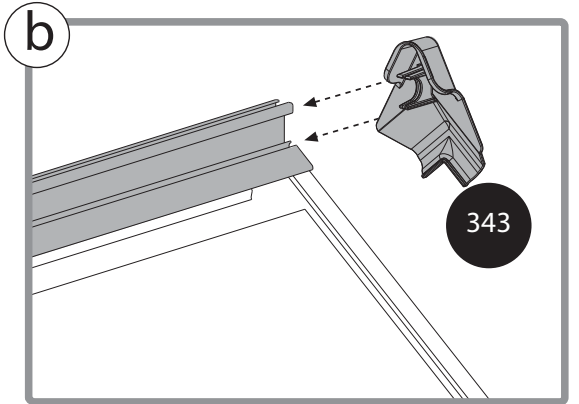
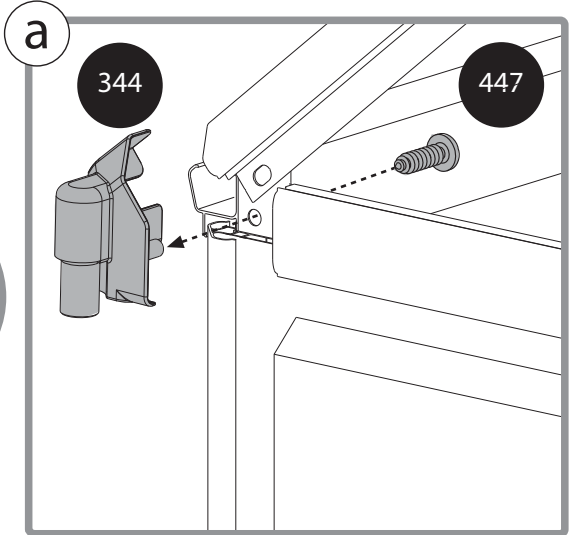
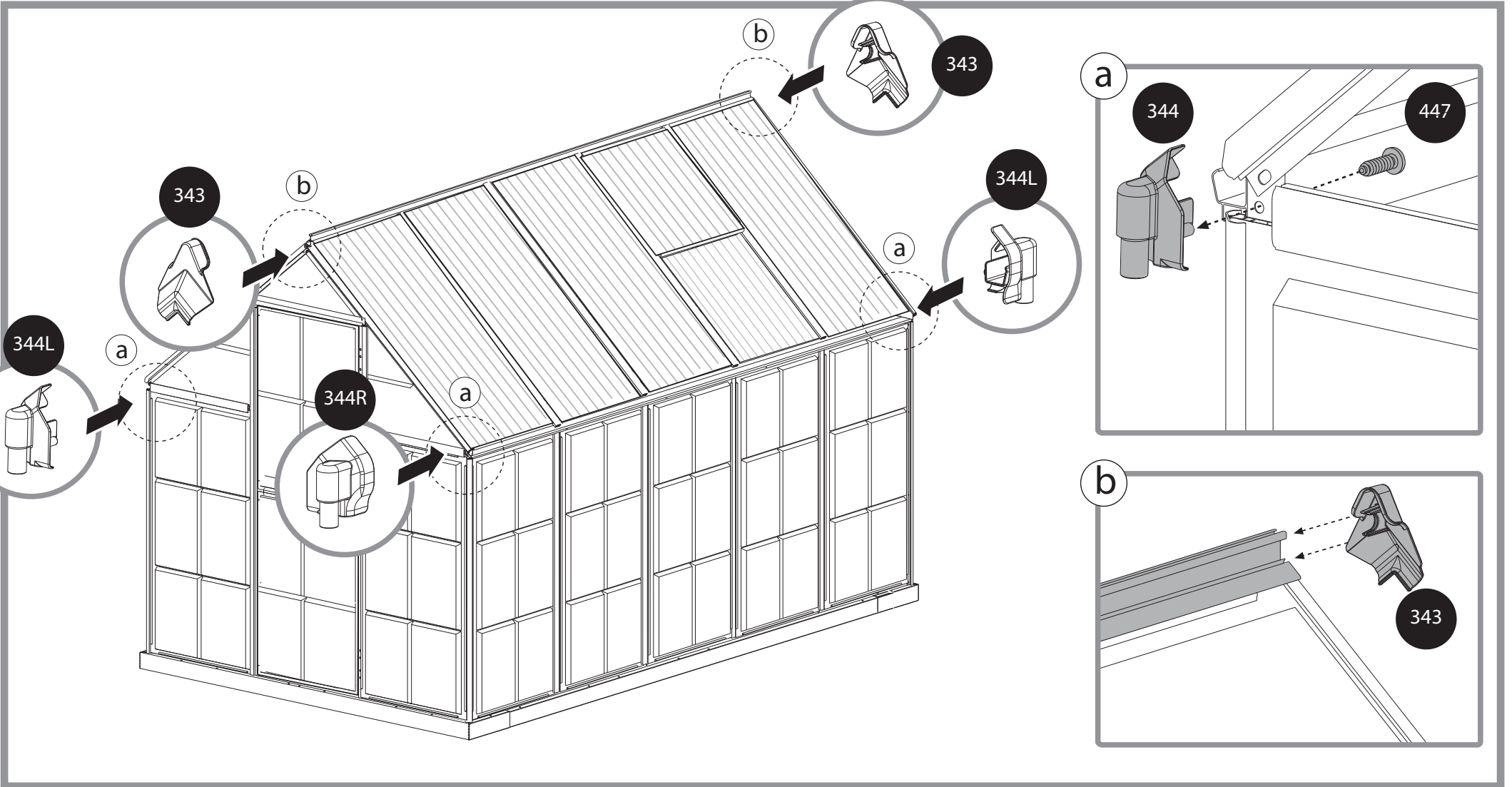

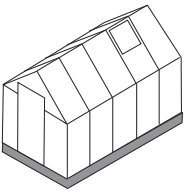

M96

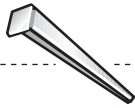

x4

P328

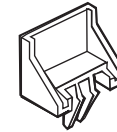

x30

